

SYNCHRON

MACHINE TOOLS PVT. LTD.

AN ISO 9001-2008 Certified Company

NO.48/D 4TH N BLOCK, 3RD STAGE RAJAJINAGAR, BANGALORE -560 010

PH: 080-23123655 FAX:080-23126713

Email: synchron.tools@gmail.com/synchron.tools@outlook.com

Web Site: synchronmachinetools.com

Classic frame welding station

ROYAL
ENFIELD

SMT

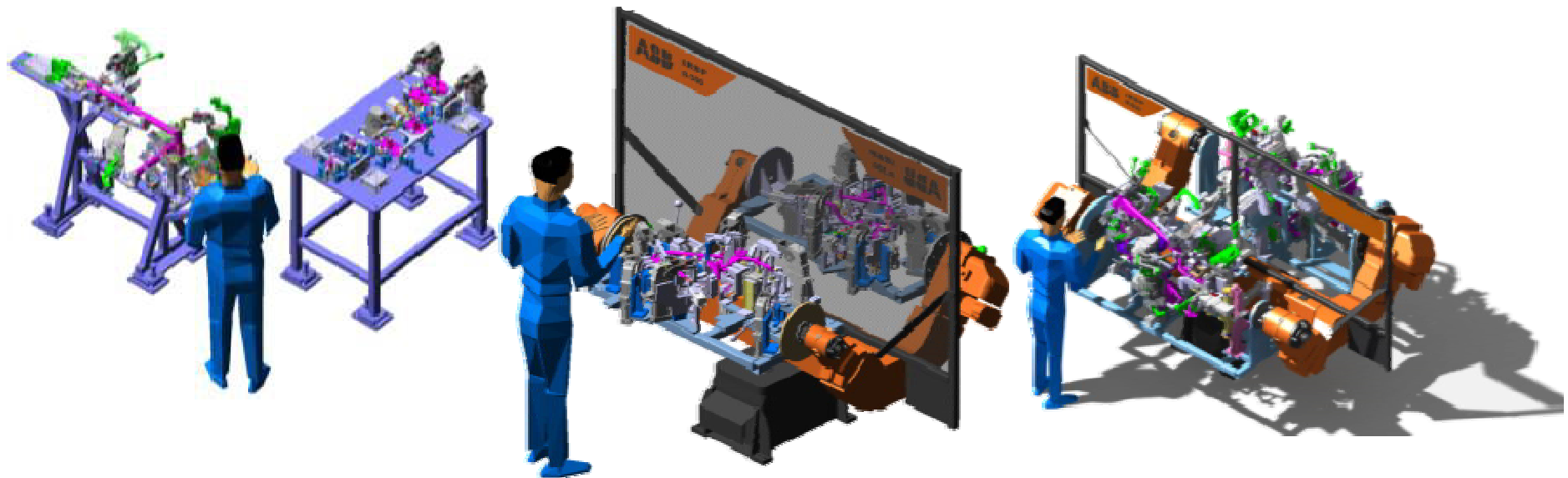
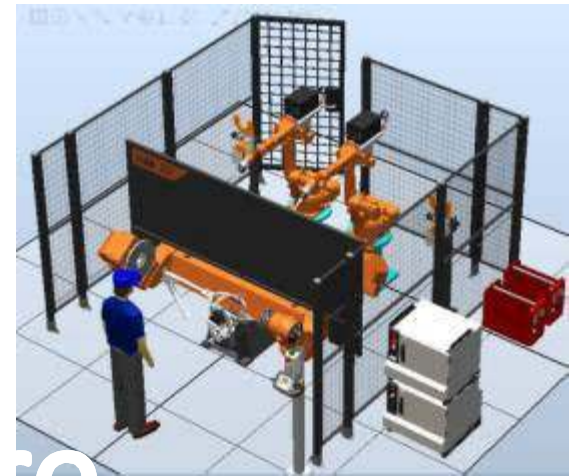
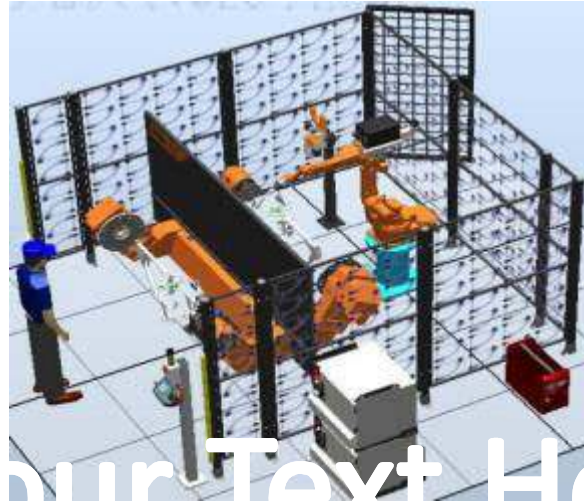
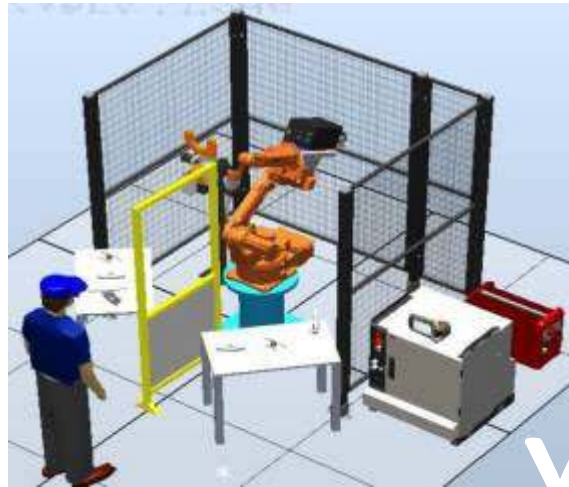

Body side & Roof welding



SMT

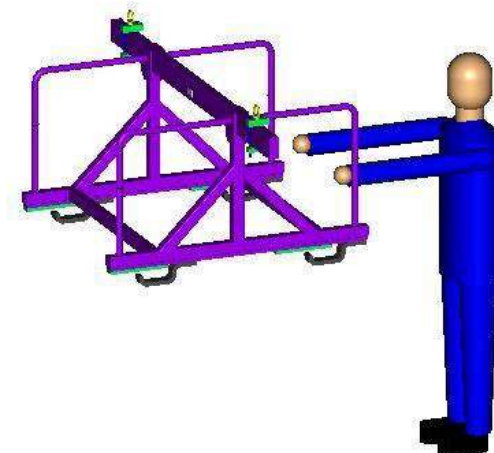
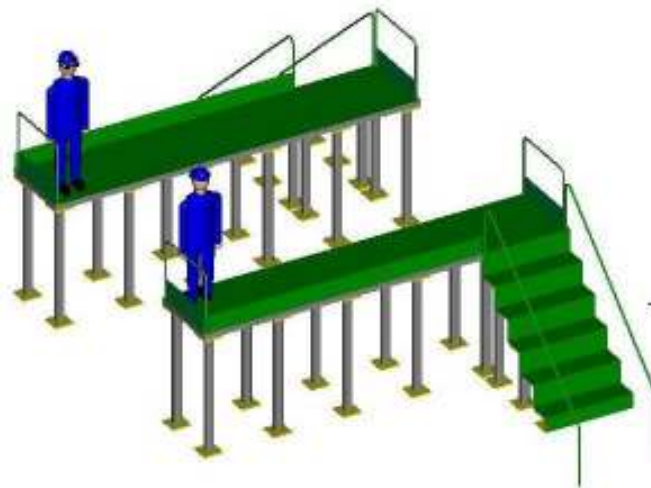
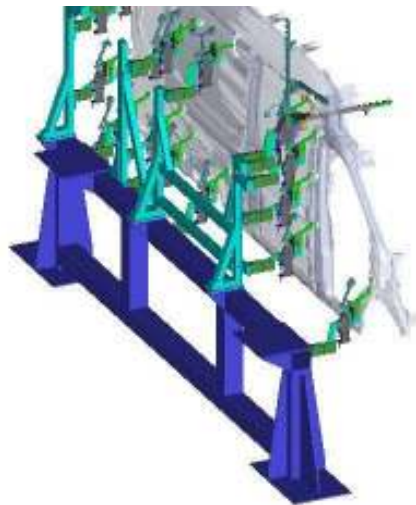
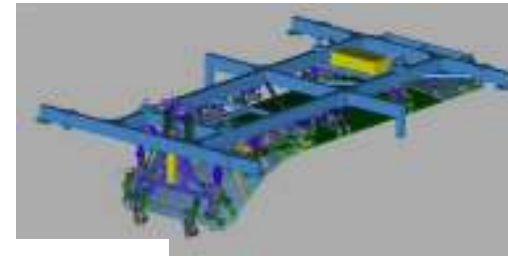
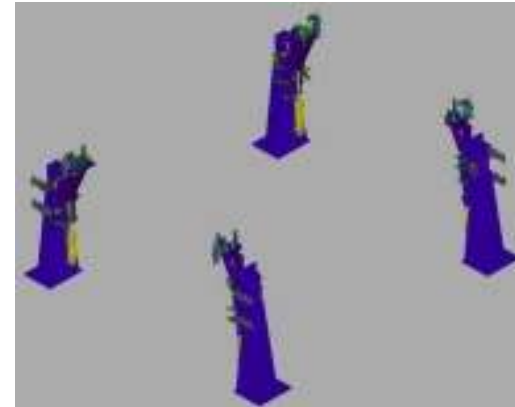
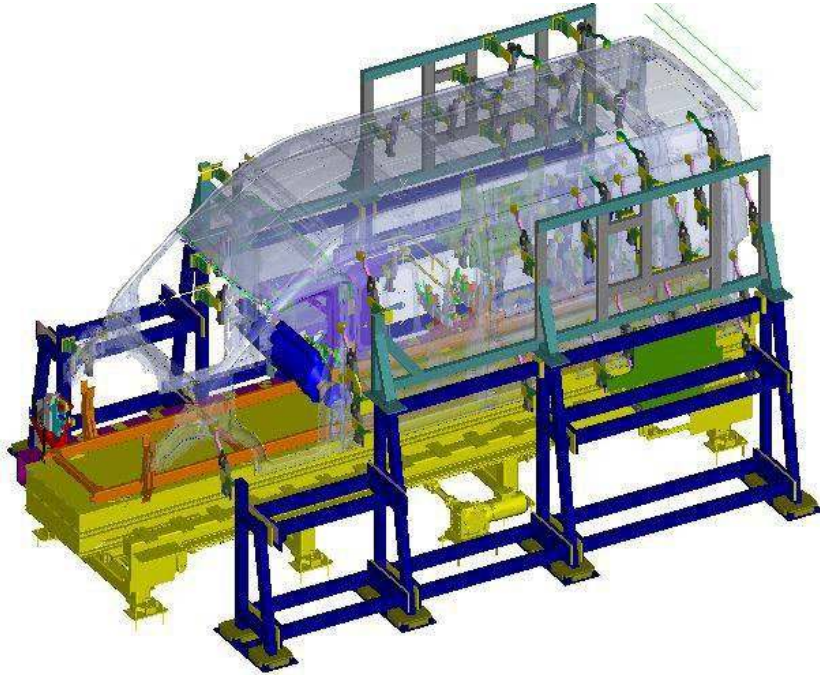

Body side & Roof welding



SMT

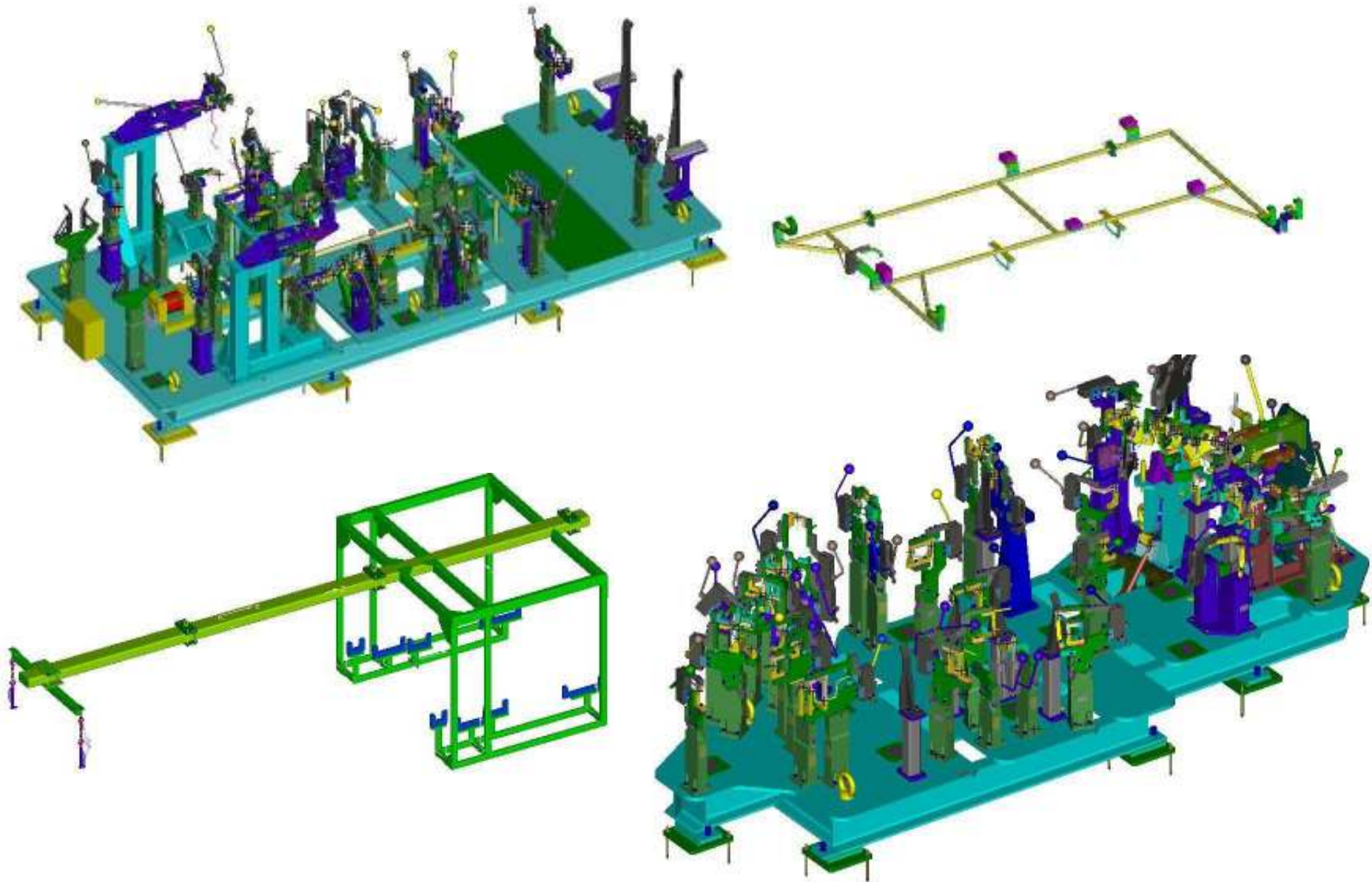

Dash & Floor assembly



SMT

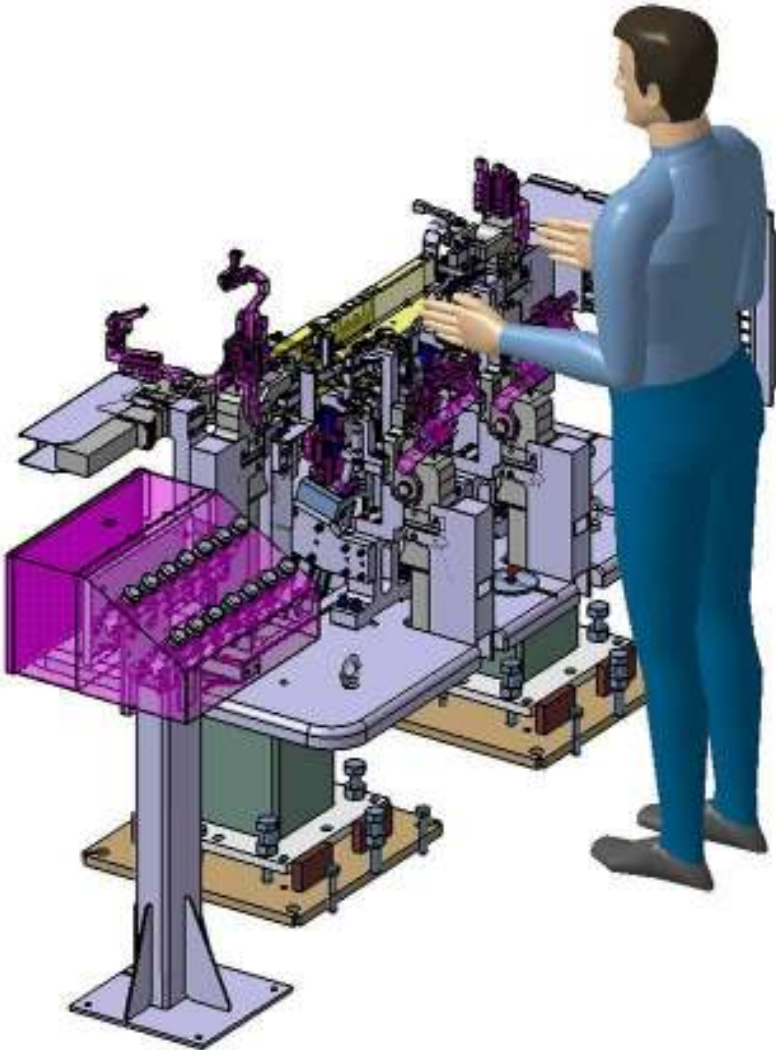
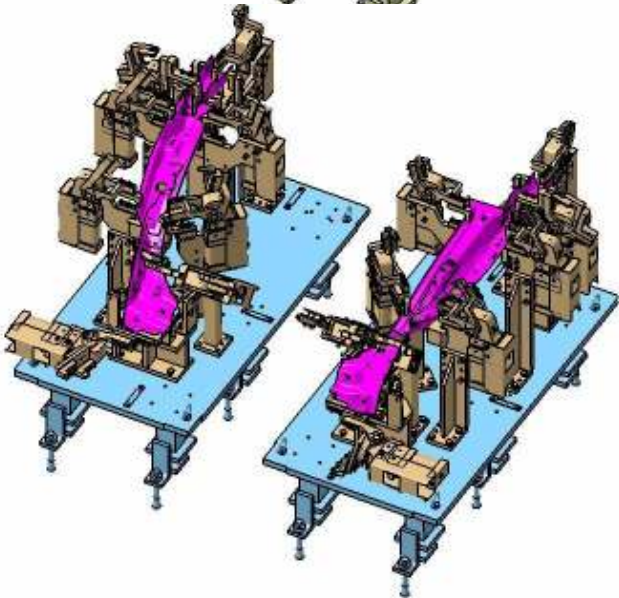
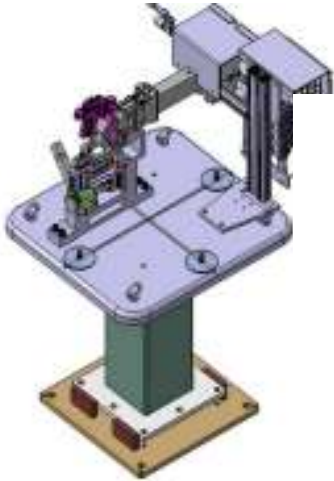
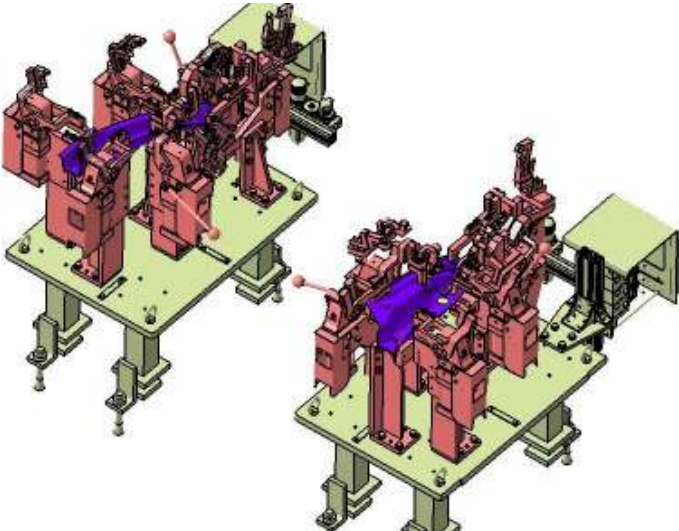

DV5 & 1.5 sigma Exhaust Pipe Arc Welding

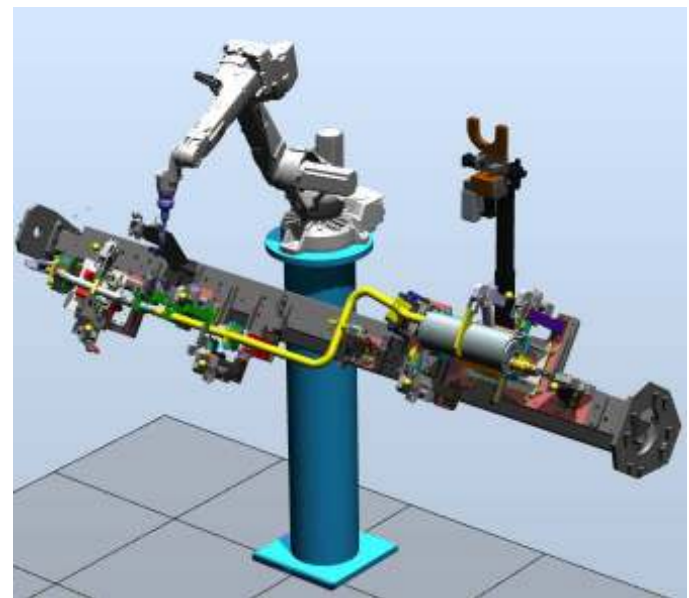
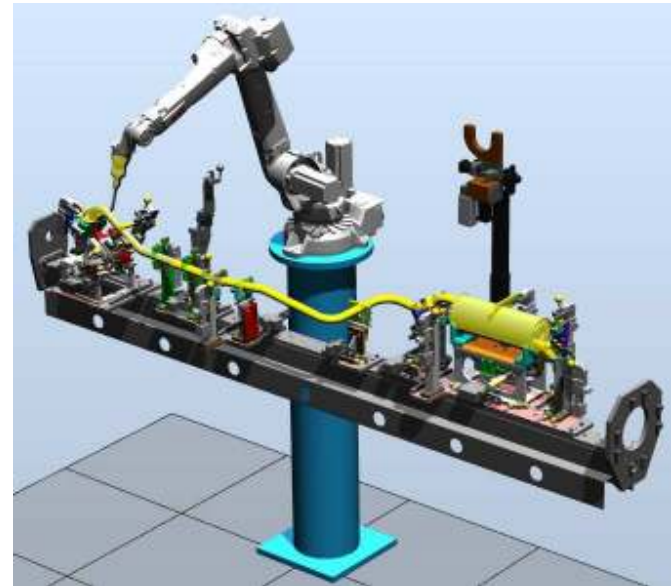
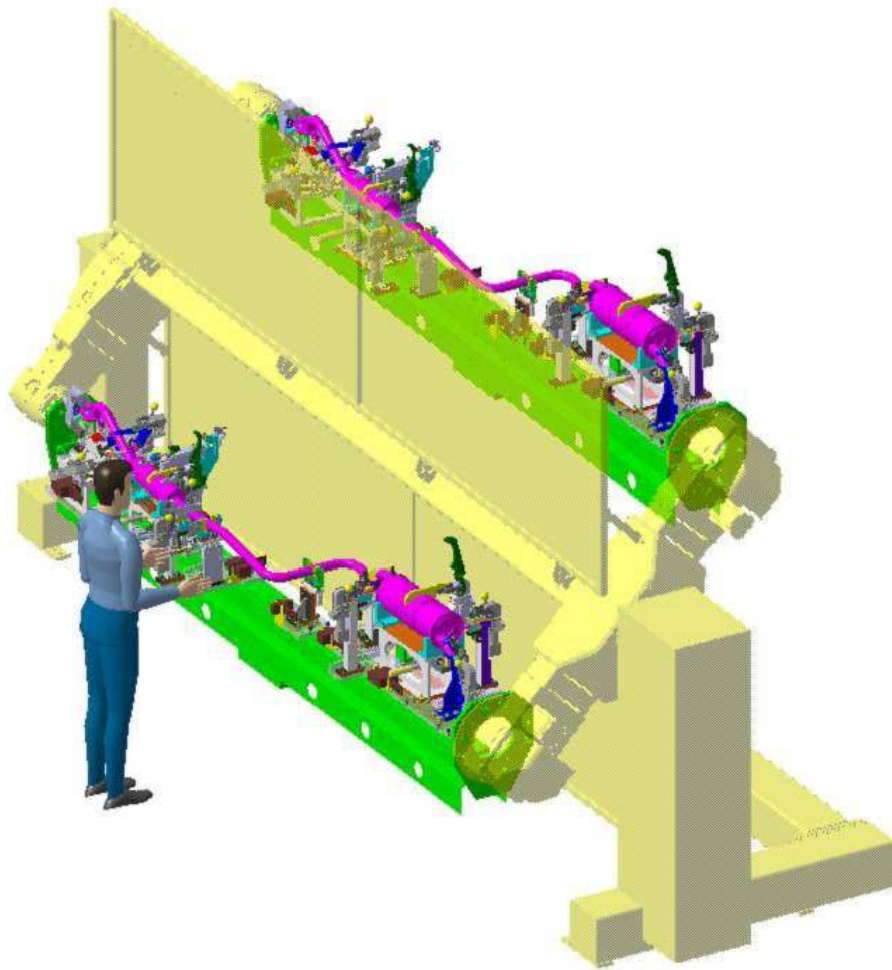

Arc Welding fixture for Automotive component



SMT

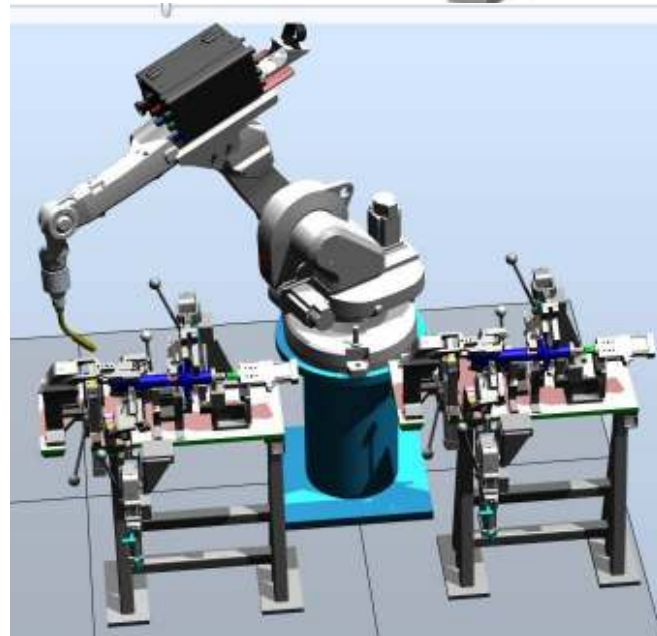
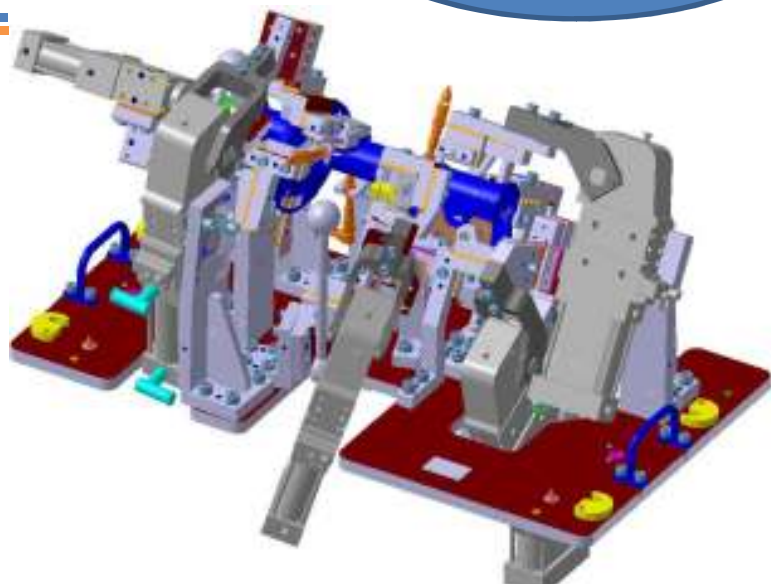
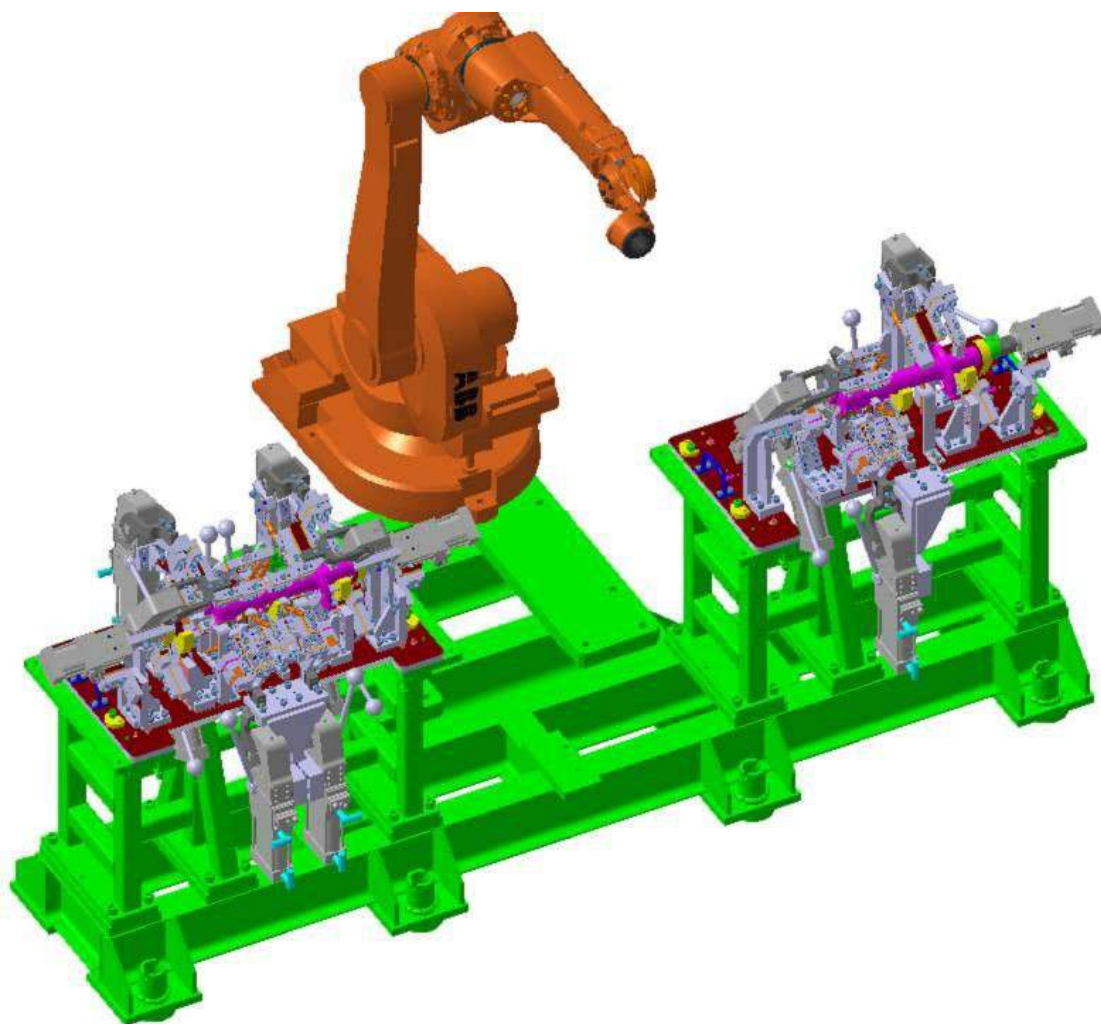

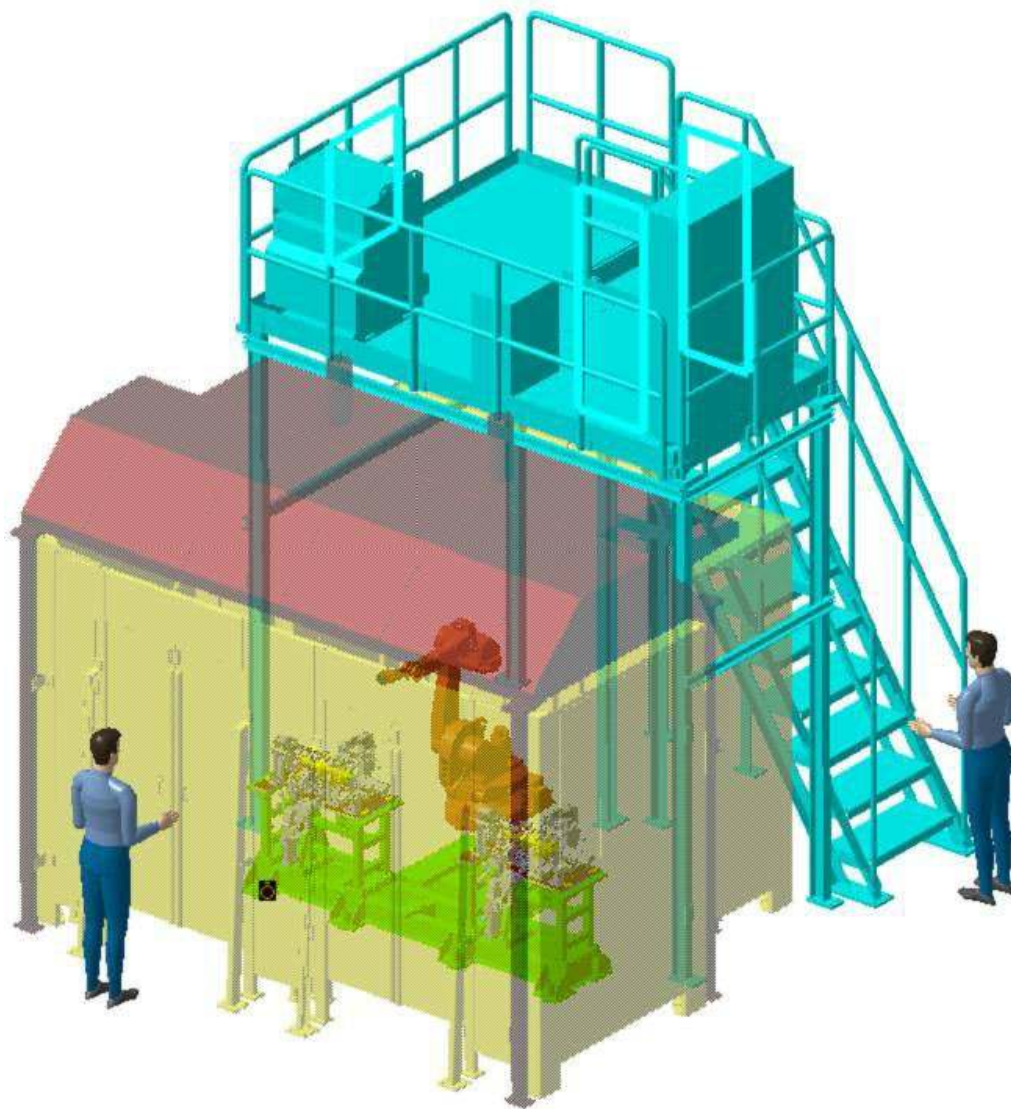

Hard Gauges – Checking fixture



FORD INDIA PRIVATE LIMITED(FIPL) - PROJECT "B562"

3

REV	REVISION CONTENTS	DATE	ISSUE	REMARKS
01				
02				
03				
04				
05				
06				
07				
08				
09				
10				
11				
12				
13				
14				
15				
16				
17				
18				
19				
20				

REV	REVISION CONTENTS	DATE	ISSUE	REMARKS
01				
02				
03				
04				
05				
06				
07				
08				
09				
10				
11				
12				
13				
14				
15				
16				
17				
18				
19				
20				

REV	REVISION CONTENTS	DATE	ISSUE	REMARKS
01				
02				
03				
04				
05				
06				
07				
08				
09				
10				
11				
12				
13				
14				
15				
16				
17				
18				
19				
20				

REV	REVISION CONTENTS	DATE	ISSUE	REMARKS
01				
02				
03				
04				
05				
06				
07				
08				
09				
10				
11				
12				
13				
14				
15				
16				
17				
18				
19				
20				

REV	REVISION CONTENTS	DATE	ISSUE	REMARKS
01				
02				
03				
04				
05				
06				
07				
08				
09				
10				
11				
12				
13				
14				
15				
16				
17				
18				
19				
20				

REV	REVISION CONTENTS	DATE	ISSUE	REMARKS
01				
02				
03				
04				
05				
06				
07				
08				
09				
10				
11				
12				
13				
14				
15				
16				
17				
18				
19				
20				

REV	REVISION CONTENTS	DATE	ISSUE	REMARKS
01				
02				
03				
04				
05				
06				
07				
08				
09				
10				
11				
12				
13				
14				
15				
16				
17				
18				
19				
20				

REV	REVISION CONTENTS	DATE	ISSUE	REMARKS
01				
02				
03				
04				
05				
06				
07				
08				
09				
10				
11				
12				
13				
14				
15				
16				
17				
18				
19				
20				

FORD INDIA PRIVATE LIMITED(FIPL) - PROJECT "B562"

REV	REVISION CONTENTS	DATE	ISSUE	REMARKS
01				
02				
03				
04				
05				
06				
07				
08				
09				
10				
11				
12				
13				
14				
15				
16				
17				
18				
19				
20				

REV	REVISION CONTENTS	DATE	ISSUE	REMARKS
01				
02				
03				
04				
05				
06				
07				
08				
09				
10				
11				
12				
13				
14				
15				
16				
17				
18				
19				
20				

REV	REVISION CONTENTS	DATE	ISSUE	REMARKS
01				
02				
03				
04				
05				
06				
07				
08				
09				
10				
11				
12				
13				
14				
15				
16				
17				
18				
19				
20				

REV	REVISION CONTENTS	DATE	ISSUE	REMARKS
01				
02				
03				
04				
05				
06				
07				
08				
09				
10				
11				
12				
13				
14				
15				
16				
17				
18				
19				
20				

REV	REVISION CONTENTS	DATE	ISSUE	REMARKS
01				
02				
03				
04				
05				
06				
07				
08				
09				
10				
11				
12				
13				
14				
15				
16				
17				
18				
19				
20				

REV	REVISION CONTENTS	DATE	ISSUE	REMARKS
01				
02				
03				
04				
05				
06				
07				
08				
09				
10				
11				
12				
13				
14				
15				
16				
17				
18				
19				
20				

REV	REVISION CONTENTS	DATE	ISSUE	REMARKS
01				
02				
03				
04				
05				
06				
07				
08				
09				
10				
11				
12				
13				
14				
15				
16				
17				
18				
19				
20				

FORD INDIA PRIVATE LIMITED(FIPL) - PROJECT "B562"

REV	REVISION CONTENTS	DATE	ISSUE	REMARKS
01				
02				
03				
04				
05				
06				
07				
08				
09				
10				

Hard Gauges – Checking fixture



SMT

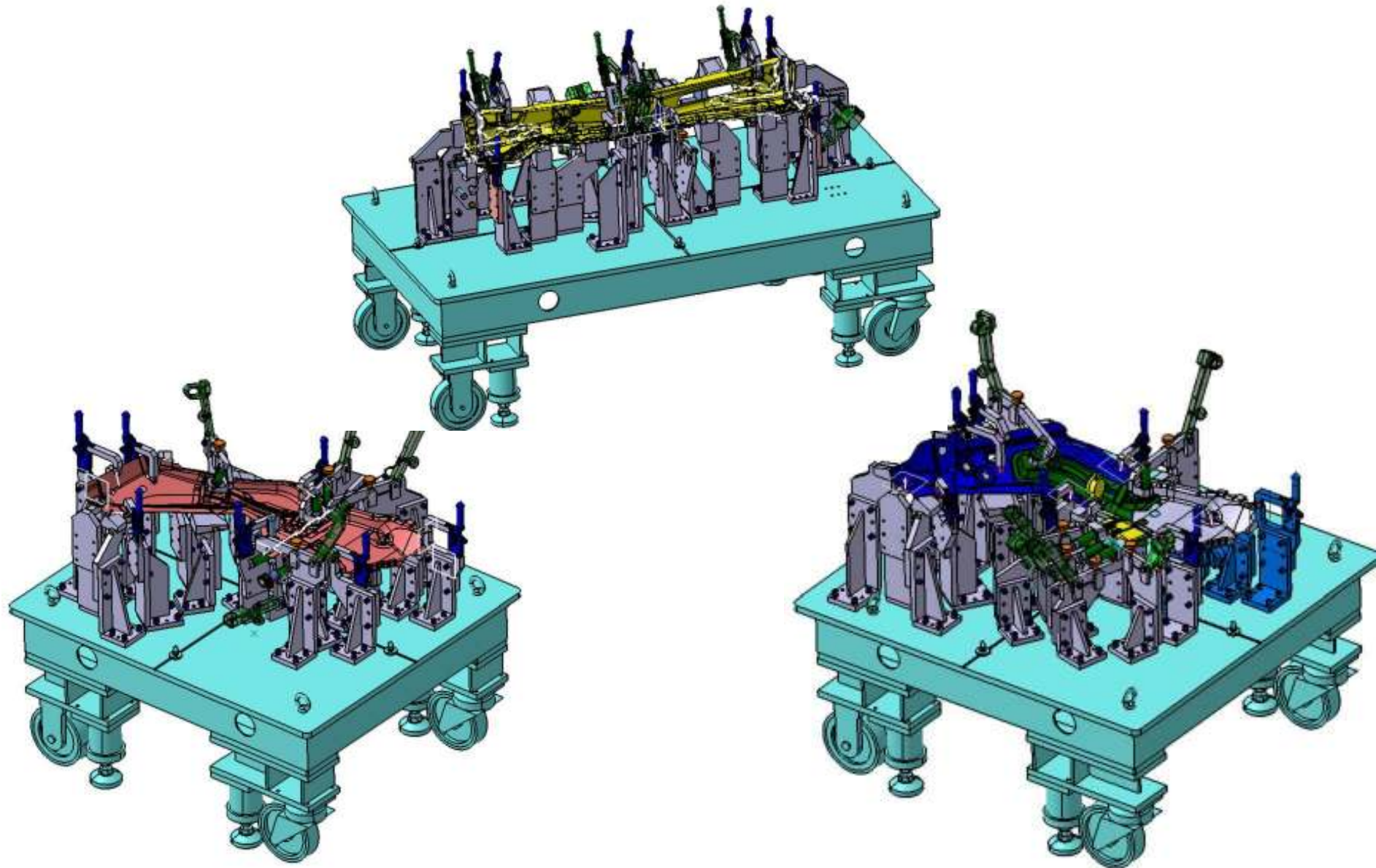





SMT

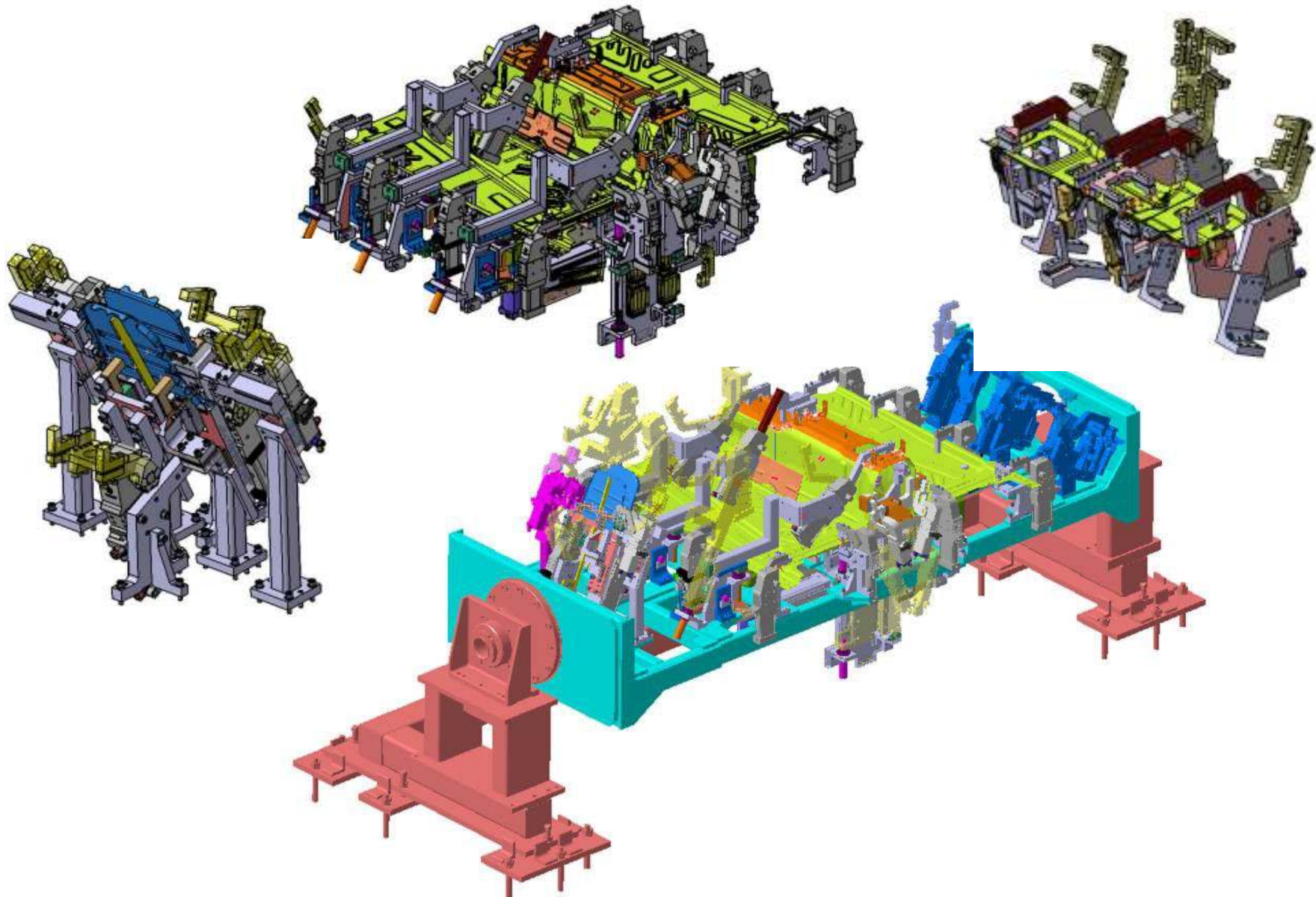

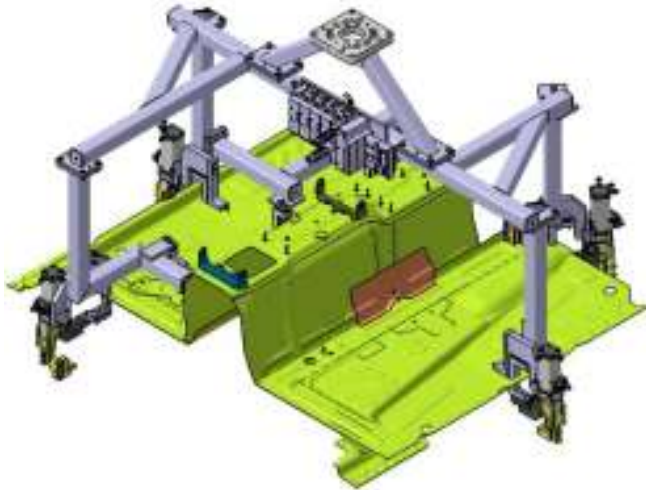
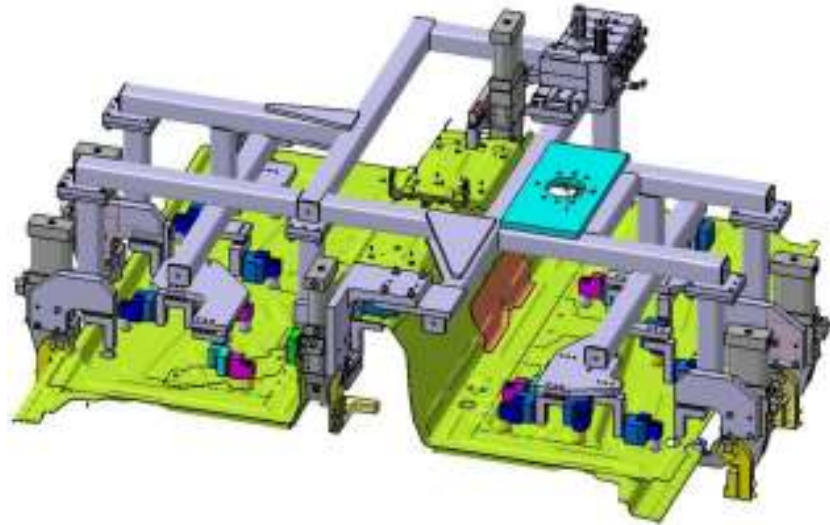
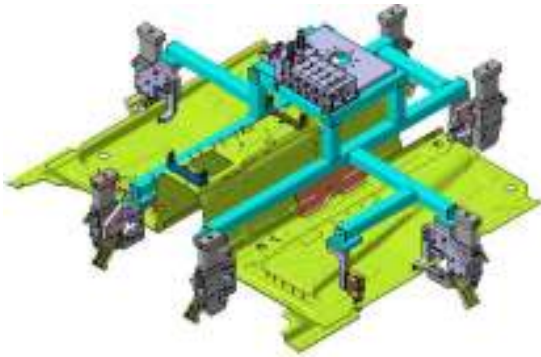

Camaro Roof rail Assembly



SMT

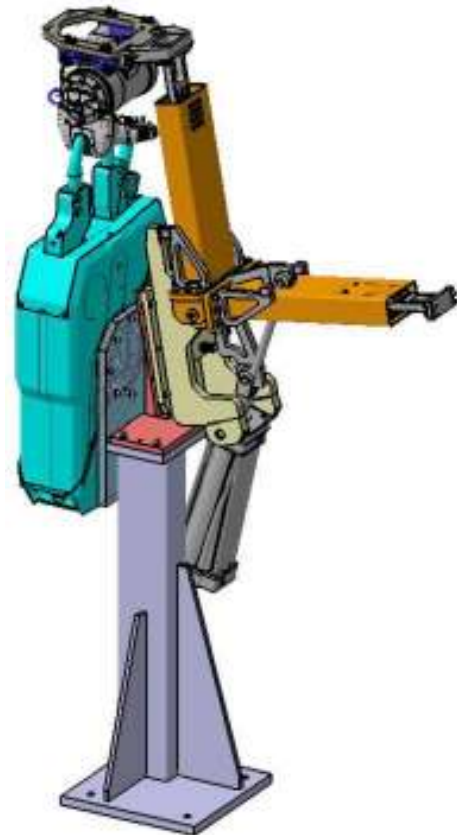
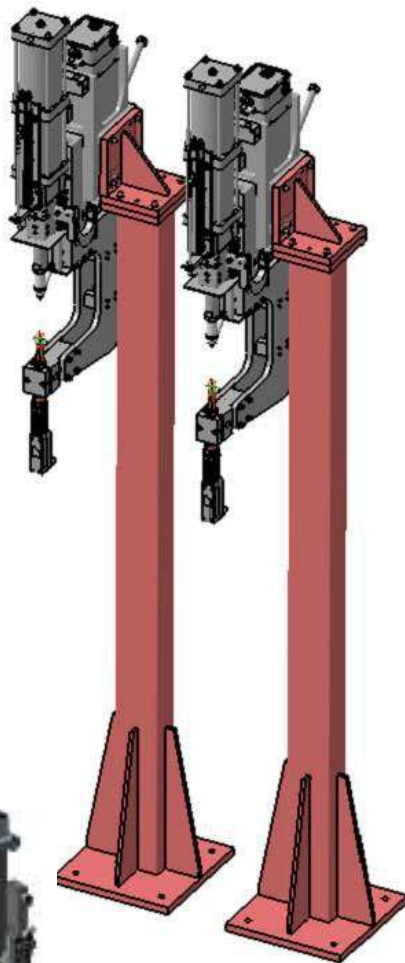

Rear wheel House Assembly



SMT

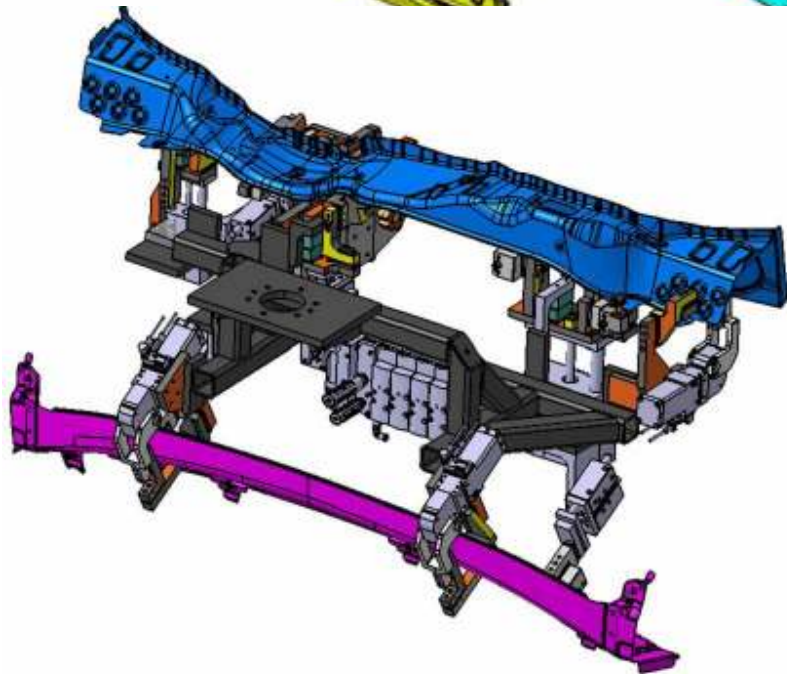
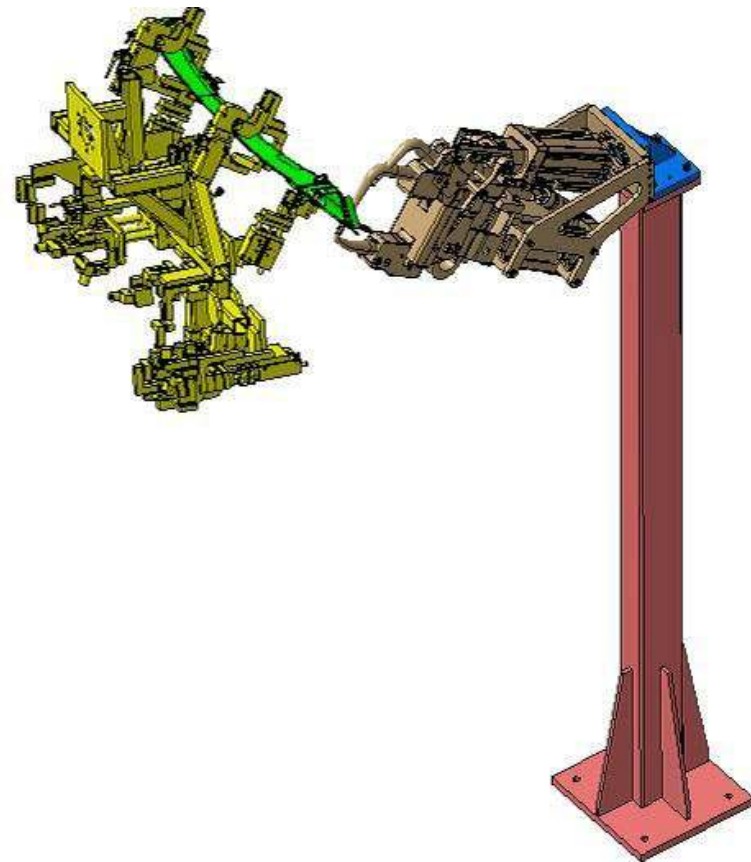
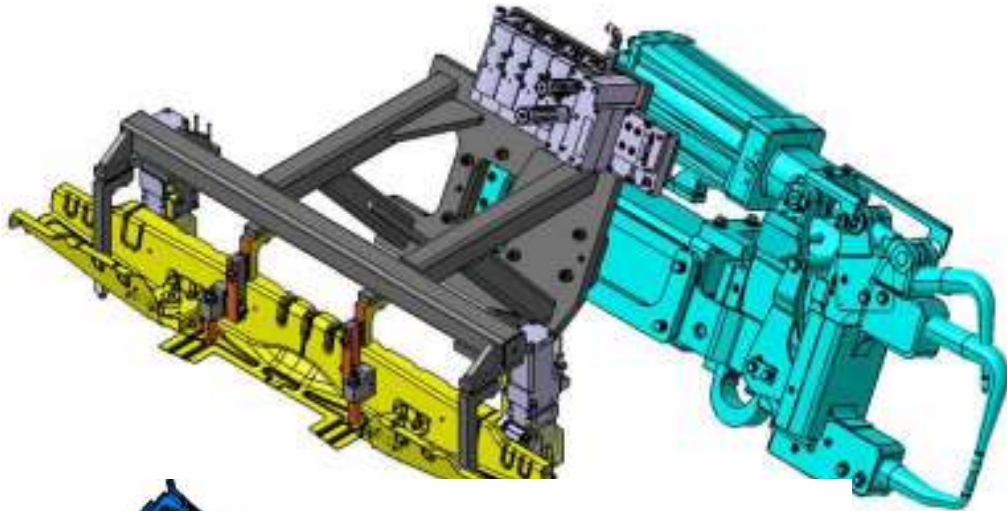



SMT

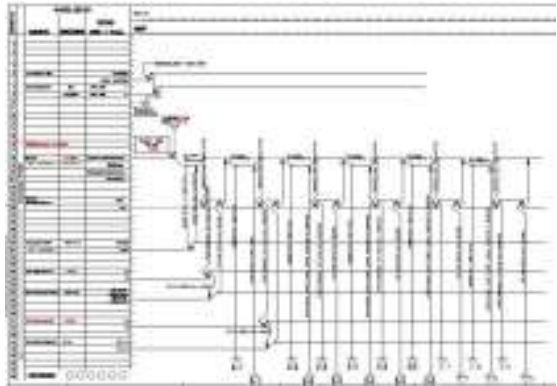
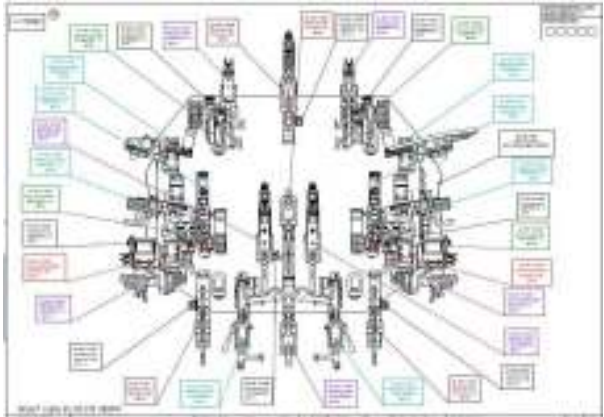
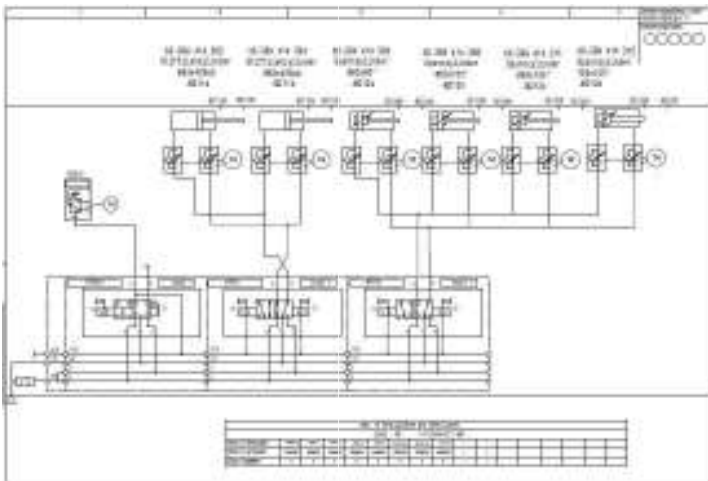
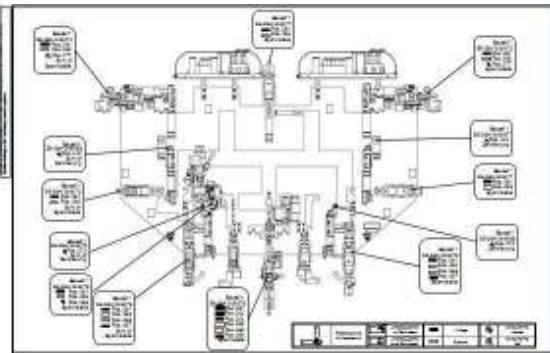



SMT

