



AUTHORISED ACCESS ONLY.



Ensuring security and crowd management at the entrance in areas such as railway platforms, passenger terminals, sports stadiums, etc. is a challenging task. To make this difficult task easier, Godrej Security Solutions presents **VigiGuard Slim Tripod Turnstile**.

Designed for pedestrian entrance control, it opens only for those with authorised access. Its rotating arms allow one person through at a time.

APPLICATIONS:

Indoor applications like corporate offices, IT parks, airports, large business facilities etc.



FEATURES & BENEFITS

- Electro mechanical mechanism
- 3 x 120 degree rotating tripod arms
- Bi-directional operational control
- Self-centering mechanism with hydraulic damping
- Integrated with access control
- Case work available in mild steel powder coated or stainless steel 304, with stainless steel arms
- Lockable casing
- 380mm or 500mm walkway (standard is 380mm)

SPECIFICATIONS

Power Supply	230 VAC @ 50-60 Hz
Power Consumption (approx. watts)	40
Duty Cycle	Intensive use
Lane Indicator	Built-in (Green/Red)
Application	Indoor
Reader Mounting Place (approx. mm)	100 X 250
Dimension of Case Work (approx. mm)	420 X 250 X 1020
Walkway (mm)	380 or 500
Installation	By anchor bolts on plain surface

OPTIONAL FEATURES

- Automatic drop arm feature in case of emergency
- Sensor based auto swirl
- Case work - stainless steel-316

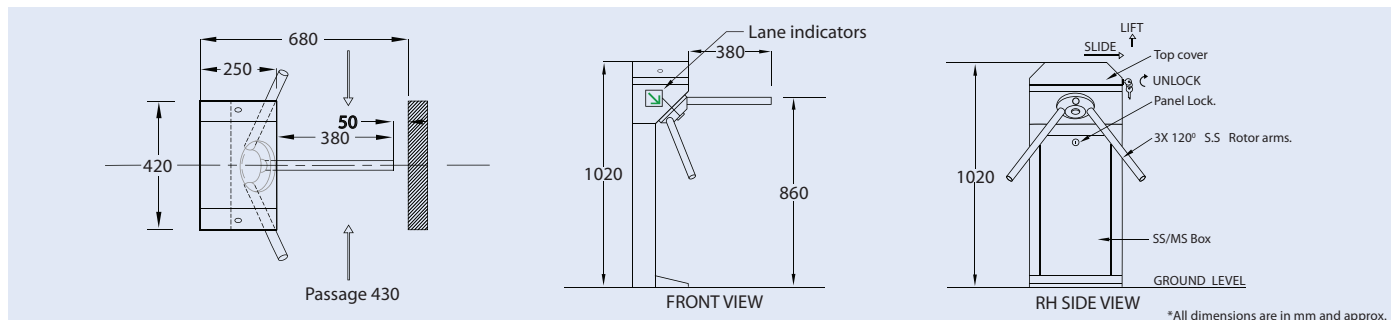

Disclaimer: In view of the Godrej policy of continuous development and improvement, the dimensions and specifications may be changed without prior notice or obligation. Colours of the products shown in this catalogue may not match the actual colour of the product due to printing limitations.



Godrej & Boyce Mfg. Co. Ltd.

Plant No. 17, Pirojshanagar, Vikhroli (E), Mumbai-400 079

Tel. No.: 022 6796 1700/1800 Fax No.: 022 6796 1509

Toll-Free No.: 1800 209 99 55 | SMS 'GSS' to 53636 | secure@godrej.com | www.godrejsecure.com

(Service across 20 branches and an extensive dealership network.)

ISO 9001:2008 & 14001:2004 & OHSAS 18001:2007

Follow us on:

