

NEW SUPER ENGINEERS

Mfrs. & Suppliers, All Types Engineering Equipments for Hydro Power Project & Other Project.

Wet Shotcreting Machine

N.S.E.-1100

Wet or semi the optimal spraying

- ▶▶ Tunnel Construction
- ▶▶ Reconditioning
- ▶▶ Slope Consolidation
- ▶▶ Excavation Securing



N.S.E.-1100

Technical data and available machine versions

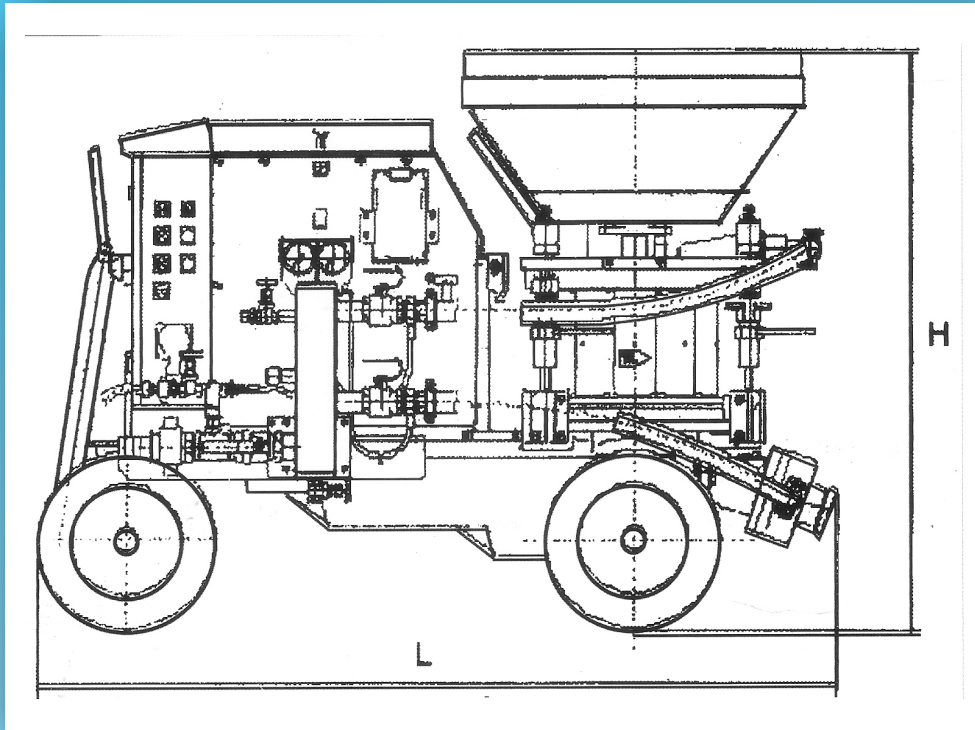

N.S.E.-1100

Length	1900 mm
Width	900 mm
Height 10 litre	1280 mm
Height 16 litre	1380 mm
Weight	1200 kg.

N.S.E.-2000

Length	2430 mm
Width	1050 mm
Height with wheels	1350 mm
Height without w.	1170 mm
Weight	1550 kg.

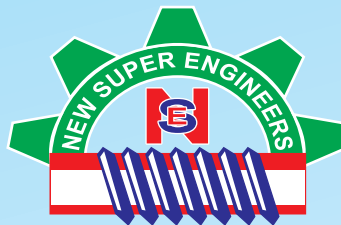

NEW SUPER ENGINEERS

11/324, Yahiya Shah, Pacca Bagh, Saharanpur - 247001 (U.P.)

Mob. : 99171-10559, 7983817185, 9917032223

Email : newsuperengineers120@gmail.com

Versatility of use

We shotcreting procedure is based on high-density principle ensuring that placed shotcrete has the same characteristics as the structural concrete.

Designed specifically to meet the demand of shotcreting operations N.S.E.-1100 wet shotcreting unit is equipped with all the components required for high-density Pneumatic conveyance.

Whether for tunneling, civil engineering structures, excavation support, the N.S.E.-1100 has proven in dams, hydroelectric power projects.

The machine gives years of service for its out standing quality its superior design keep wear down to an absolute minimum N.S.E. is guarantee for support & quick delivery for spare parts.

N.S.E.-1100 shortcrete machine is suitable for spraying wet & semi wet mixes up to 16 mm grain size without need to convert the machine or to use additional component it is possible to switch within few minutes from semi wet to wet spraying.

The ready-mix concrete plant delivers the prepared standard concrete with a water/cement ratio 0.5. The plasticizer is added and mixed in direct in the truck mixer just before the shotcrete is filled into th happen of shotcrete machine.

Using DN 65 hose from the reducer of the wet shotcrete unit to the turbo injector nozzle a maximum working range from the shotcrete machine location is attained. A separate hose is connected to the turbo injector nozzle from the dosing unit for accelerating agent to swirl int he airflow of the nozzle to mix the agent into the shotcrete.

Flexible :

Wet, semi wet mix spraying without conversion of the machine. This is for consolidation of dry and water bearing rock formations. No need for a pumpable mix with the wet spraying thin stream method.

User friendly:

Easy filling, fast cleaning and four-point precision fastening.

Fit for the future:

Ready to be used with output - controlled additive dosage equipment. Addition of steel fibers, becoming more & more important, is possible without any problem.

Designed for minimum maintenance :

Closed, maintenance-free spur-wheel drives with approx. 95% efficiency and self-lubrication sealing plates, which reduces wear and thus maintenance costs.

► **Flexible** ► **User-friendly** ► **Fit for the Future** ► **Minimum maintenance**

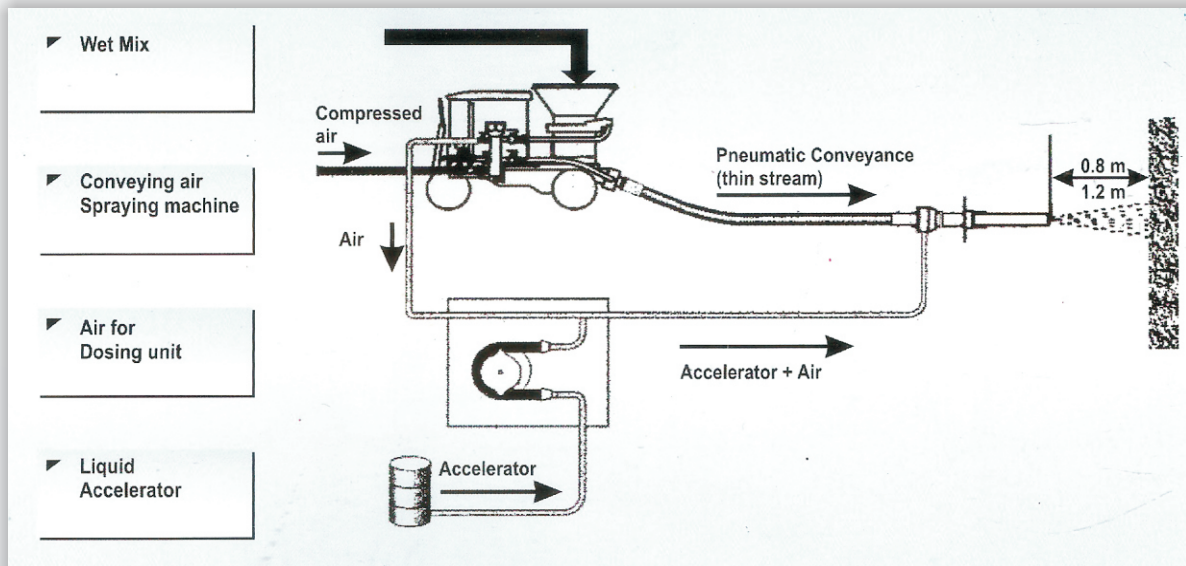

#Spraying for Wet Shotcreting



OPTIONS	N.S.E.-1100 Standard ex stock	N.S.E.-1100 Custom on order	N.S.E.-2000 Standard on stock	Rotor Volume	Output
Mounting	wheel	skid / without	wheel	10 litre	5-7 m ³ / h
Rotor volume	16 litre	10 litre	15 litre	10 litre	5-7 m ³ / h
Rotor type	normal	dubber-lined	normal	16 litre	7-10 m ³ / h
Drive	400 V / 50 Hz Protection IP 55	220 V / 440 V 50 Hz / 60 Hz without / special	400 V / 50 Hz Protection IP 55	25 litre	9-21 m ³ / h 9-21 m ³ / h

N.S.E.-20M

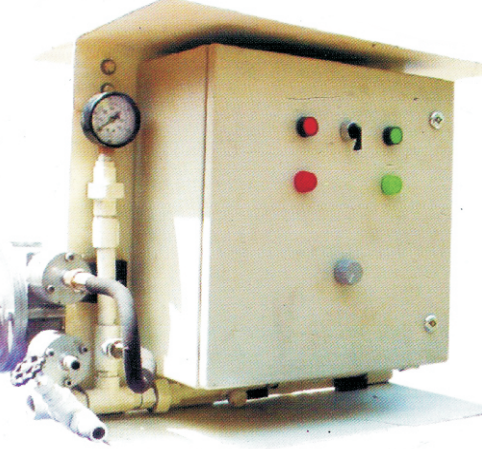

Dosing Pump

N.S.E.-0450



Sand Blasting Mach.

N.S.E.-0301

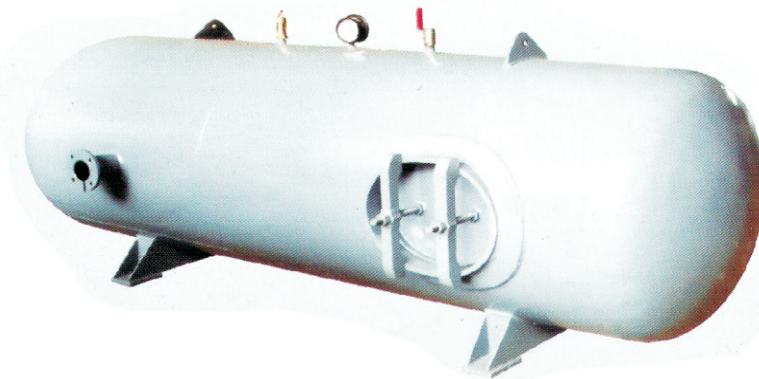

Air Receiver Tank

N.S.E.-0401

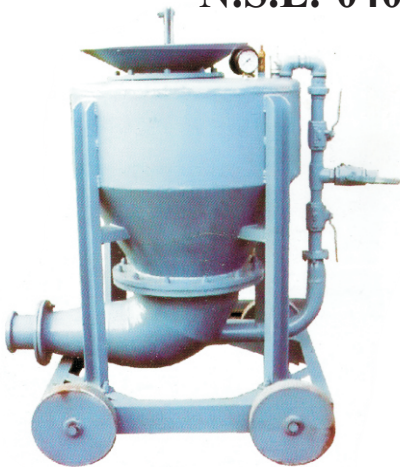

Concrete Placer

N.S.E.-0018p

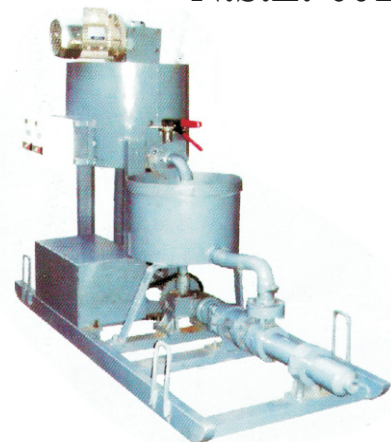

Grout pump

Concrete pump accessories
Pipe Line & All Types Bands Reducer

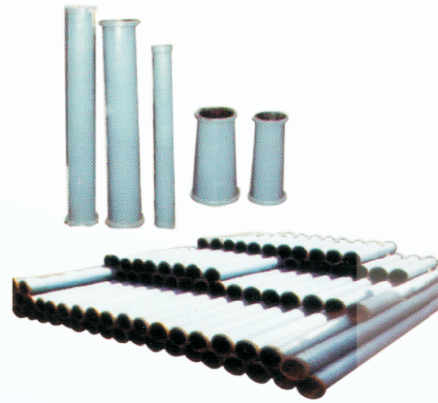
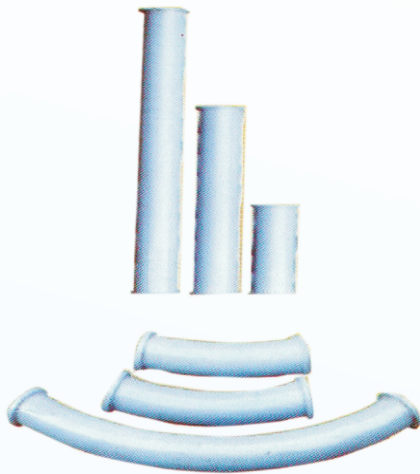

Rib Bending Mach.

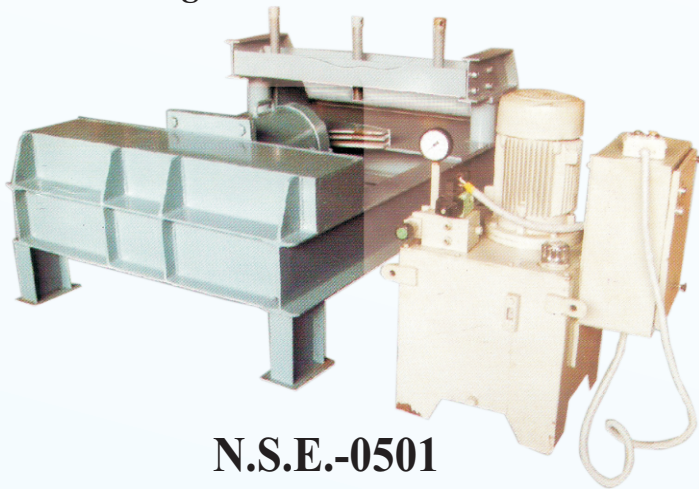

N.S.E.-0501

Jack & Power Pack

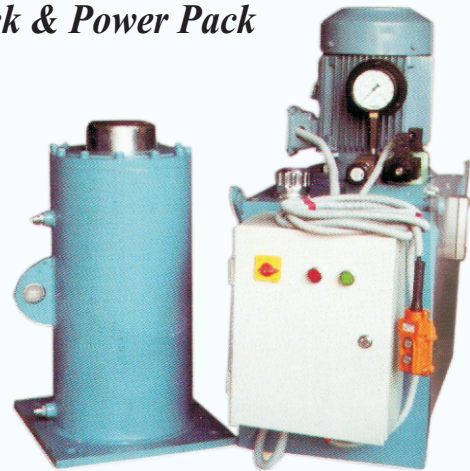

N.S.E.-0500

Co-Axial Flow Fan
N.S.E.-3600

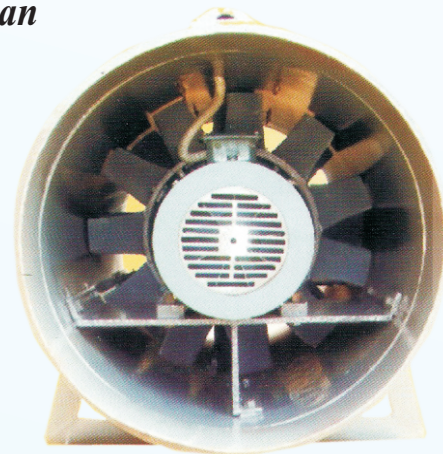

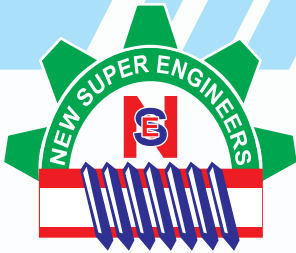

NEW SUPER ENGINEERS

Mfrs. & Suppliers, All Types Engineering Equipments for Hydro Power Project & Other Project.

N.S.E. Product Range

N.S.E.-1100 Shortcrete machine is suitable for spraying Wet & Dry mixes up to 16 mm grain size without need to convert machine.

AREAS OF USE :

- ❖ Tunnel construction
- ❖ All Civil engineering works
- ❖ Building excavations
- ❖ Slopes and hillsides

N.S.E.-1100



Wet-Shortcrete

N.S.E.-0111



Dry-Shortcrete

N.S.E.-0032



Group Pump

N.S.E.-0040 HP

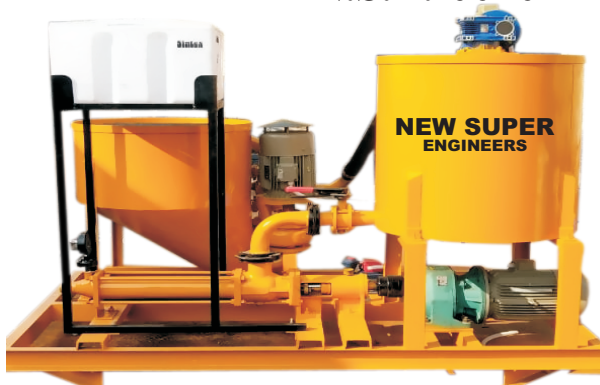

Grout Pump

N.S.E.-0032 & N.S.E.-0040 HP

AREAS OF USE :

The proven mixing and pumping technology is especially suitable for :-

- ❖ Drill whole filling
- ❖ Back filling
- ❖ Anchor mortar

Mini Mobile Concrete Batching & Mixing Plant Reversible Drum Type

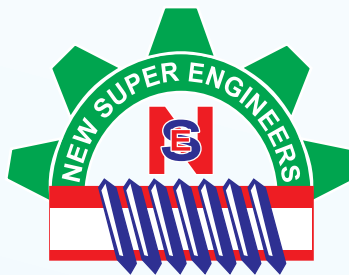

NEW SUPER ENGINEERS

11/324, Yahiya Shah, Pacca Bagh, Saharanpur - 247001 (U.P.)

Mob. : 99171-10559, 7983817185, 9917032223

Email : newsuperengineers120@gmail.com