

Make A Healthy Living, A Way Of Life



**PURE**  
AN ISO 9001:2015 Certified Company

**SHREEJA**  
Health Care  
Products

House of Purity

India's 1<sup>st</sup>

OIL MAKER MACHINE MANUFACTURER

WWW.SHREEJAHEALTHCARE.COM



MINI COMMERCIAL OIL MAKER MACHINE MANUAL

CUM

WARRANTY CARD

1

Congratulations



SH- 1200

Dear Customer,

Our Heartiest Welcome Goes To You. Thanks For Being A Proud Customer Of Our Unique And Ever-expanding Line Of Products.

Our Products Is Engineered To Perfection, Assembled With At Most Care As Multi-level Quality Control System To Ensure Trouble Free Operation For Years To Come. please, Read The Instructions In The Manual Carefully And We're Honoured To Have You With Us Always!

DATE OF PURCHASE :
NAME OF PURCHASER :
BILL / INVOICE / CASH MEMO NO. :
DEALER'S STAMP & SIGNATURE
This warranty is not valid if above information is not duly filled in
We warrants this machine to be free from defects in materials and workmanship under normal use for a period of one(1) year from the date of purchase, as evidenced by the purchase receipt.
During the warranty period We shall repair the machine if defective. This warranty is limited to the purchaser and is not transferable.
*One year warranty only for electric motor & temperature controller.*

**SHREEJA HEALTH CARE PRODUCTS**

Regd. Office : 26, Ground Floor, Ratnasagar Apartment,  
Near Varachha Police Station, Surat - 395 006, Gujarat, India

Email : shreejahealthcare@gmail.com

Website : www.shreejahealthcare.com

"Destination of Purity"

## 2

### Specification



MODEL	: SH-1200
TYPE	: COLD PRESS
IN PUT VOLTAGE	: 220-240 VOLT AC
TOTAL POWER	: 1200 WATT
MOTOR POWER	: 0.8 HP
POWER CONSUMPTION	: 1.2 UNIT / 1 HRS MACHINE WORK
RPM	: 72 ROTATION PER MINUTE
CAPACITY	: 8 – 10 KG / HRS (ACC. TO MATERIAL SIZE)
KEEP WORKING	: 10 – 12 HRS CONTINUES
WEIGHT	: 40 KG
SIZE	: 24(L) * 9(W) * 24(H) INCH
WARRANTY	: 1 YEAR *

### ADVANTAGES :

HOME MADE PURE EDIBLE OIL IN FRONT OF YOUR EYES ONLY AND THE SLUG GENERATED IS ALSO EDIBLE IN VARIOUS APPLICATION, LIKE...USE AS GRAVY FOR MAKING VEGETABLE AND ALSO USE IN MAKING SWEET.

### FEATURES:

- ◆ HEAVY DUTY MOTOR
- ◆ EASY TO CLEAN
- ◆ ZERO MAINTENANCE
- ◆ EASY TO FEED
- ◆ EASY TO OPERATE

### फायदा :

शुद्ध तेल आपकी आँखों के सामने बनता है खाने लायक खली निकलता है सब्जी की ग्रेवी और मिठाई बनाने में उपयोगी है।

### विशेषता :

- ◆ हेवी ड्यूटी मोटर
- ◆ सफाई में सरल
- ◆ जीरो मेन्टेनेन्स
- ◆ सफाई फीडिंग
- ◆ उपयोग में सरल

# अब तो जागो, रिफाइंड ओइलसे भागो



## शुद्ध तेल के फायदा

- 60 प्रतिशत रोग जो वायु से उत्पन्न होते हैं, वह नियंत्रण में रहते हैं।
- रोग प्रतिकारक शक्ति बढ़ता है।
- जोंडो के रोग में अत्यंत लाभदायी है।
- हृदय से जुड़े रोगों का भय घटाता है।
- केन्सर को रोकने में मदद करता है।
- कोलेस्ट्रॉल के लेवल को नियंत्रण में रखते हैं।
- दांत को मजबूत करता है।



## BENEFITS OF PURE OIL

- 80% DISEASE WHICH IS CREATED BY GAS CONTROLLED.
- BOOST IMMUNE SYSTEM.
- IT IS BENEFICIAL IN JOINT DISEASE.
- REDUCES RISK OF HEART DISEASES.
- HELPS TO PREVENT CANCER.
- HELPS TO MAINTAIN CHOLESTEROL LEVELS.
- INCREASE THE PULSE OF THE TOOTH.



## रिफाइंड तेल यानी जहर

बेकार तेल और पामोलीन तेल केमिकल प्रोसेस से तैयार होता है जिसमें फोस्टिक सोडा, हेक्जेन जैसे खतरनाक केमिकल का इस्तेमाल होता है। जिसे आप रिफाइंड ऑइल कहते हैं। जिसे खाने से केन्सर, हृदयरोग, जोड़ो का दर्द, गैस, एसिडिटी, कब्जीयात इत्यादि रोग होते हैं।



## REFINED OIL MEANS POISON

REFINED OIL MEANS POISON-CRUDE OIL & PAMOLINE OIL ARE BEING PREPARED WITH HELP OF CHEMICAL PROCESSING CONTAINING CAUSTIC SODA & HEXANE WHICH YOU ARE CALLING IT HAS A REFINED OIL. -WHICH LEADS TO CANCER ARTHRITIS AND SEVERAL OTHER DISORDERS.

## OIL OUTPUT

Nuts	दिएखल	बीज		Yield
Groundnut	मगड़णी	मूंगफली		40 - 45 %
Sesame	तल	तिल		42 - 52 %
Sunflower	सूर्यमुष्पी	सूरजमुखी		18 - 25 %
Mustard	सरसव (राई)	सरसों		25 - 35 %
Almond	बदाम	बादाम		40 - 45 %
Coconut	नाणियेर	नारियल		45 - 55 %
Walnut	अपरोट	अखरोट		30 - 40 %
Soyabean	सोयाबीन	सोयाबीन		10 - 14 %

Note : Oil yield depends on seeds quality only & Capacity depend on seeds size

3

## Machine Accessories



1. Hopper
2. Squeezing Tube
3. Squeezing Rods
4. Lock Pin
5. Slug Cover
6. Brush
7. Oil Collector
8. Oil Stainer
9. Hand Gloves
10. Power Cable



## 4 Installation

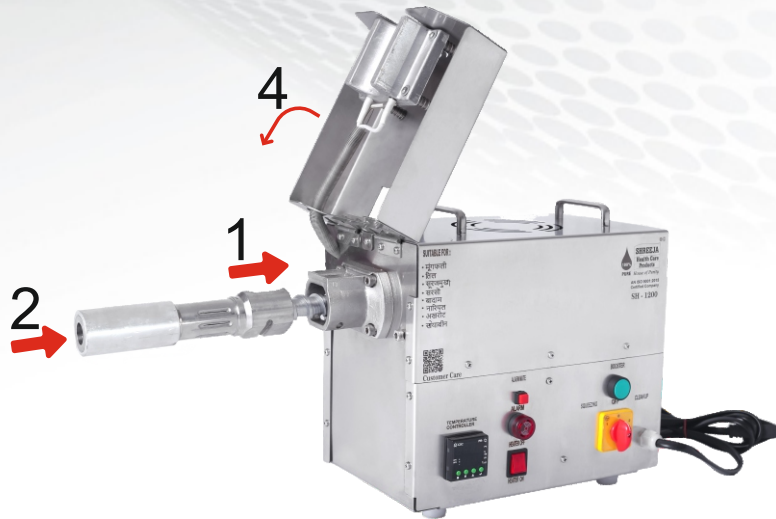

Before using the machine read the instruction carefully relating to the performance and operation of the machine.

Machine Should be plug in separate switch and should be provide earth connection to the machine.

The squeezing ROD should be inserted in the squeezing holder and then insert the squeezing tube in the holder and the locking pin should be inserted.

- Step 1 : Insert the Rod
- Step 2 : Insert the Tube
- Step 3 : Insert Lock Pin
- Step 4 : Close Front Cover

## 13 After Process



**Note :** Clean the tube and rod properly. Using hot and cold water and using the brush clean the front side of tube properly. Otherwise Rod will didn't insert the tube.

## 12 After Process

★ Must wear glove below steps

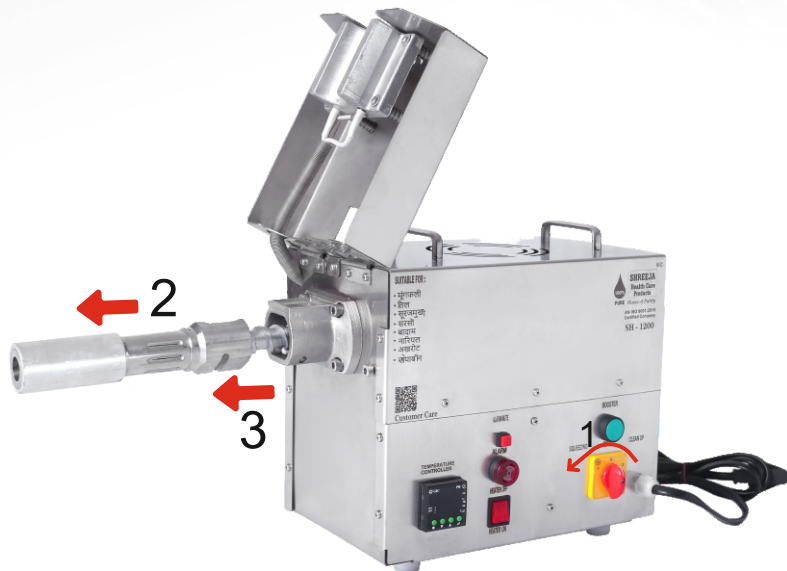

After removed the lock pin again switch on the squeezer button.

**Step 1 :** Switch on the Squeezer button.

**Step 2 :** Remove the tube (After switched on the squeezer button tube will automatically come out)

**Step 3 :** Remove the rod.

## 5 Installation



**Step 1 :** Switch on the Heater

**Step 2 :** Fix the Hopper

# 6

## TEMPERATURE REQUIRED FOR SEEDS

Groundnut	: 180 – 250° C
Sesame	: 220 – 250° C
Coconut	: 80 – 180° C
Almond	: 200 – 220° C
Mustard	: 180 – 200° C
Sunflower	: 200 – 220° C
Safflower	: 180 – 220° C
Walnut	: 180 – 230° C
Flax	: 100 – 200° C
Neem	: 180 – 200° C

# 11 After Process

★ Must wear glove below steps

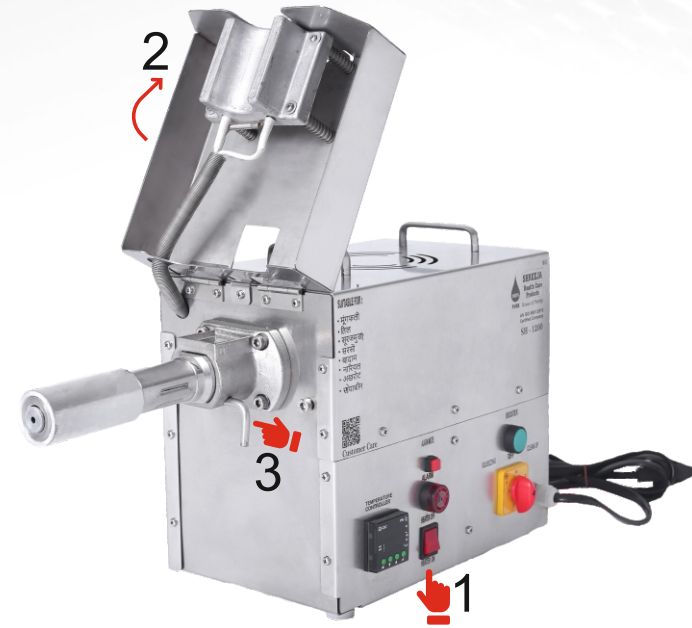

After this switch on the cleanup switch as it will be easy to take out the removing lock pin. After complete the squeezing process switched off the heater.

**Step 1** : Switch off the heater

**Step 2** : Open the Front cover

**Step 3** : Remove the lock pin

## 10 After Process



After complete the process put the reverse button (Yellow button Switched on the clockwise.)

**Step 1 :** Reverse (Cleanup), leave 1 minutes in reverse position

**Step 2 :** Press & leave the button

## 7 Pre Process



**Step 1 :** Set The Temperature Which You Have Extract

**Step 2 :** Press 2 For 3 Sec Than Display Will Show **SP1**

**Step 2A :** Press 2A decrease The Temperature

**Step 2B :** Press 2B Increase The Temperature

**Step 2C :** Press 2C To Save The Temperature

**Step 3 :** Further Press 2 For Finish The Process

**Step 4 :** After Reach The Temperature Alarm Will Blink Then Mute The Alarm Button.

## 8 Pre Process

1 ↓



The squeezer button should be switched on and the nuts should be added into the feed hopper.

**Step 1 :** Feed the seeds into the hopper.

## 9 Process



After reached the temperature switched on the squeezer button rotate the yellow button anti clockwise.

**Step 1 :** Start the machine (Squeezer)

1. Don't touch your hand in squeezing rod and tube While machine is running it will burn your finger.
2. During Process do not enter any hard part or finger on hopper.