



VISTARR
ENTERPRISES

“ You change your *Life.*
By changing your *air* ”





CONTENTS

AHU CEILING SUSPENDED UNIT	04
HORIZONTAL FLOOR MOUNTED AIR HANDLING UNIT	05-06
AIR HANDLING UNIT WITH HEAT RECOVERY WHEEL	07-08
UNITARY/VERTICAL UNITS	09
SINGLE & DOUBLE SKIN CEILING FAN COIL UNIT	10
AIR WASHER	11
AIR SCRUBBER	12
FRESH AIR UNIT	13
AIR EXHAUST	14
AXIAL FLOW FANS	15
COILS & FILTERS	16
ACCESSORIES	17

WHO WE ARE?

Vistaar Systems as one of the leading manufacturer of HVAC equipment is committed to create environmentally responsible building solutions that deliver energy performance, reduce power consumption and decreases life-cycle costs. We are committed to reduce our own impact on global climate change and motivate others do the same. In addition, we support green building initiatives by investing resources in the various industry committees and expertise in designing and manufacturing energy-efficient Air Handling products for HVAC applications.

Green Buildings Demand for environmentally responsible buildings *are* growing as realized by users and hence it is no more considered as a cost but as an investment. Green buildings are designed keeping energy efficiency, comfort, and sustainable materials in mind. At *Vistaar*, we understand the importance of supplying our customers an Air Handling Systems that should meet and conform to environmental standards while focusing on green-build initiatives that contribute to a more sustainable work environment. With architects, designers, customers, suppliers and our employees, *Vistaar* embraces environmental responsibility. As a leading supplier of HVAC systems and services, *Vistaar* is prepared to help the stake holders achieve their green building goals.

Vistaar custom made air handling units are specially designed to meet the most stringent project specifications for applications such as Hospitals, Pharmaceuticals, Process Industries, Hospitality, Institutions and industry clean rooms. *Vistaar* modular air handling units are based on a robust casing design and high quality components to provide the highest quality and reliability available in the market.

We, as one of the leading HVAC equipment manufacturers, can provide the exact solution. Our experience and expertise in designing, commissioning and maintaining HVAC systems not only guarantees a solution, it also gives you complete efficiency and peace of mind.

The *Vistaar* air handling units delivers Superior performance, Highest quality and reliability, Customized design, Lower energy consumption & Lower installed costs. Our products are well tested for performance as per the design condition for longevity, sustainability and durability.

* AHU - CEILING SUSPENDED UNIT

CAPACITY RANGE » 800 to 12000 CFM

APPLICATIONS » Comfort Air-Conditioning For Shopping Malls, Multiplexes, Small offices

FEATURES » Compact, low height, with single / Twin centrifugal fan

CEILING SUSPENDED DUCTABLE UNITS

Model	Air Volume CFM	Fan Model	Fan Outlet Velocity (M/s)	Coil Area (Sq./Fc)	RPM/MOr KW at a Static Pressure		Orsial Dimensions		
					30mTIW\$	40ffllTIW\$	Dg\$th	Width	H5ight
ZS-CS-12	1200	9x9x1	7.3	2.4	1166/0.37	1368/0.75	900	900	550+50
ZS-CS-15	1500	9x9x1	9.1	3	1152/0.75	1338/0.75	900	940	550+50
ZS-CS-20	2000	10x10X1	9.9	4	1017/0.75	1177/1.1	950	1040	610+50
ZS-CS-25	2500	12X12X1	8.8	5	872/0.75	1021/1.1	1010	1116	670+50
ZS-CS-30	3000	9x9x2	9.1	6	1210/1.1	1405/1.5	900	1563	550+50
ZS-CS-35	3500	10x10x2	8.6	7	1070/1.1	1246/1.5	950	1588	610+50
ZS-CS-40	4000	10x10X2	9.9	8	1068/1.5	1236/2.2	950	1778	610+50
ZS-CS-45	4500	12X12X2	7.9	9	925/1.5	1085/2.2	1010	1778	610+50
ZS-CS-50	5000	12x12X2	8.8	10	916/1.5	1072/2.2	1010	1930	670+50
ZS-CS-55	5500	12x12x2	9.6	11	911/2.2	1062/2.2	1010	2096	670+50
ZS-CS-60	6000	12x12X2	10.5	12	911/2.2	1055/3.7	1010	2260	670+50
ZS-CS-70	7000	15X15X2	8.7	14	765/2.2	893/3.7	1200	2353	760+50
ZS-CS-80	8000	15x15X2	9.9	16	765/3.7	884/3.7	1200	2440	800+50
ZS-CS-90	9000	18x1X8X2	8	18	643/3.7	748/3.7	1250	2502	900+50
ZS-CS-100	10000	18x18x2	8.9	20	641/3.7	743/5.5	1250	2743	900+50
ZS-CS-110	11000	18x18x2	9.7	22	642/3.7	741/5.5	1250	2880	960+50
ZS-CS-120	12000	18x18x2	10.6	24	646/5.5	741/5.5	1300	3006	960+50

Above technical details refer to a static pressure of 8-10 mm WG Standard Models with 25 mm thick panels.
For more details please contact our technical assistance department. All dimensions are in mm



" HORIZONTAL FLOORMOUNTED AIR HANDLING UNIT

CAPACITY RANGE 1000 to 40000 CFM
 APPLICATIONS Comfort Air Conditioning for Schools, Multiplexes, Hotels, Operation Theater/ICb/ICC LI, Pharma, Laboratories & Clean Room Application
 FEATLIRES The Lnit is manufactured as per the customer's requirements.

Model	CFM	Fan Model	Fan Outlet Velocity (m/s)	Coil Area (Sq./Ft.)	RPM/Motor KW at a Static Pressure		Overall Dimensions		
					40mm	50mm	Length	Width	Height
ZS-FMU-15	1500	9x9x1	9.1	30	1338/0.75	1511/0.75	1310	850	830
ZS-FMU-20	2000	10/10x1	9.9	4.0	1177/0.75	1325/1.1	1360	950	850
ZS-FMU-25	2500	12/12x1	88	5.0	1021/1.1	1156/1.5	1440	1120	850
ZS-FMU-30	3000	15x15x1	10.5	6.0	1005/1.1	974/1.5	J440	1200	880
ZIFMUMO	4000	45x450	9.9	80	842/1.5	949/2.2	1530	1370	950
ZS-FMU-45	4500	18x18x1	8.0	9.0	713/2.2	804/2.2	1670	1630	1050
ZS-FMU-50	5000	18x18x1	89	JO.0	708/2.2	797/2.2	1670	1640	1050
ZS-FMU-60	6000	450x1	87	12.0	724/3.7	821/3.7	J800	1560	1200
ZS-FMU-65	6500	450x1	9.5	13.0	718/3.7	812/3.7	1800	1665	1200
ZS-FMU-75	7500	500x1	8.7	15.0	659/3.7	741/3.7	1925	1680	1275
ZS-FMU-80	8000	500x1	9.3	J6.0	658/3.7	738/5.5	1925	1950	1275
ZS-FMU-90	9000	560x1	8.3	18.0	586/3.7	661/5.5	2050	1780	1500
ZS-FMU-100	10000	560x1	9.2	20.0	584/3.7	656/5.5	2050	780	1500
iS-FMU-110	11000	560x1	10.2	22.0	584/5.5	653/5.5	2050	2100	1500
iS-FMU-120	12000	630x1	88	24.0	511/5.5	fi77/7.5	2220	2060	1600
ZS-FMU-130	13000	630x1	96	26.0	508/5.5	fi73/7.5	2270	2300	1600
ZS-FMU-140	14000	710x1	8.2	28.0	459/5.5	516/7.5	2450	2100	1850
iS-FMU-150	15000	710x1	8.8	30.0	457/5.5	514/7.5	2450	2150	1850
iS-FMU-160	16000	710x1	9.4	32.0	457/7.5	512/7.5	2450	2350	1850
iS-FMU-180	18000	800x1	8.4	36.0	399/7.5	448/9.3	2650	2350	2J50
ZS-FMU-200	20000	800x1	9.3	40.0	398/7.5	446/9.3	2650	2560	2150
ZS-FMU-220	22000	800x1	10.2	44.0	399/9.3	445/11.0	2650	2800	2150
ZS-FMU-240	24000	900x1	8.9	48.0	360/9.3	406/15.0	2780	2900	2200
iS-FMU-250	25000	900x1	9.2	50.0	359/11.0	405/15.0	2780	3050	2200
ZS-FMU-280	28000	1000x1	8.2	56.0	322/11.0	365/15.0	3110	3110	2500
ZS-FMU-300	30000	1000x1	8.8	60.0	320/11.0	362/15.0	3110	3260	2350
ZS-FMU-320	32000	1000x1	9.4	64.0	319/15.0	360/15.0	3110	3260	2500
iS-FMU-350	35000	1000x1	10.3	70.0	318/15.0	357/18.5	3110	3360	2810

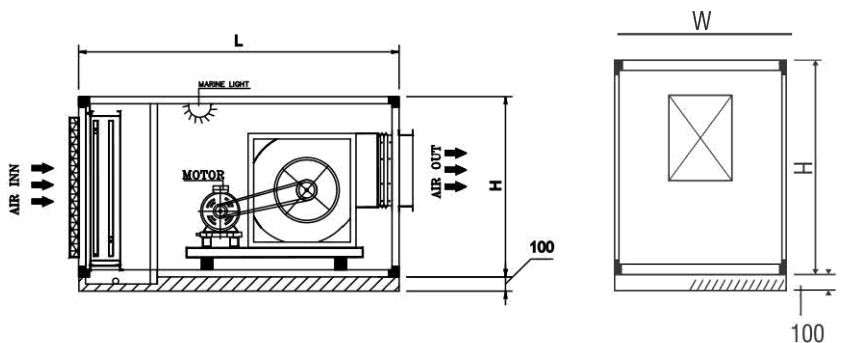

OPTIONS : Single/Double Tier Construction

- » Thermal break profile with 25/43/50mm panel Sickness
- » Fiter sectors for EU-5, EU-7, EU-13 in Rigid/Bag construction
- Heat recovery Wheel/Heat Pipe | Humidification, Pre/ Reheat Package
- » Mixing Box with Fresf/Return Air Dampers
- Weatherproof Light, Limit switch, View glass
- « • • ^ I VFD Drive

Mixing Section With PRE filter	Chilled Water Coil Section 1-6 Rows Deep	Hot Water Coil Section 1-2 Rows Deep	Electric heater Section	Discharge Plenum with Fine Filter	Discharge Plenum with HEPA Filter	Fiber Quantity 1 / 2 / 3
500	450	200	200	1400	875	1/0/0
500	450	200	200	400	875	1/0/0
500	450	200	200	1400	875	1/1/0
500	450	200	200	1400	875	1/1/0
500	450	200	200	1400	875	2/0/0
500	450	200	200	1400	875	2/1/0
500	450	200	200	1400	875	2/1/0
550	450	200	200	1400	875	2/2/0
550	450	200	200	1400	875	2/3/1
550	450	200	200	1400	875	2/3/1
550	450	200	200	1400	875	3/3/0
550	450	200	200	1400	875	4/2/0
550	450	200	200	1400	875	4/2/0
550	450	200	200	1400	875	6/0/0
550	550	200	200	1400	875	6/0/0
550	550	200	200	1400	875	6/5/0
550	550	200	200	1400	875	6/3/0
600	550	200	200	1400	875	6/3/0
600	550	200	200	1400	875	6/5/1
600	550	200	200	1400	875	6/5/1
600	550	200	200	1400	875	9/3/0
600	550	200	200	1400	875	12/0/0
600	550	200	200	1400	875	12/0/0
600	550	200	200	1400	875	12/3/0
600	550	200	200	1400	875	12/4/0
600	550	200	200	1400	875	15/0/0
600	550	200	200	1400	875	15/5/0
600	550	200	200	1400	875	20/0/0

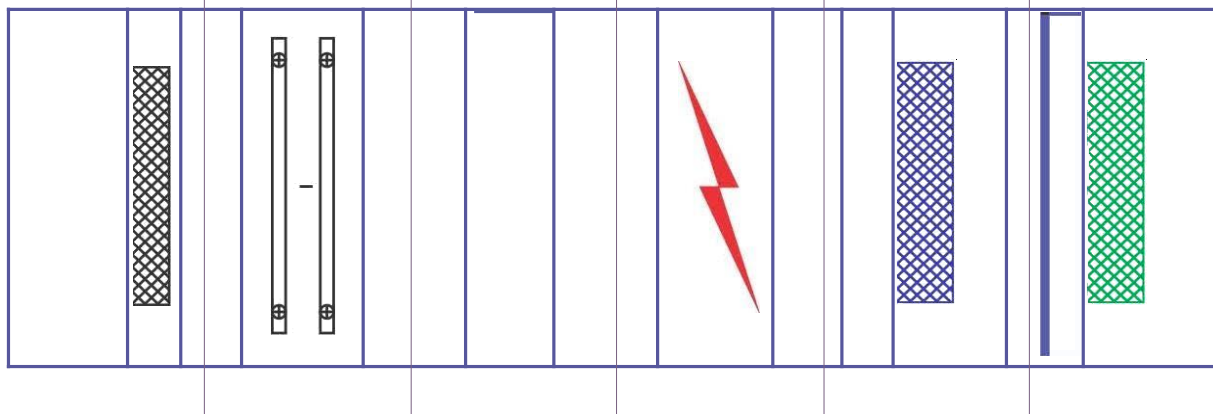

FILTER SIZES
 1 - 610x610
 2 - 610x305
 3 - 305x305

^ AIR HANDLING UNIT WITH HEAT RECOVERY WHEEL

CAPACITY RANGE › 1000 to 30000 Cfm

APPLICATIONS › Operation Theater/ICLI/CCU, Pharma, Laboratories & Clean room Application

FEATURES › The Unit is manufactured as per the customers requirements.
Thermal break profile with 25/43/50mm panel thickness

OPTIONS › Filter sections for EU-5, EU-7, in Rigid/Bag construction
› Heat recovery Wheel/Heat Pipe | Humidification, Pre/ Reheat Package
› Mixing Box with Fresh/Return Air Dampers
› Weatherproof Light, Limit switch, View glass
› Plug Fan | VFD Drive

Model	CFM	HRW DIA	Fan Model	Coil Area (Sq./Ft.)	Overall Dimensions		
					Height	Width	Plenum L1
ZS-HRU-10	1000	700	225	2.0	1700	1100	850
ZS-HRU-12	1200	700	225	2.4	1800	J 200	850
ZS-HRU-15	1500	800	225	3.0	1800	1200	850
ZS-HRU-20	2000	900	250	4.0	1900	1400	900
ZS-HRU-25	2500	1000	250	5.0	2100	1450	900
ZS-HRU-30	3000	1100	315	6.0	2100	500	900
ZS-HRU-40	400	1200	355	8.0	2300	1700	1000
ZS-HRU-45	4500	1300	355	9.0	2500	1800	1000
ZS-HRU-50	5000	1400	400	10.0	2500	1925	1J 50
ZS-HRU-60	6000	1500	450	12.0	2700	2025	1250
ZS-HRU-70	7000	1600	450	14.0	2900	2125	1250
ZS-HRU-75	7500	1700	450	15.0	2900	2175	1250
ZS-HRU-80	8000	1700	500	16.0	3300	2225	1350
ZS-HRU-85	8500	1800	500	17.0	3300	2275	1350
ZS-HRU-90	9000	1800	500	18.0	3300	2375	1350
ZS-HRU-95	9500	1900	560	19.0	3300	2375	1450
ZS-HRU-100	10000	2000	560	20.0	3500	2425	1450
ZS-HRU-J 20	12000	2200	630	24.0	3500	2425	1550
ZS-HRU-130	13000	2200	630	26.0	3500	2500	1550
ZS-HRU-150	15000	2400	710	30.0	3900	2625	1725
ZS-HRU-180	18000	2600	710	36.0	3900	2775	1725
ZS-HRU-200	20000	2800	800	40.0	4100	2975	1850
ZS-HRU-250	25000	3000	900	50.0	5000	3175	2050

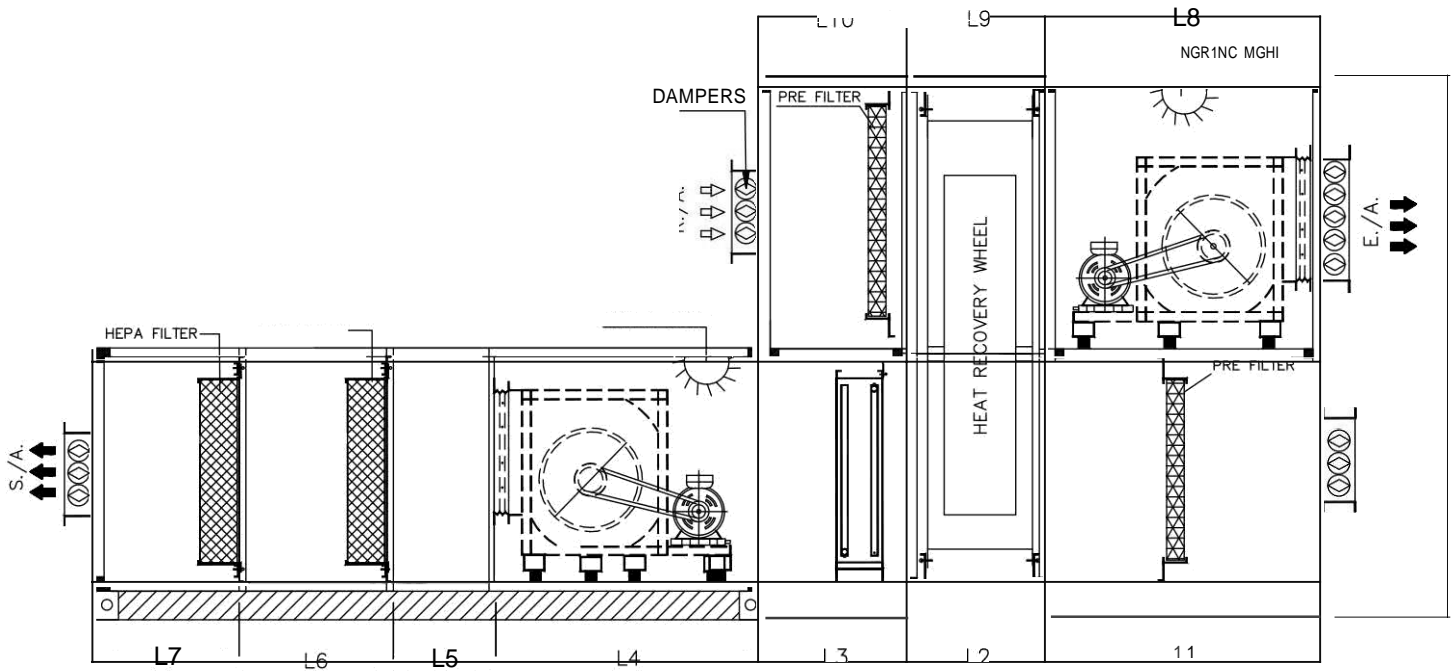

Overall Dimensions

HRW L2	CWC L3	SA FAN L4	IV LS	HF L6	PLENUM L7	EA FAN L8	HRW L9	PLENUM L10
500	450	850	875	875	550	850	500	550
500	450	850	875	875	550	850	500	550
500	450	850	875	875	550	850	500	550
500	450	900	875	875	550	900	500	550
500	450	900	875	875	550	900	500	550
500	450	900	875	875	550	900	500	550
500	450	1000	875	875	550	1000	500	550
500	450	1000	875	875	550	1000	500	550
500	450	1150	875	875	550	1150	500	550
500	450	1250	875	875	550	1250	500	550
500	450	1250	875	875	550	1250	500	550
500	450	1250	875	875	550	1250	500	550
500	450	1350	875	875	550	1350	500	550
500	450	1350	875	875	550	1350	500	550
650	450	1350	875	875	550	1350	650	550
650	450	1450	875	875	550	1450	650	SS0
650	450	1450	875	875	550	1450	650	550
650	450	1550	875	875	550	1550	650	550
650	550	1550	875	875	550	1550	650	550
650	550	1725	875	875	550	1725	650	550
650	550	1725	875	875	550	1725	650	550
650	550	1850	875	875	550	1850	650	550
650	550	2050	875	875	550	2050	650	550

UNITARY/VERTICAL UNITS

CAPACITY RANGE » 1000 to 18000 CFM

APPLICATIONS » Comfort Air Conditioning-For Shopping Malls, Multiplexes , Small Offices & Hotels

FEATURES » Customized Units available for space saving uq to 18000 CFM

OPTIONS » Belt driyen units available in Double/Single Skin with Single/M lti Centrifugal Fan

Model	Air Volume CFM	Fan Model	Fan Outlet Velocity (M/s)	Coil Area (Sq./Ft.)	Overall Dimensions			RPM/Motor M at a Static Pressure		
					Depth	Width	Height	30mm wg	40mm Wg	50mm WG
ZS-VG-12	1200	9x9x1	7.3	2.4	630	925	1150	1166/0.5	1368/0.75	1550/0.75
ZS-VU-15	1500	9x9x1	9.1	3.0	630	1050	1200	1152/0.5	1338/0.75	1511/0.75
ZS-VU-20	2000	10x10x1	9.9	4.0	670	1050	1350	1017/0.75	1177/0.75	1325/1.1
ZS-VU-25	2500	12x12x1	8.8	5.0	740	1225	1450	872/0.75	1021/1.1	1156/1.5
ZS-VG-30	3000	9x9x2	9.1	6.0	630	1540	1250	1210/0.75	1405/1.5	1586/1.5
ZS-VU-40	4000	10x10x2	9.9	8.0	670	1750	1350	1068/1.5	1236/2.2	1391/2.2
ZS-VU-50	5000	12x12x2	8.7	10.0	740	1960	1450	916/1.5	1072/2.2	1213/3.7
ZS-VU-60	6000	12x12x2	10.5	12.0	740	2060	1550	911/2.2	1055/3.7	1190/3.7
ZS-VG-70	7000	15x15x2	8.7	14.0	830	2160	1825	765/2.2	893/3.7	1009/3.7
ZS-VU-80	8000	15x15x2	9.9	16.0	830	2210	1850	765/3.7	884/3.7	996/5.5
ZS-VU-100	1000	18x18x2	8.9	20.0	990	2560	1950	641/3.7	743/5.5	837/5.5
ZS-VU-120	12000	18x18x2	10.6	24.0	990	2825	2025	646/5.5	741/5.5	829/7.5
ZSVU-140	14000	450x2	10.2	28.0	1080	2625	2480	622/2.2X2	715/3.7x2	806/1.07x2
ZS-VU-160	16000	500x2	9.3	32.0	1230	3025	2580	572/3.7x2	658/3.7x2	738/5.5X2
ZS-VU-180	18000	500x2	10.4	36.0	1200	3025	2680	580/3.7X2	660/3.7x2	736/5.5X2



^ SINGLE & DOUBLE SKIN CEILING FAN COIL UNIT

CAPACITY RANGE » 400 CFM (1 TR) to 1200 CFM (3 TR)

TYPES » Chilled Water / Direct Expansion

APPLICATIONS » Comfort Air Conditioning for Hotel, Hospitals, offices, Class rooms, SMdio, Shopping Malls

FEATLRES » Casing Made out of Pre coated/Galvanized/Power coated sheets
Sandwiched insulated drain pan with expanded polystyrene
Vibration free, noise less, single phase direct dryen motor with

OPTIONS Tree way Mixing/Diverting Valves
Ball Valve set

Unite Model		2S-C FCU-4	2S-C FCU-6	2S-C FCU-8	7S-C FCU-10	7S-C FCU-12	
	Nominal Air Flow	CFM	400	600	800	1000	1200
	Nominal Cooling Capacity	Btu/Hr.	12200	19000	25893	32350	39400
		Tons	1.0TR	1.5TR	2.0TR	2.5TR	3.0TR
Power Supply	Type	Centrifugal Forward CU/fpg, DIDW					
	Qty	Nos	2	2	2	2	2
Motor		V/Pfi/Hz.	230/1/50				
	Power (For Normal Static)	Hp	1/20	1/12	1/12	1/12	1/4
Motor	RPM/Speed		930/3	930/3	930/3	920/3	920/3
	Power (For High Static)	Hp	1/5	1/5	1/5	1/4	1/3
	RPM/Speed		1200/2	1200/2	930/3	1200/2	1200/2
	Qty	Nos	1	1	1	1	1
	Tube Material		Copper Tube				
	Tube O.D.	mm	952				
	Min Material		Aluminium				
	Rows Deep		3				
Air Filter	Face Area	Sq. ft	1.33	1.77	2.43	3	3.5
			12mm Thick Rough Filters, Washable Type				
Overall Dimension	Height	mm	256	256	305	356	356
	Width	mm	950	1118	1193	1219	1371
	Depth	mm	676	576	598	598	653
OperationWt		kg	35M3	39	44	48	66

Nominal Cooling Capacities are based on 80°F (DB)& 67°F (WB) Air Entering Temperature, 45°F & 53°F Water Inlet/outlet Temperatures



^ AIR WASHER

CAPACITY RANGE » 1000 CFM upto 100000 CFM

TYPES » Pad Type Airwasher

APPLICATIONS » Hotel, Hospital, Industry, Colleges, Theater

FEATURES Fill Type system can attain very high saturation efficiencies as against conventional system. Power consumption negligible as compared to spray machine due to low pump power and low pressure drop. Quick installation as machine is factory fabricated and tested and has flexibility in regard to re-ovation at a later date. Compact pre-fabricated design to take less space, consuming only 40% of conventional systems. Power consumption negligible as compared to spray machine due to low pump power and low pressure drop. Quick installation as machine is factory fabricated and tested and has flexibility in regard to re-location at a later date.

OPTIONS » Double/Single skin, Masonry type, Water Tank in Stainless Steel-202/304, Cooling Pad 200/300mm PVC Eliminator Water Pump, Intake louvers & bird screen

Model	CFM	Fan Model	Pressure (Sq/Ft)	RPM/Motor KW at a Static Pressure		Overall Dimensions		
				40mm	50mm	D9gth	Width	Height
ZS-AW-30	3000	5x1	6.00	1005/1.1	974/1.5	1690	1100	970 + 100
ZS-AW-50	5000	18x1	10.00	708/2.2	797/2.2	1920	1700	970 +100
ZS-AW-60	6000	450x1	12.00	724/3.7	821/3.7	2090	1400	1290+100
ZS-AW-80	8000	50x1	16.00	658/3.7	738/5.5	2300	1800	1290+100
ZS-AW-100	10000	560x1	20.00	584/3.7	656/5.5	2300	1700	1590+100
ZS-AW-120	12000	630x1	24.00	511/5.5	577/7.5	2470	2000	1590 +100
ZS-AW-140	14000	710x1	28.00	459/5.5	516/7.5	2600	1990	1890+100
ZS-AW-150	15000	710x1	30.00	457/5.5	514/7.5	2600	2000	1890+100
ZS-AW-160	16000	710x1	32.00	457/7.5	512/7.5	2600	2130	1890+100
ZS-AW-180	18000	800x1	36.00	399/7.5	448/9.3	2900	2400	1890 +100
ZS-AW-200	20000	800x1	40.00	398/7.5	446/9.3	2900	2620	1890+100
ZS-AW-220	22000	800x1	44.00	399/9.3	445/11	2900	2870	1890+100
ZS-AW-240	24000	900x1	48.00	360/9.3	406/15	3100	2640	2200+100
ZS-AW-250	25000	900x1	50.00	359/11.0	405/15	3100	2750	2200 +100
ZS-AW-280	28000	1000x1	56.00	322/11.0	365/15	3300	3090	2240+100
ZS-AW-300	30000	1000x1	60.00	320/11.0	362/15	3300	3300	2240+100
ZS-AW-320	32000	1000x1	64.00	319/15.0	360/15	3300	3500	2240+100
ZS-AW-350	35000	1000x1	70.00	318/15.0	357/18.5	3300	3810	2240 +100
ZS-AW-400	40000	800x2	80.00	398/7.5 X 2	446/9.3 X 2	2940	5160	1920+100
ZS-AW-450	45000	800x2	90.00	399/9.3 X 2	445/11 X 2	2940	4850	2240+100
ZS-AW-500	50000	900x2	100.00	359/11.0 X 2	405/15 X 2	3100	5400	2240+100
ZS-AW-600	60000	1000x2	120.00	320/11.0 X 2	362/15X2	3300	4850	2810 +100

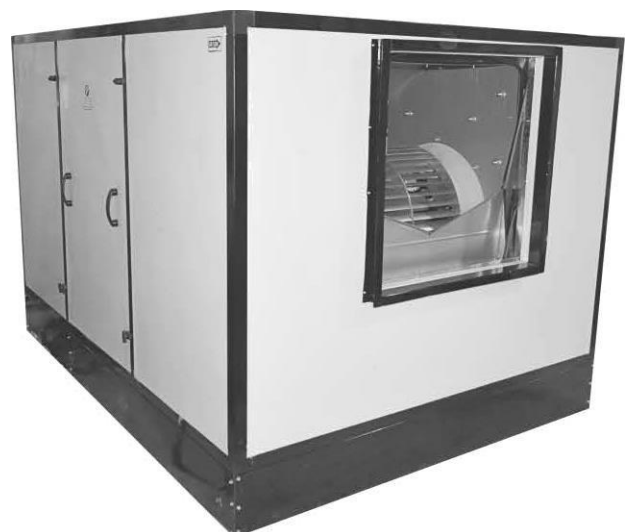
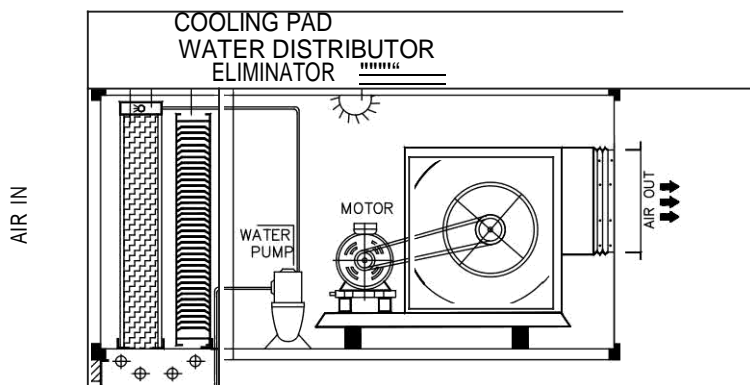

^ AIR SCRUBBER

CAPACITY RANGE » 10000 CFM up to 100000 CFM

TYPES » Wet Type / Dry Type

APPLICATIONS » Hospital, Hotel Kitchen, College, Industry and other

FEATURES » Corrosion resistant AMCA rated fan on the inlet or outlet side of the scrubber. Corrosion resistant recirculating pumps for scrubber liquid recirculation fan-plugging spray nozzles for wetting packing in a wide range of corrosion resistant materials. Moisture eliminators with chevron, mist pad or loose fill type designs

OPTIONS » Double / Single Skin
 Water Tank in Stainless Steel 202/304
 Eliminator section, PVC /GI Eliminators
 Backward corvtd blower
 Double bank filter section
 Single / Double bank spray chamber

Model	CFM	Fan Model	Elimator Area (Sq./Ft.)	RPM/Motor M at a Static Pressure		Overall Dimensions		
				60mm	80mm	Length	wiatr	Height
ZS-AS-30	3000	315x1	6.00	1243/2.2	2429/2.2	2800	1070	960 + 100
ZSAS#0	4000	355x1	8.00	1J 08/3.7	2174/3.7	2850	1380	960 +100
ZS-AS-50	5000	400x1	10.00	990/3.7	1930/3.7	3000	1680	960 + 100
ZS-AS-60	600D	450x1	12.00	911/5.5	1672/3.7	3150	1380	1260 +100
ZS-AS-80	8000	500x1	16.00	813/5.5	1532/5.5	3250	1780	1260+ 100
ZS-AS-100	10000	560x1	20.00	723/7.5	1359/7.5	3400	1680	1560+100
ZS-AS-120	12000	630x1	24.00	638/7.5	1177/7.5	3550	1990	1560+100
ZS-AS-150	15000	710x1	30.00	566/9.3	1037/9.3	3800	1990	1860 +100
ZS-AS-180	18000	710x1	36.00	561/11.0	1103/11.0	4000	2380	1860+ 100
ZS-AS-200	20000	800x1	40.00	491/11.0	939/11.0	4000	2610	1860+100
ZS-AS-220	22000	800x1	44.00	488/15.0	969/15.0	4000	286	1860+100
ZS-AS-250	25000	900x1	50.00	447/15.0	836/15.0	4150	2780	2200 +100
ZS-AS-2B0	28000	900x1	56.00	443/18.5	869/18.5	4450	3090	2200+100
ZS-AS-300	30000	1000x1	60.00	401/18.5	749/18.5	4450	3290	2200+100
ZS-AS-350	35000	1000x1	70.00	394/18.5	788/22.0	4450	3810	2200+100
ZS-AS-400	40000	800x2	80.00	491/11.0 X 2	939/11.0 X 2	t000	5090	1860 +100
ZS-AS-450	45000	800x2	90.00	488/15.0 X 2	977/15.0 X 2	4000	4850	2200+100
ZS-AS-500	50000	900x2	100.00	447/15.0 X 2	836/15.0 X 2	4150	5400	2200+100

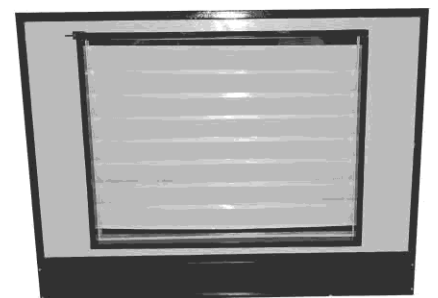
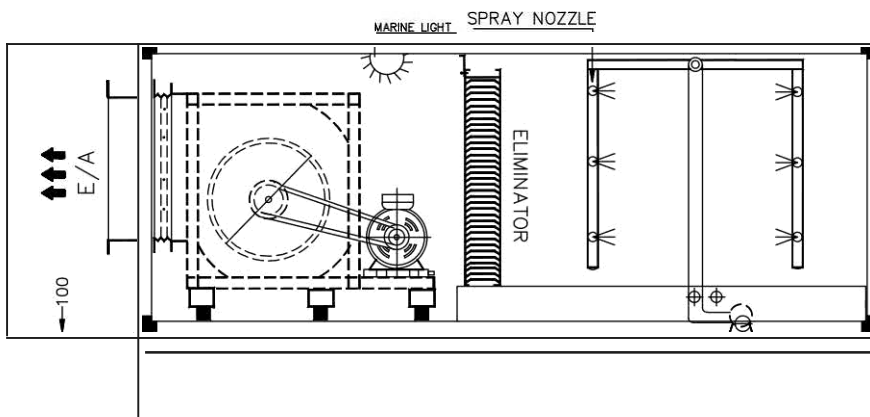

* FRESH AIR UNIT

- CAPACITY RANGE » 1000 CFM to 100000 CFM
- TYPES » Coiling Type Floor Mounted
- APPLICATIONS » Hospital, Hotel, Colleges and many other uses
- FEATURES
Highly suitable for fresh air
Specially designed for pharmaceutical
Available with pre-filters
- OPTIONS
» Cowl
Fine Filters
Hepa Filters
Dampers

Model	Air Volume CFM	Fan Model	Fan Outlet Velocity (M/s)	Filter Area (Sq./Ft.)	RPM/Motor KVY at a Static Pressure		Overall Dimensions		
					30mm	40mm	Length	Width	Height
ZS-FAU-12	1200	9x9x1	7.3	2.0	1166/0.37	1368/0.75	940	760	650+100
zS-FAU-15	1500	9x9x1	9.1	4.0	1152/0.75	1338/0.75	890	760	650+100
ZS-FAU-20	2000	10x10x1	9.9	4.0	1017/0.75	1177/0.75	990	900	670+100
ZS-FAU-25	2500	12x12x1	8.8	4.0	872/0.75	1021/1.1	1000	950	725+100
ZS-FAU-30	3000	15x15x1	7.4	6.0	737/1.1	863/1.1	1150	1100	825+100
zS-FAU-40	4000	15x1x51	9.9	6.0	728/1.1	842/1.5	1150	1100	825+100
ZS-FAU-60	6000	450x1	9.5	8.0	620/2.2	724/3.7	1400	1285	1050+100
ZS-FAU-80	8000	500x1	9.3	12.0	572/3.7	658/3.7	1480	1400	1125+100
ZS-FAU-100	10000	560x1	9.2	16.0	507/3.7	584/3.7	1550	1400	1260+100
ZS-FAU-120	12000	630x1	8.8	16.0	439/3.7	511/5.5	1680	1550	1450+100
ZS-FAU-160	16000	710x1	9.4	20.0	397/5.5	457/7.5	1980	1700	1600+100
ZS-FAU-200	20000	800x1	9.3	30.0	346/7.4	398/7.5	2125	1900	1750+100
ZS-FAU-250	25000	900x1	9.2	36.0	310/7.4	359/11.1	2360	2100	2000+100
ZS-FAU-300	30000	1000x1	8.8	42.0	275/9.2	320/11.1	2550	2400	2100+100
ZS-FAU-350	35000	1000x1	10.3	48.0	276/11.1	318/15.0	2550	2400	2100+100

All dimension unless otherwise specified are in mm.

Due to continuous improvement the dimensions are subject to change without one prior notice



" AIR EXHAUST

CAPACITY RANGE » 1000 CFM to 100000 CRM

TYPES Ceiling Suspended
Floor Mounted

APPLICATIONS Hospkal, Hotel Kitchens, Colleges and many other uses application

FEATURES Highly suitable for the exhaust
Specially designed for pharmaceutical

OPTIONS » Cowl
Dampers

Model	Air Volume (CFM)	Fan Model	Fan Outlet Velocity (M/s)	RPM/Motor KW at a Static Pressure		Overall Dimensions		
				40mm	50mm	Length	Width	Height
ZS-EAU-12	1200	9"91	7.3	1368/0.75	1550/0.75	940	760	650 + 100
ZS-EAU-15	1500	9"9"1	9.1	1338/0.75	1511/0.75	890	760	650 +100
ZS-EAU-20	2000	10"J 0"1	9.9	1177/0.75	1325/1.1	990	900	670 + 100
ZS-EAU-25	2500	12"12"1	8.8	1021/1.1	1156/1.1	1000	950	725 + 100
ZS-EAU-30	3000	15x15x1	7.4	863/1.1	974/1.5	1150	1100	825 + 100
ZS-EAU-40	4000	15x15x1	9.9	842/1.5	949/2.2	1150	1100	825 +100
ZS-EAU-60	6000	450x1	9.5	724/3.7	821/3.7	1400	1285	1050 + 100
ZS-EAU-80	8000	500x1	9.3	658/3.7	738/5.5	1480	1400	1125 + 100
ZS-EAU-100	10000	560x1	9.2	584/3.7	656/5.5	1550	1400	1260+100
ZS-EAU-120	12000	630x1	8.8	511/5.5	577/7.5	1680	1550	1450 +100
ZS-EAU-160	16000	710x1	9.4	457/7.5	512/7.5	1980	1700	1600 + 100
ZS-EAU-200	20000	800x1	9.3	398/7.5	446/9.3	2125	1900	1750+100
ZS-EAU-250	25000	900x1	9.2	359/11.1	405/15	2360	2100	2000+100
ZS-EAU-300	30000	1000x1	8.8	320/11.1	362/15	2550	2400	2100 +100
ZS-EAU-350	35000	1000x1	0.3	318/15.0	357/18.5	2550	2400	2100 + 100

All dim custom unless otherwise specified ate in mm

Due to contiuous improvement the dimensions ore subject to cha nge without one prior notice



^ AXIAL FLOW FANS

Vistaar, Axial Flow fans are designed for air ventilation in commercial or industrial building and are available from 315 mm dia to 1800 mm dia that covers the CFM up to 100000. The blade pitch is field adjustable to accommodate system changes. The casing design and construction are well suited for indoor or outdoor applications and can be easily installed in ducted or non-ducted systems. Fans & blades are designed to reduce operating cost with improved efficiency design offers inherently lower sound level than other axial fans.

Types

Axial flow fan (Normal Series)
Axial flow fan (High Temp. Series for 250 & 300 up to 2 hrs)

Options

Pedestal Stand
Bird Screen
Sound Attenuator

Application

General Ventilation
Emergency Smoke and Heat Exhaust
Car Ventilation / Basement
Stairwell pressurization

Construction

Fan casing is made of heavy gauge M.S. Sheet. It has flanges at both ends for easy fixing. Impellers are made of Die cast aluminium having Aerofoil design with adjustable pitch angle. Maintenance free reliable IEC motors.



COILS

We Manufacture Coils in 1/2 & 3/8 for the commercial and industrial applications. These coils can be made from 2 row to 12 row deep.

We, Plays a very important role in procurement of copper tube and aluminium foil from across the globe to maintain the international standard.

Features:

- Aluminum foils with or without hydrophilic coating
- End plate stainless steel/Galvanized iron
- Dimensions accuracy

- Direct Expansion
- Chilled Water
- Heating

Options:

- Copper header
- Inter-Mined coil



HEPA FILTERS

The standard HEPA Filters enables better than Class 100 conditions. These filters can be directly installed in AHUs or mounted in banks in separate single skin plenums. Following are the construction features of our range:

- Efficiency 95 down to 0.5 µ
- Filter media synthetic non-woven deep pleated
- Frame material: Aluminum/GI/SS/MS
- Frame type box / Flange

FILE FILTERS

Are widely used in pharmaceutical, clean room, semi-conductor biotechnology, photo film, optical, precision, mechanical, critical, O.T., defense, air handling units and air conditioning etc as secondary or final filter. These filters are resistant to chemicals & organic solvents. Following are the construction features of our range:

- Efficiency 90 down to 10 µ
- Efficiency 90 down to 20 µ
- Filter media synthetic non-woven /Al wiremesh
- Frame material:
 - Thickness available: 25mm/50mm

PRE FILTERS

Are widely used in air conditioning, Air Handling Units, pharmaceutical, clean room, semi-conductor biotechnology, photo film, optical, precision mechanical, critical O.T., defense etc as Pre Filter and riser filters. following are the construction features of our range:

- Efficiency 90 down to 10 µ
- Efficiency 90 down to 20 µ
- Filter media synthetic non-woven /Al wiremesh
- Frame material: Aluminum/GI
- Thickness available: 25mm/50mm

FILTERS



^ ACCESSORIES

Accessories are the most important parts in any product it can change look & finishing quality of products. Zonex takes the responsibility to use suitable genuine accessories placed in different machines & keep on upgrading all accessories through continuous improvement which makes our Products different from others. We can also provide customized accessories as per the needs.



FRAMEWORK

Corrosion resistant aluminum profile with specially designed 3-way corners. (Thermal break on demand)

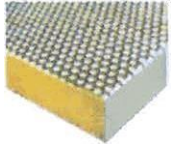

FRAME PANELS

Double skin sandwich panels fabricated from inside with 0.63mm (24 G) galvanvanized sheet steel and outside with 0.63mm (24 G) pre-coated galvanvanized sheet steel. The panels have infilled insulation of 40 Kg/m³ density puf injection/pufslab, resulting in high rigidity and sound attenuation characteristics.

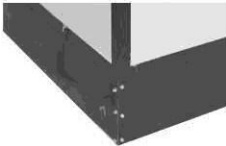

BASE FRAME

Base frame is made of galvanvanized steel with die cast aluminum joints having lifting holes.



CONDENSATE DRAIN PAN

Drain pan can be made of aluminium/ G.I / S.S with dual slope to facilitate immediate discharge of condensate. Specially designed drain pan with all rounded edges allow complete cleaning and avoid microbial growth.



FAN SECTION

Nicotra or Kruger centrifugal fans are used either SISW or DIDW type with forward curve or backward curved driven with belts as per static pressure requirements.



CELDEK PAD

Cellulose pad is used in evaporative cooling unit. It is cross corrugated coated with anti rot, rigidifying & wetting resins makes the material stiff and self supporting.



INSPECTION GLASS

Port Hole Used In Air Handling Unit Sight Window For Checking Operation In Machine.



HINGES & LOCKS

Access doors are provided with hinges and locks made of self-extinguishing nylon for perfect air tightness.

^ CLIENTS

airtel



CROWNE PLAZA



H&M



P SM

c9berc 9



IRCTC



The Great India Place

TITAN



BENTLEY



Panasonic

RELIGARE



Dominé'u



RANBAXY





VISTAAR ENTERPRISES

Head Office: New Delhi

Branch Office: Mumbai

Mobile: +91-8929920007

Email:

reachvistaar@gmail.com

Website:

www.vistaarenterprises.com

H.O:- 362/A-2, SATAYAMPURAM, JHARODA
BORDER, NEAR ASHRAM, NEW DELHI-72

