

WHALE | GRABS

**THE
STRONGARM
MOVER**

*Compact
Lifting and Disposal
Unit*

Reliability, Service, Value ... for Life



WHALE GRABS SPECIFICATION

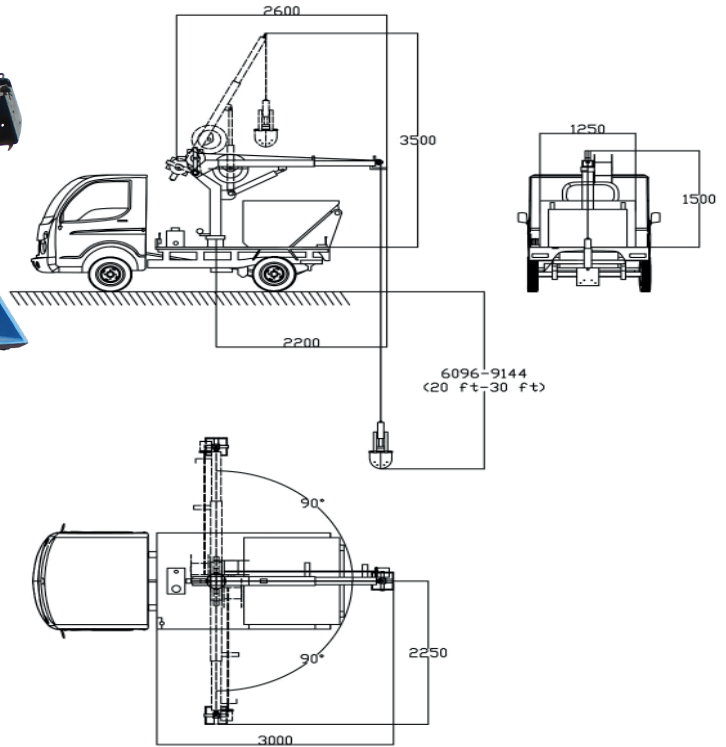

Whale Grabs is specially designed for cleaning silt and waste from manholes, open ditches ...etc without human touch, It is mounted on a low wheel base vehicle that has a short turning radius useful for narrow lanes, equipment consists of a grab bucket and winch arrangement to grab silt from deep manholes and store in the rear hopper. The collected silt is transported to disposal sites and emptied by rear tipping.

All functions are performed by manual hydraulic valve. Remote control is optional. It delivers a faster more economical operation with no human touch and no life risk.

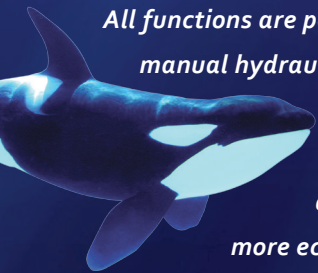

Description

Detail

GVW	1500 - 2000 Kg
Manhole Size Range	0.9 - 1.5 M
Rear Hopper	0.35m ³
Lifting Capacity	50 Kg
Bucket Operating System	Hydraulic
Boom	Manuall or Hydraulic (optional) extensible type of 45° Lifting angle and swivelling through 180°
Controls	Manually Operated Hydraulic valves or Electro Hydraulics through Remote (Optional)
Winch Drive Arrangement	Worm Gear Box drive by Hydraulic Motor
Lifting Length	20 -30 Feet
Tipping Angle	80-90°

Reliability, Service, Value ... for Life

1/1D Vilankurichi Road, Near Senthottam ,
Kalapatti, Coimbatore - 641 048, Tamilnadu, India
Telephone: +91 95009 45511
sales@whaleenterprise.in www.whaleenterprise.in