



AN ISO 9001:2015 CERTIFIED COMPANY



RING BLOWERS

RING TURBINE / REGENERATIVE / SIDE CHANNEL BLOWERS

ABOUT US

With the expertise earned from 45+ years of experience, AKASH started manufacturing of Twin Lobe Rotary Air Blowers wayback in 2009. Since then the company has consistently strengthened its manufacturing base producing a wide range of products line includes TWIN LOBE & TRI LOBE ROTARY Air Blowers/Compressors (Root Blowers), Mechanical Vacuum Boosters & Acoustic Hoods. We have also started dealing and manufacturing in Ring Blowers/Regenerative/Side Channel Blowers and Volute Dewatering Machine. These wide-range products and the technical expertise gained over the year have enabled AKASH to serve various segments of industry- such as Flue Gas Application in sponge Iron, Silo Aeration for Cement Plants, Bulke unloading, Pneumatic conveying Sulphonation in Sugar plants, Water treatments plants, Effluent treatment plants, Aqua culture farms, Chemical & pharmaceutical plants, Food processing units.



VISION

To Become the No. 1 company in the Industry which delivers quality products for its Customers, believes in Innovation to meet the changing needs of the Customers and Market and are able to keep their Employees and stakeholders Happy and Satisfied, thus ensuring their growth along with the Company.

MISSION

To Serve our Customers as their most trusted and reliable partner in the Blower Industry.

VALUES

- Passion to Win & Be-The-Best at whatever we do.
- Integrity knowing what is right and acting responsibly with our clients, colleagues and community.
- Innovation anticipating our clients' needs.
- Dedication for unparalleled quality and proven success.
- Guidance serving our client with experienced guidance regarding their actual needs.



WORKING PRINCIPLE

Ring Blowers, also known as Side Channel / Regenerative Blowers, are directly driven by electric motors. The impeller in the blowers are mounted directly on the motor shaft for contact free compression, without friction. Maximum operational reliability and service life, even at high differential pressures, is ensured by the arrangement of the bearings outside the compression chamber.

Imparts velocity to the inlet air in the direction of rotation. Centrifugal force in the impeller blades accelerates the air outward and resulting in pressure increases

High pressure air is discharge from the outlet of the blower

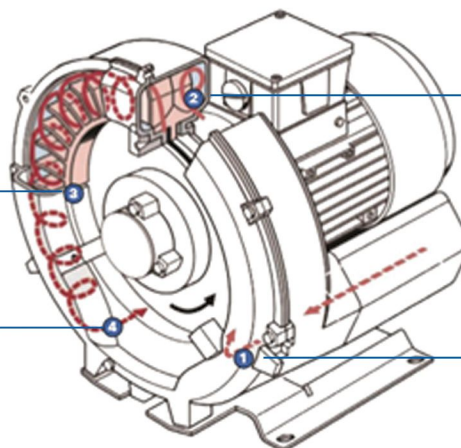

Rotating Impeller

Air inlet

RING BLOWER FEATURES:

- 100% oil free air
- Low noise level due to internal silencer
- Less vibration
- External bearing increase life
- Suitable for Pressure & Vacuum application
- Fully Copper Winding
- Pulsation free air
- Low power consumption
- Easy installation
- Direct drive motor design
- Low maintenance
- Compact in design (Space saving)

SINGLE STAGE RING BLOWER							
MODEL	POWER	DISPLACEMENT	VACUUM	PRESSURE	PRESSURE PSI	SOUND	WEIGHT
ARB-SS-25	0.25 HP	80 M3/hr/47 CFM	120 mbar	120 mbar	1.74 PSI	53 DB	9 KG
ARB-SS-80	0.5 HP	80 M3/hr/47 CFM	130 mbar	140 mbar	2.03 PSI	62 DB	12 KG
ARB-SS-145	1 HP	145 M3/hr/85 CFM	150 mbar	160 mbar	2.32 PSI	63 DB	14 KG
ARB-SS-210L	1.5 HP	210 M3/hr/123 CFM	170 mbar	170 mbar	2.46 PSI	64 DB	22 KG
ARB-SS-210	2 HP	210 M3/hr/123 CFM	190 mbar	200 mbar	2.9 PSI	70 DB	23 KG
ARB-SS-270	3 HP	270 M3/hr/123 CFM	230 mbar	250 mbar	3.91 PSI	67 DB	27 KG
ARB-SS-320V	4 HP	320 M3/hr/188 CFM	270 mbar	290 mbar	4.2 PSI	69 DB	37 KG
ARB-SS-400	5 HP	400 M3/hr/235 CFM	290 mbar	330 mbar	4.78 PSI	77 DB	40 KG
ARB-SS-530	7.5 HP	530 M3/hr/312 CFM	300 mbar	320 mbar	4.64 PSI	80 DB	62 KG
ARB-SS-530P	10 HP	530 M3/hr/312 CFM	320 mbar	380 mbar	5.51 PSI	82 DB	68 KG
ARB-SS-1050	11 HP	1050 M3/hr/618 CFM	210 mbar	210 mbar	3.04 PSI	77 DB	93 KG
ARB-SS-1050P	16.5 HP	1050 M3/hr/618 CFM	280 mbar	270 mbar	3.91 PSI	80 DB	116 KG
ARB-SS-1050HP	24.5 HP	1050 M3/hr/618 CFM	340 mbar	460 mbar	6.67 PSI	82 DB	126 KG

DOUBLE STAGE RING BLOWER							
MODEL	POWER	DISPLACEMENT	VACUUM	PRESSURE	PRESSURE PSI	SOUND	WEIGHT
ARB-DS-88	1 HP	88 M3/hr/52 CFM	210 mbar	240 mbar	3.48 PSI	55 DB	14 KG
ARB-DS-150	2 HP	150 M3/hr/88 CFM	280 mbar	280 mbar	4.06 PSI	66 DB	24 KG
ARB-DS-150V	3 HP	150 M3/hr/89 CFM	330 mbar	440 mbar	6.38 PSI	66 DB	27 KG
ARB-DS-230V	3 HP	230 M3/hr/135 CFM	290 mbar	360 mbar	5.22 PSI	72 DB	35 KG
ARB-DS-230	4 HP	230 M3/hr/135 CFM	340 mbar	410 mbar	5.94 PSI	72 DB	39 KG
ARB-DS-230P	5 HP	230 M3/hr/135 CFM	390 mbar	490 mbar	7.1 PSI	72 DB	45 KG
ARB-DS-320V	7.5 HP	320 M3/hr/188 CFM	440 mbar	500 mbar	7.25 PSI	73 DB	70 KG
ARB-DS-320P	10 HP	320 M3/hr/188 CFM	440 mbar	570 mbar	8.26 PSI	73 DB	77 KG
ARB-DS-520	15 HP	520 M3/hr/317 CFM	430 mbar	660 mbar	9.57 PSI	74 DB	123 KG
ARB-DS-1110P	27 HP	1110 M3/hr/653 CFM	440 mbar	500 mbar	7.25 PSI	74 DB	204 KG
ARB-DS-1110HP	33 HP	1110 M3/hr/653 CFM	440 mbar	590 mbar	8.55 PSI	74 DB	211 KG
ARB-DS-2050	27 HP	2050 M3/hr/1206 CFM	250 mbar	230 mbar	3.33 PSI	75 DB	230 KG
ARB-DS-2050P	33 HP	2050 M3/hr/1206 CFM	310 mbar	280 mbar	4.06 PSI	75 DB	235 KG



State of the Art Blower Engineering and Manufacturing

Applications

- Sewage Treatment Plants
- Electroplating Plants
- Water Treatment Plants
- Aeration
- Air Knife System
- Vacuum Conveying
- Vacuum De-Solders
- Vacuum Lifting & Feeding
- And Many More.



CONTACT US

AKASH BLOWERS PVT. LTD.

Call us at +91 702 702 9009

For Technical Support: customercare@akashblowers.com

 1710, 1712, 1713, M.I.E., Part-B, Bahadurgarh, Distt. Jhajjar, Haryana - 124507

 info@akashblowers.com  www.akashblowers.com

