

Pressure relief valve , pilot operated , Type DB;DBW

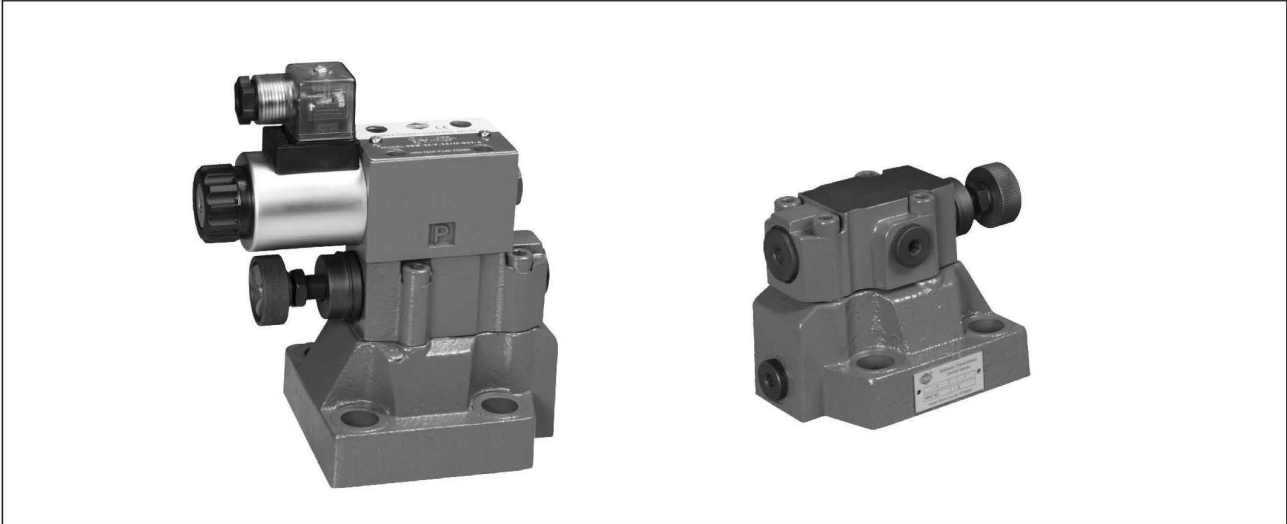

Introduction and Characteristic

- They are used for the limitation (DB) or limitation and solenoid actuated unloading (DBW) of the control pressure .
- Main valve's unloading can be done by installing solenoid operated directional valve.
- It also can be reduced impact when unloading by installing delay valve.

Ordering details

1	2	3	4	5	6	7	8	9	10
DB						- 5X /			

NO.	Version	Code	Explanation
1	Sort	DB	Pilot operated relief valve
2	Direction valve	No Code	Without direction valve
		W	With built-on directional spool valve
3		No Code	Pilot operated valve (complete)
		C	Pilot operated valve without main spool assembly (do not enter nominal size)
		C	Pilot operated valve with main spool assembly (enter valve size 10, 20, or 30)
		T	Pilot operated valve without main spool assembly for subplate mounting (do not enter nominal size)
4	Nominal size	10	Nominal size 10
		20	Nominal size 25
		30	Nominal size 32
5	Work state ^①	A	Normally closed
		B	Normally open
6	Adjustment elements	1	Rotary knob
		2★	Sleeve with hexagon and protective cap
		3★	Lockable rotary knob with scale
		7★	Rotary knob with scale
7	Series	5X	
8	Settable pressure	50	Settable pressure up to 5MPa
		100	Settable pressure up to 10MPa
		200	Settable pressure up to 20MPa
		315	Settable pressure up to 31.5MPa
		350	Settable pressure up to 35MPa
9	Pilot oil supply and drain line ^①	No Code	Pilot oil supply internal , pilot oil drain internal
		X	Pilot oil supply external , pilot oil drain internal
		Y	Pilot oil supply internal , pilot oil drain external
		XY	Pilot oil supply external , pilot oil drain external

Note :

- ① Only fit for pilot operated relief valve with solenoid controlled ;
- ② Waterproof degree of plug-in connector is above IP65;
- ★ Please consult us when you choose this application.

Ordering details

11	12	13	14	15	16	17	18	19	20
								S	

NO.	Version	Code	Explanation
10	Cracking pressure	No Code	Standard version
		U	Valve for minimum cracking pressure
11	Switching shock damping [★]	No Code	Switching , without switching shock damping
		S	With switching shock damping
12 ^①	Input voltage	W220	220V/50Hz、240V/60Hz
		W110	110V/50Hz、120V/60Hz
		RAC220	220V/50Hz、240V/60Hz
		RAC110	110V/50Hz、120V/60Hz
		G12	12V
		G24	24V
		G48	48V
13 ^①	Hand override	N9	With protected hand override (standard)
		N [★]	With hand override
14 ^①	Electrical connections	K4	Individual connection with component plug ISO4400 without plug-in connector
		DL	Terminal box with cable connector,with indicator light
15 ^①	Plug-in connector	No Code	Without plug-in connector
		Z4	With guadrate plug-in connector
		Z5L	Guadrate plug-in connector with indicator light
		F6L	With waterproof plug-in connector ^②
16 ^①	Throttle position	No Code	Without cartridge throttle
		P	Active in the P line
		A	Active in the A line
17 ^①	Throttle diameter	No Code	Without cartridge throttle
		08	Throttle Φ 0.8 mm
		10	Throttle Φ 1.0 mm
		12	Throttle Φ 1.2 mm
18	Seal material	No Code	NBR seals
		V	FKM seals
19		S	SUNNY fluid power technic
20			Futher details in clear text

Symbols

Type	...-...	...X...	...Y...	...XY...
DB				
DBW	Normally open			
	Normally closed			

Function

Functional description (Type: DB 10 1 5X/100)

Pass way P's pressure is on main spool 2. At the same time, pressure oil via throttle hole 11 to control pass way 10 and 8 on main spool 2's spring and pilot valve 9's ball 7. If pass way P's pressure is bigger than pilot valve spring's pressure, control oil reflows to oil box. (For internal drain type, control oil via pilot valve's spring cavity to main valve T port to oil box from pass way 4. For external drain type, pass way 4 installs screw plug 3. Control oil via pilot valve's drain port 6 to reflow oil box.) Then there is pressure difference between main spool up and down two sides. The pressure becomes up hydraulic power to drive spool 2 to move up. P port pressure oil start to relief to return oil port T and reflow oil box then. But P port pressure keeps fix.

Type: DBW...

Control oil road's switch can be come true by installing 2-position solenoid operated directional valve on DB series valve's pilot valve for DBW series valve.

Switching shock damping (Type: DBW...5X/...S...P10...S)

Control oil from P2 to P1's continuous delay is unlocked by installing shifting time delay valve 13 between pressure pilot valve 9 and solenoid operated directional valve 12 (See section and theory photo 14). So return oil road's pressure max. no. and unloading cushion can be reduced.

For unloading impact's cushion degree, it can be adjusted by installing different dimension's throttle is at solenoid operated directional valve's P port.

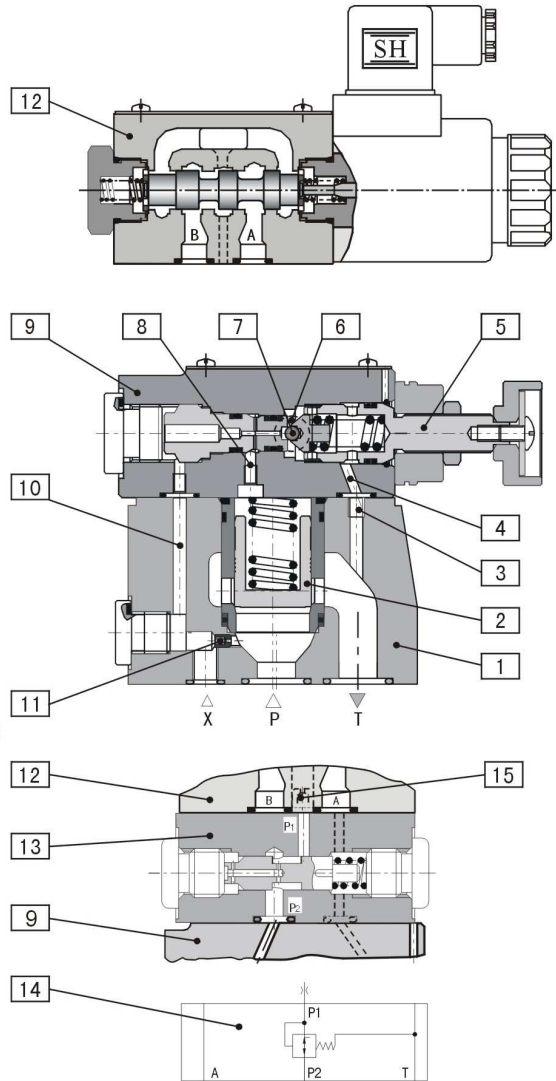

Technical data

General			Nominal size 10	Nominal size 25	Nominal size 32
Weight	DB...	Kg	2.60	3.50	4.40
	DBW...	Kg	4.05	4.95	5.85
	DBC...	Kg	1.20		
	DBWC...	Kg	2.65		
	DBC10/20/30...	Kg	1.50		
	DBWC10/20/30...	Kg	2.95		
Ambient temperature	DB...	NBR seals	°C	-30 to +80	
		FKM seals	°C	-15 to +50	
	DBW...	NBR seals	°C	-30 to +50	
		FKM seals	°C	-15 to +50	
Installation			optional		

Hydraulic			Nominal size 10	Nominal size 25	Nominal size 32
Max. Flow		L/min	250	500	650
Max. Operating pressure	Port P	MPa	35		
	Port T	MPa	31.5		
Max. Back pressure	Port Y DB...	MPa	31.5		
	Port Y (DBW.../...Y)	MPa	21 (=DC solenoids)		
	or Port T (DBW.../...)	MPa	16 (~AC solenoids)		
Settable pressure	Min.	MPa	Flow dependent (see characteristic curves)		
	Max.	MPa	5, 10, 20, 31.5, 35		
Pressure fluid:			Mineral oil (HL,HLP) to DIN 51524 ^① Fast bio-degradable pressure fluids to VDMA 24568; HETG(rape seed oil) ^① HEPG(Polyglycol);HEES(Synthetic ester) ^② ; Other fluids on request		
Pressure fluid temperature range	NBR seals	°C	-30 to +80		
	FKM Seals	°C	-20 to +80		
Viscosity range		mm ² /s	10 to 800		
Degree of contamination			Maximum permissible degree of contamination of fluid is to NAS 1638 class 9. We, therefore, recommend a filter with a minimum retention rate of $\beta_{10} \geq 75$.		

Electrical	See 4WE6/10 type valves on page 181
-------------------	-------------------------------------

● Inlet pressure in relation to the flow

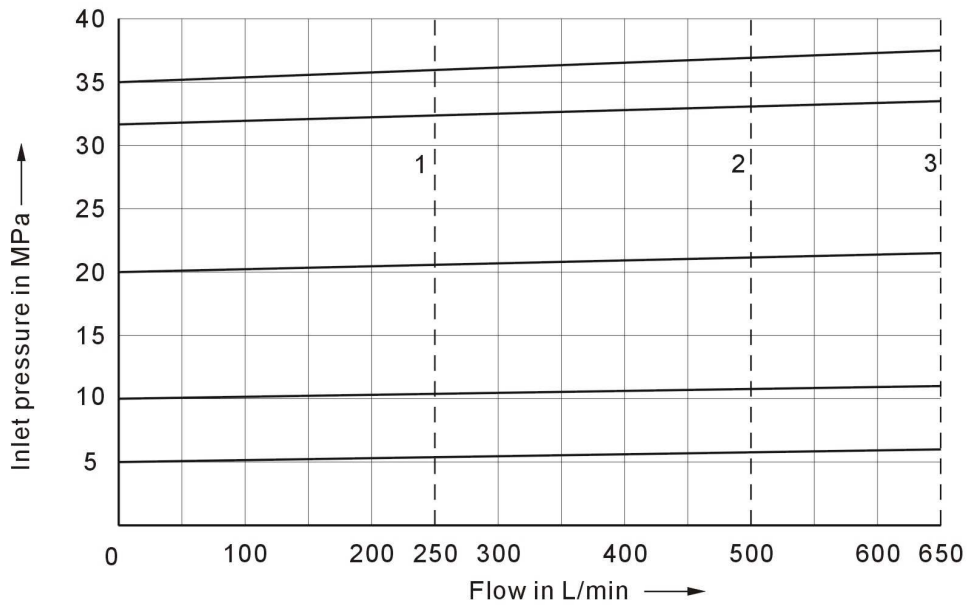

- 1 Size10
- 2 Size25
- 3 Size32

● Minimum settable pressure and bypass pressure in relation to the flow

Standard version (Type: DB...5X/...S)

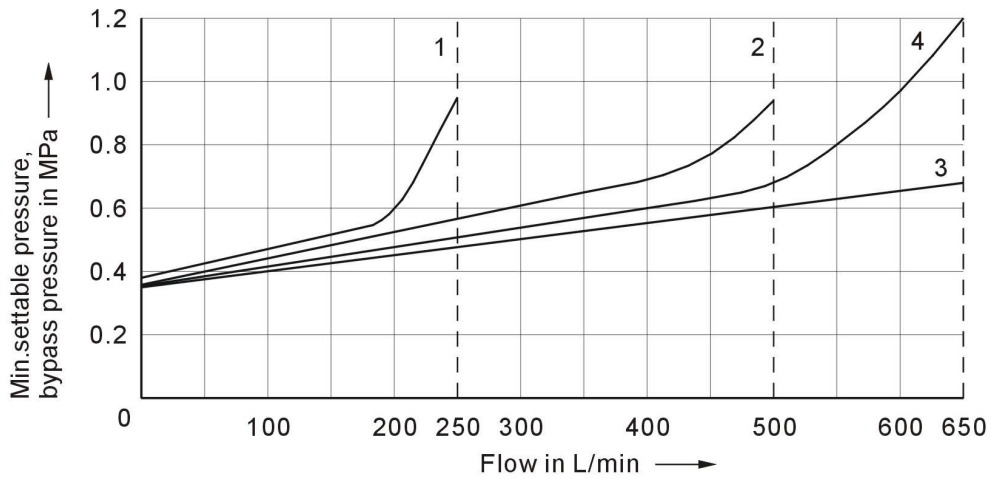

- 1 Size10
- 2 Size25
- 3 Size32
- 4 DBC30
DBWC30

Minimum cracking pressure (Type: DB...5X/...U...S)

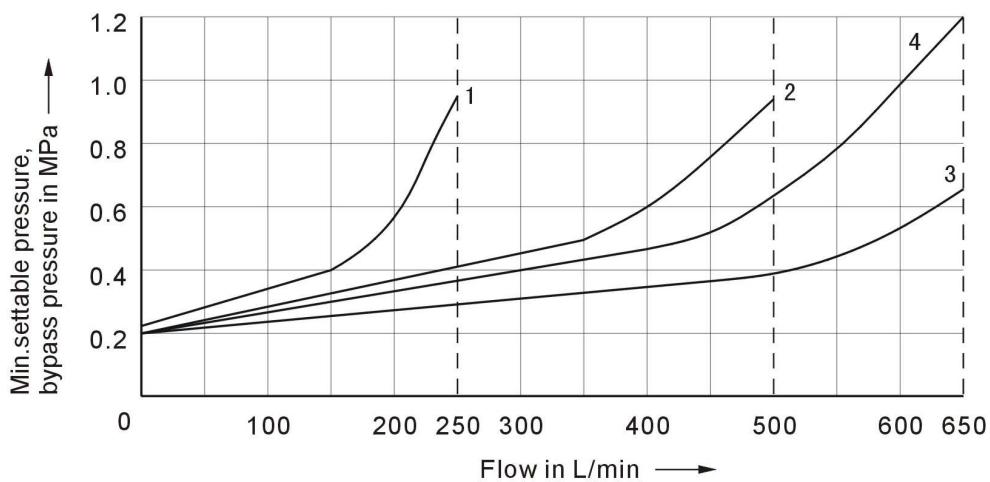

- 1 Size10
- 2 Size25
- 3 Size32
- 4 DBC30
DBWC30

Installation Dimensions : for subplate mounting

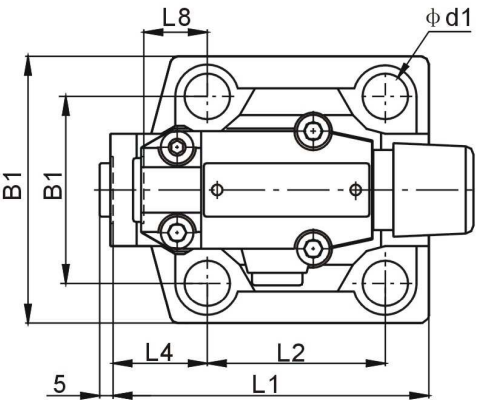
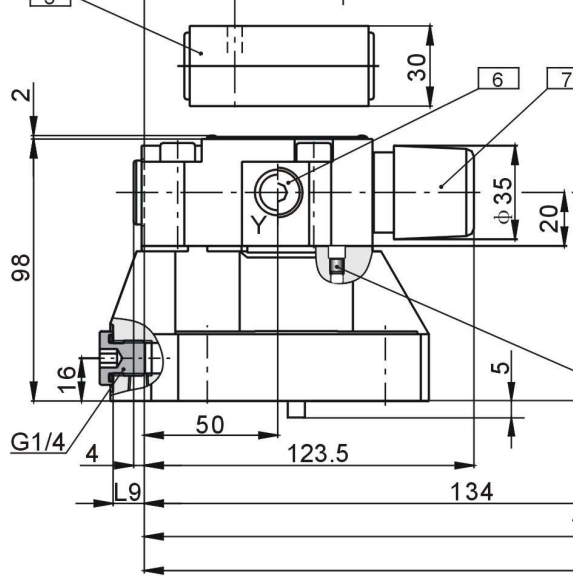
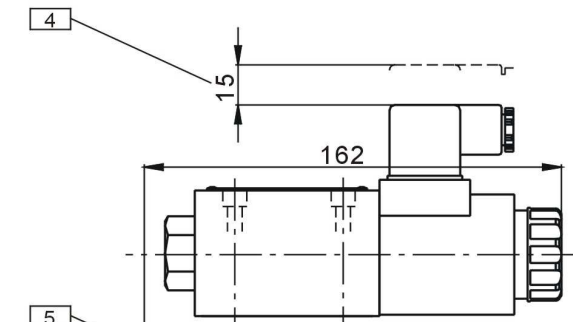
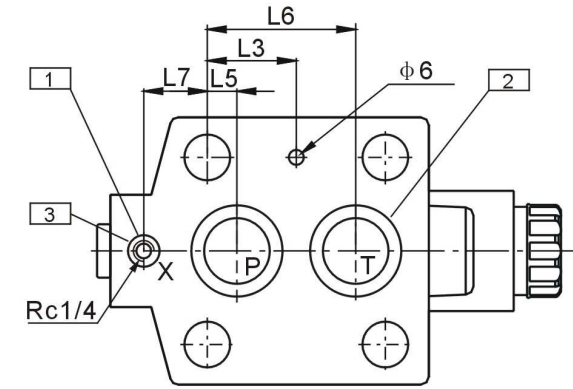

Item Explanation

- 1、 O Ring 8.8x1.9 (DB.10、 DB.20、 DB.30) ;
- 2、 DB.10: O Ring 2-17x2.5 ;
DB.20: O Ring 2-27.7x3.5 ;
DB.30: O Ring 2-33.7x3.5 ;
- 3、 X Port for external pilot ;
- 4、 Space for pulling out plug ;
- 5、 with shifting shock damping , optional ;
- 6、 Y Port (G1/4) for external pilot reflow ;
- 7、 Adjustment component with cap.bolts (S=10) ;
- 8、 Handwheel adjustment component ;
- 9、 Adjustment component with scale ;
- 10、 Adjustment component with scale and lock ;
- 11、 No installation when internal pilot reflow ;
- 12、 space for pulling out key ;

Valve fix bolts

- DB/DBW10: 4-M12x40, $M_A=130N \cdot M$
 DB/DBW20: 4-M16x45, $M_A=310N \cdot M$
 DB/DBW30: 4-M20x50, $M_A=430N \cdot M$
 Note: Bolt NO.: GB/T70.1-2000, Degree: 12.9

Type	L1	L2	L3	L4	L5	L6	L7
DB.10	91	53.8	22.1	27.5	22.1	47.5	0
DB.20	116	66.7	33.4	33.3	11.1	55.6	23.8
DB.30	147.5	88.9	44.5	41	12.7	76.2	31.8

Type	L8	L9	B1	B2	d1
DB.10	25.5	2	78	53.8	14
DB.20	22.8	10.5	100	70	18
DB.30	20	21	115	82.6	20

Installation Dimensions

DBC10/20/30...、DBC...And DBT...

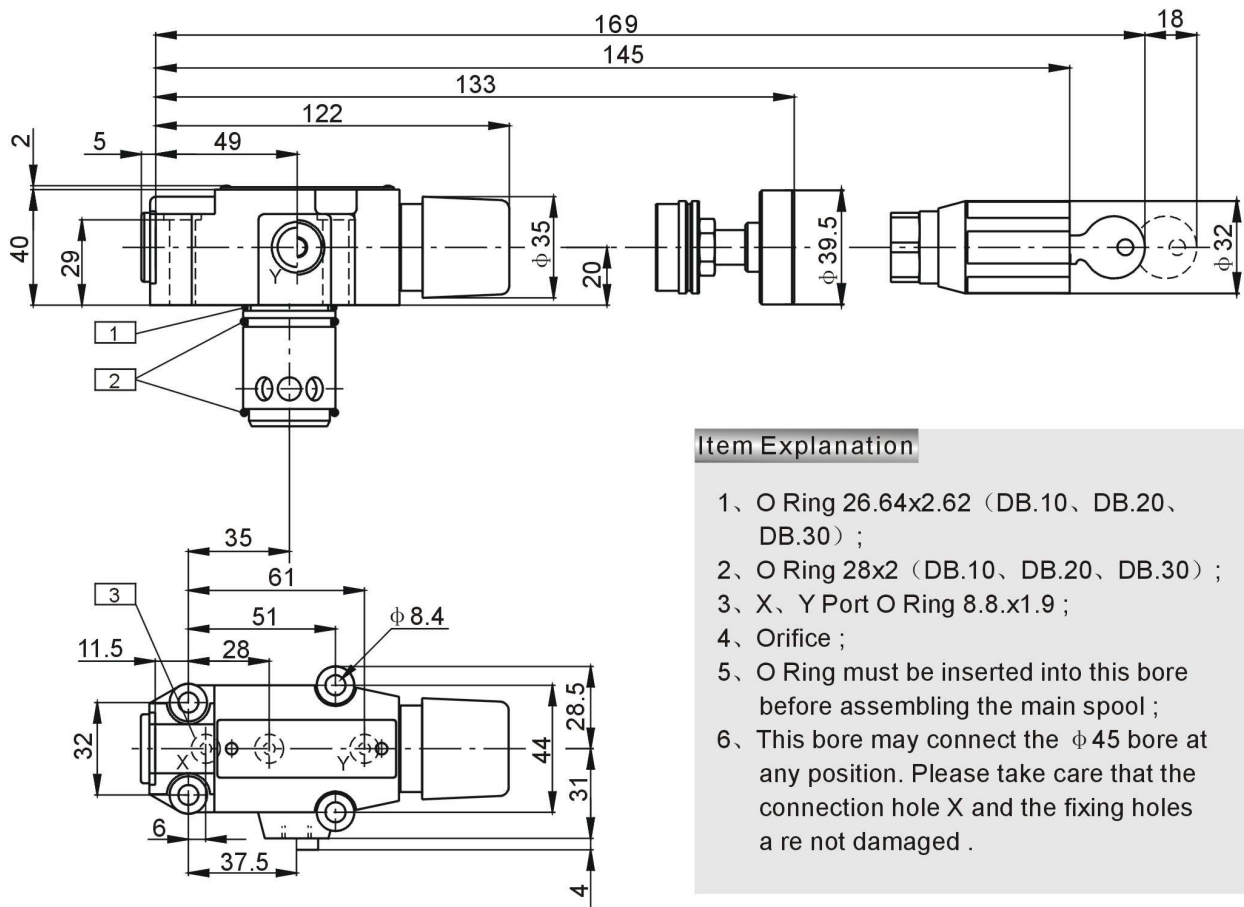

Item Explanation

- 1、O Ring 26.64x2.62 (DB.10、DB.20、DB.30) ;
- 2、O Ring 28x2 (DB.10、DB.20、DB.30) ;
- 3、X、Y Port O Ring 8.8x1.9 ;
- 4、Orifice ;
- 5、O Ring must be inserted into this bore before assembling the main spool ;
- 6、This bore may connect the $\phi 45$ bore at any position. Please take care that the connection hole X and the fixing holes are not damaged .

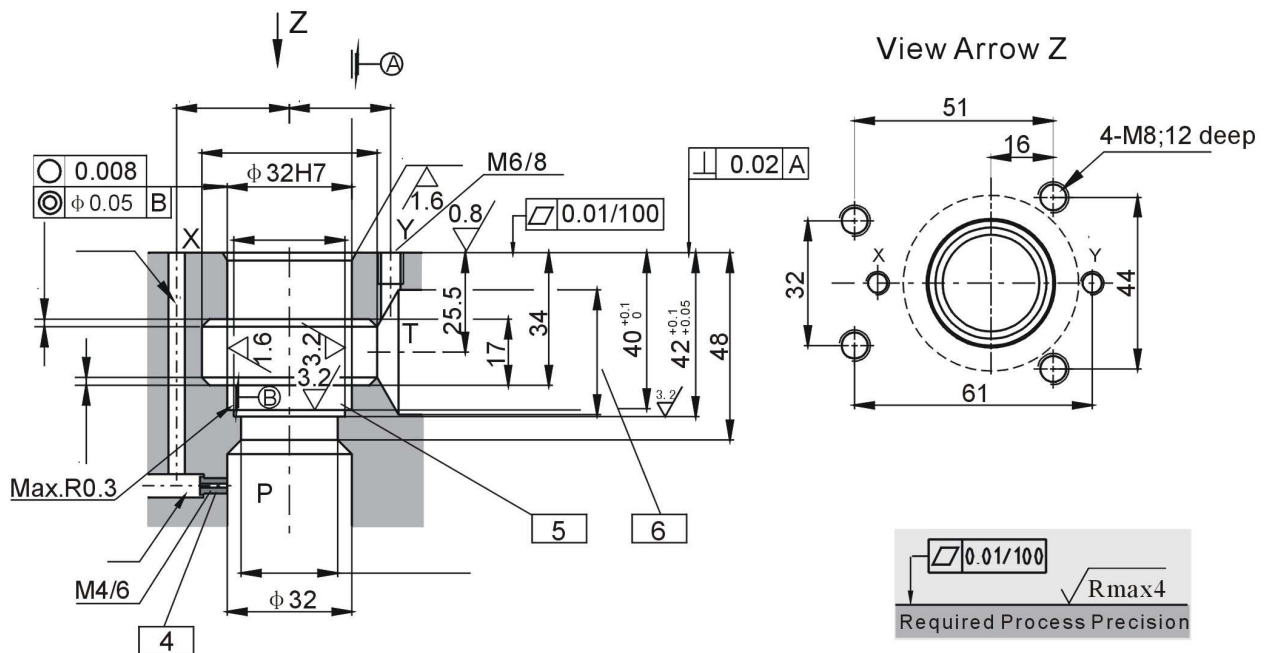

Subplate Installation Dimensions

DB/DBW10

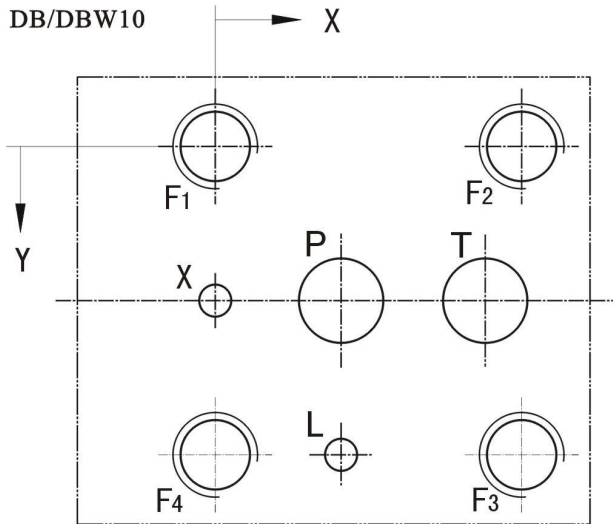

Type	Des. Code	Position		Character	
		X	Y		Deep
DB/DBW10	F ₁	0	0	M12	26
	F ₂	53.8	0	M12	26
	F ₃	53.8	53.8	M12	26
	F ₄	0	53.8	M12	26
	X	0	26.9	φ 4.8	–
	P	22.1	26.9	φ 14.7	–
	T	47.5	26.9	φ 14.7	–
	L	22.1	53.8	φ 4.8	7

DB/DBW20

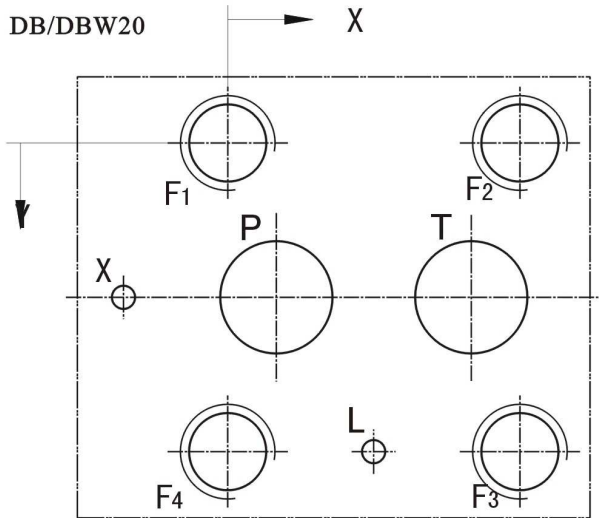

Type	Des. Code	Position		Character	
		X	Y		Deep
DB/DBW20	F ₁	0	0	M16	26
	F ₂	66.7	0	M16	26
	F ₃	66.7	70	M16	26
	F ₄	0	70	M16	26
	X	-23.8	35	φ 6.3	–
	P	11.1	35	φ 25	–
	T	55.6	35	φ 25	–
	L	33.4	70	φ 6.3	7

DB/DBW30

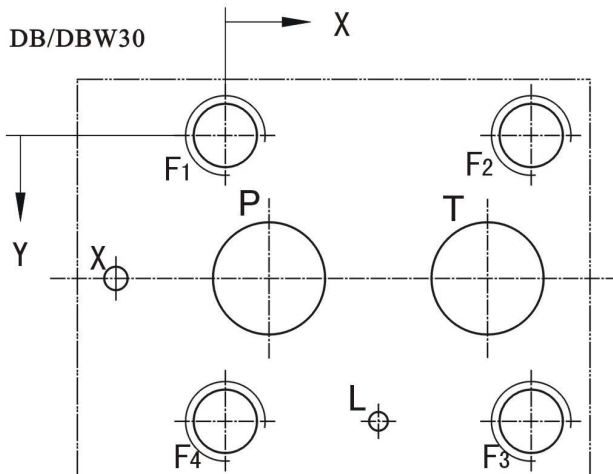

Type	Des. Code	Position		Character	
		X	Y		Deep
DB/DBW30	F ₁	0	0	M18	26
	F ₂	88.9	0	M18	26
	F ₃	88.9	82.6	M18	26
	F ₄	0	82.6	M18	26
	X	-31.8	41.3	φ 6.3	19
	P	12.7	41.3	φ 32	–
	T	76.2	41.3	φ 32	–
	L	44.5	82.6	φ 6.3	7

