

Rothe stands for creative innovation in machines and projects. We are driven by the search for excellence, the focus to achieve goals and challenges set by customers and the determination to strengthen the long-lasting relationships in confidentiality with customers.

We're manufacturer of Conveyors & Conveyor Systems, which are designed and manufactured on the basis of latest technology, Tested, Validated, Reliable and Efficient. This brings vertical start-up, which in turn reduces the time from investment to invoice & maximizes values for customer in the form of **|Profitability |Increase in productivity | Reduces maintenance& servicing cost.**



#### Rothe Packtech Pvt Ltd.

Gat No 191, Behind Jyotiba Mandir, Jyotiba Nagar,  
Talwade Pune- 411062

M: 9822267494 E: enq@rothe.in W: www.rothe.in

#### ➤ Products Range

- Standard Conveyors
- Turnkey Conveyor Solution
  - Sorting System
  - Lane Divertor
  - Merging System

#### ➤ Application

- Logistics & Warehouse Industry
- FMCG industry
- Food Industry
- Liquor and Brewery Industry
- Agriculture industry



Sorting System is the latest technology which is highly accurate and efficient in sorting, routing, consolidating, diverting a wide range of parcel types to unique destinations for the purpose of order selection, processing, packaging, palletizing, storing & shipping.



**BARCODE SCANNING SYSTEM**

Full line of barcode systems and hardware solutions designed to simplify warehouse problems.

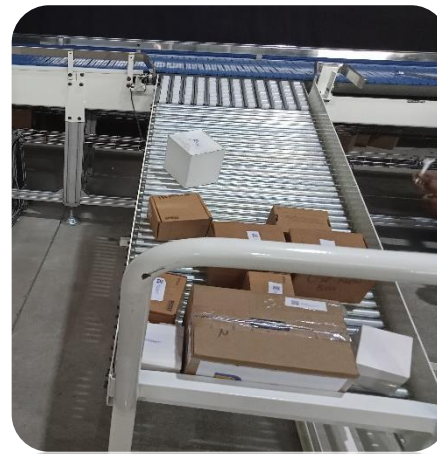

**CROSS TRANSFER CONVEYOR**

Transfer and Cross Conveyors are employed to accumulate, feed, and discharge material to respective places.



**COMPLETE SORTING SYSTEM**

to identifying and classifying the different products, and transport them to the respective points.





**FLAT BELT CONVEYOR**

- High weight carrying capacity
- High speed & Smooth running
- Long path moment possible, Easy to handling

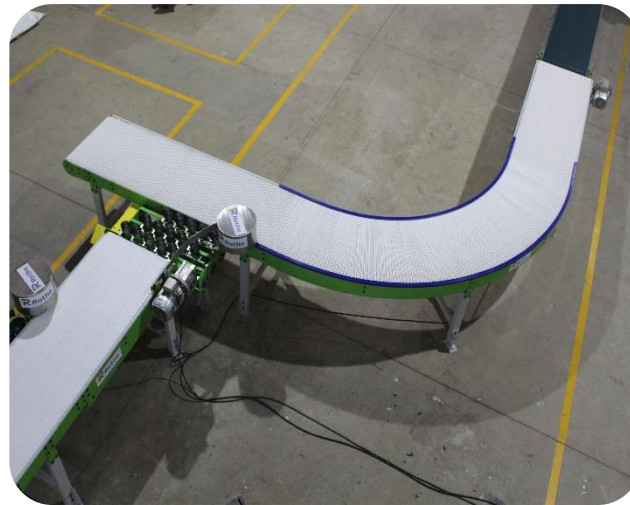

**MODULAR CONVEYOR**

- High weight carrying capacity
- High speed & Smooth running
- Long path moment possible, Easy to handling



**ROLLER CONVEYOR**

- High weight carrying capacity
- High speed & Smooth running
- Long path moment possible, Easy to handling



Product





## KNIFE EDGE CONVEYOR

Uniquely designed end Section.  
 Safely transfer the Small Product to move one conveyor to another.  
 Prevent fall between the gap.  
 Reduce friction between to two belt conveyors.

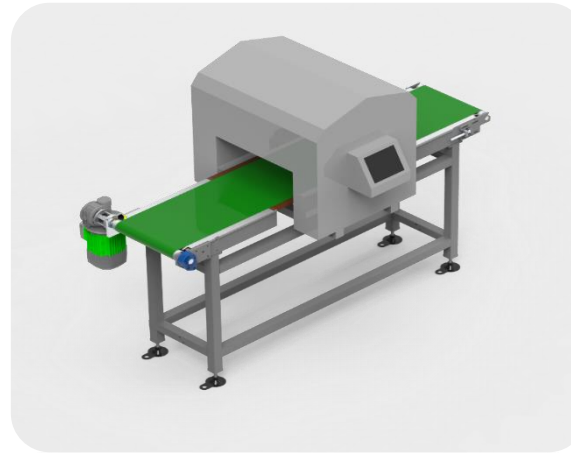

## METAL DETECTOR CONVEYOR

Fully automated detect-and-reject systems.  
 Metal detection system food & non-Food items.  
 Quality inspection & mark safety concern.

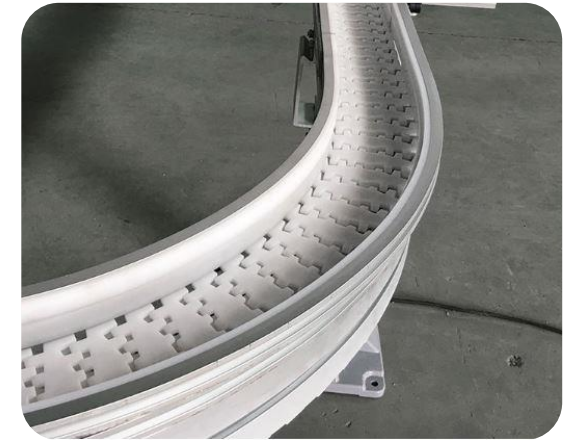

## FLEX-LINK CONVEYOR

High Speed  
 Robust Design, Smooth 90° Transfer  
 Used for small Products  
 No Product tipping, Heat Resistant

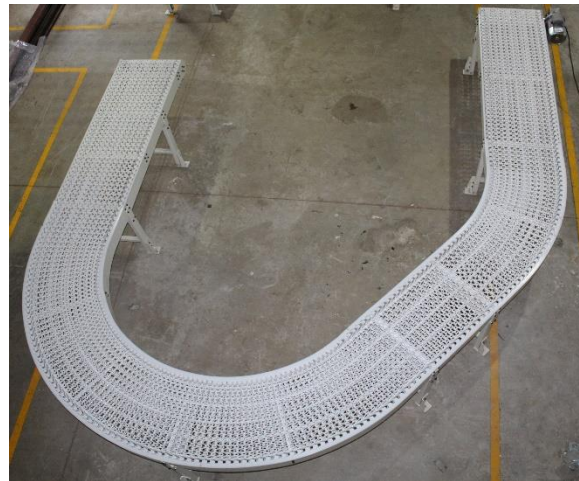
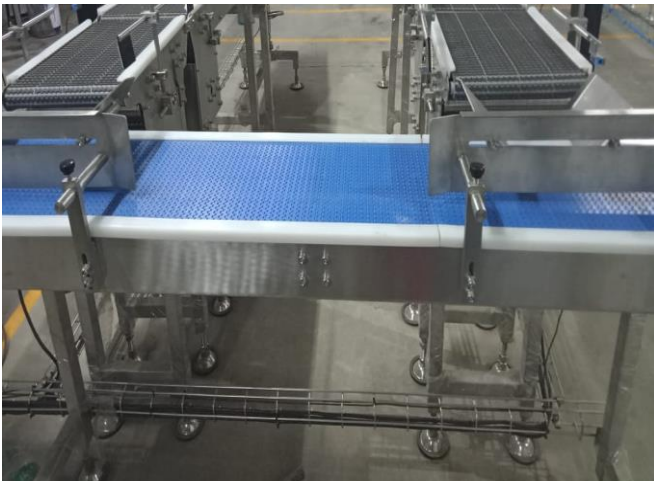

Product



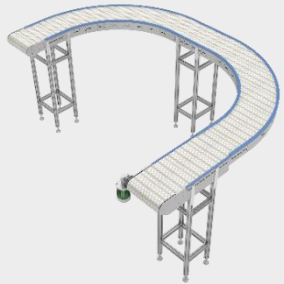

Bend Conveyor



Pallet Conveyor

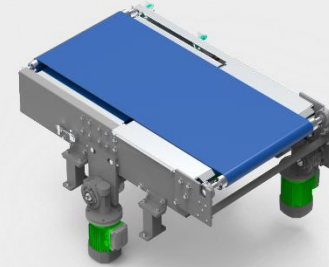

Telescopic Conveyor



ARB Conveyor



Turn Table Conveyor



Vertical Lifter

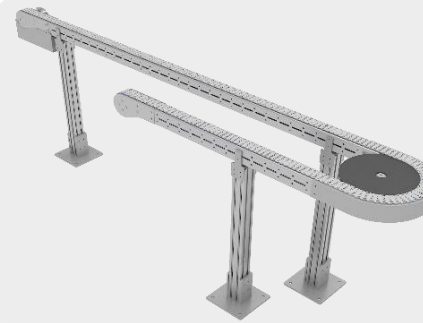

Slat Chain Conveyor



Weighing Conveyor



Printer Conveyor



Roller Turn / POP



Take Off Conveyor



Nose Bar Conveyor

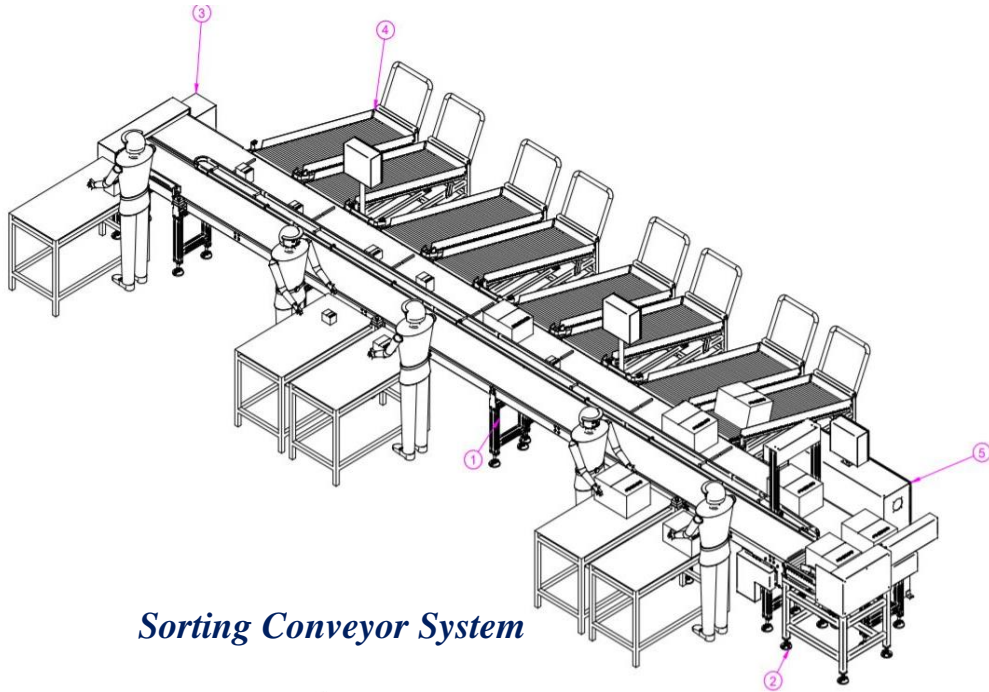

*Sorting Conveyor System*

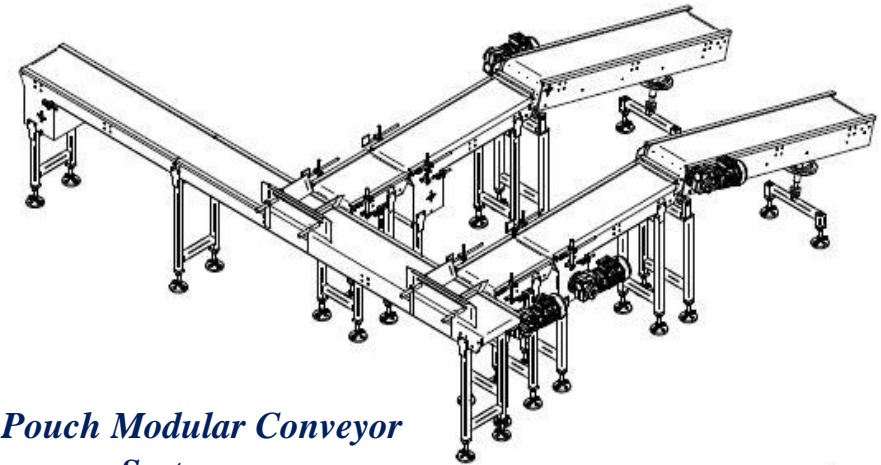

*Oil Pouch Modular Conveyor System*

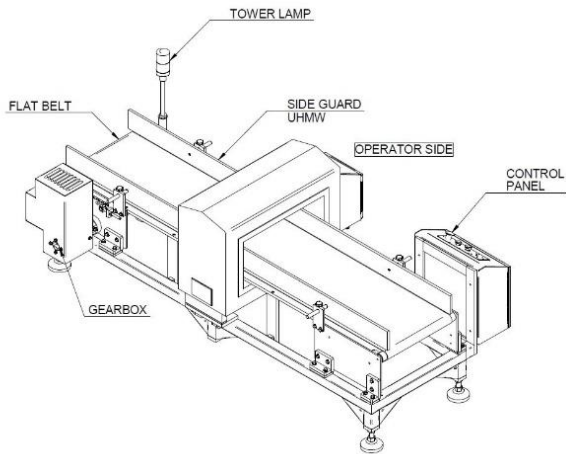

*Metal Detector Conveyor*

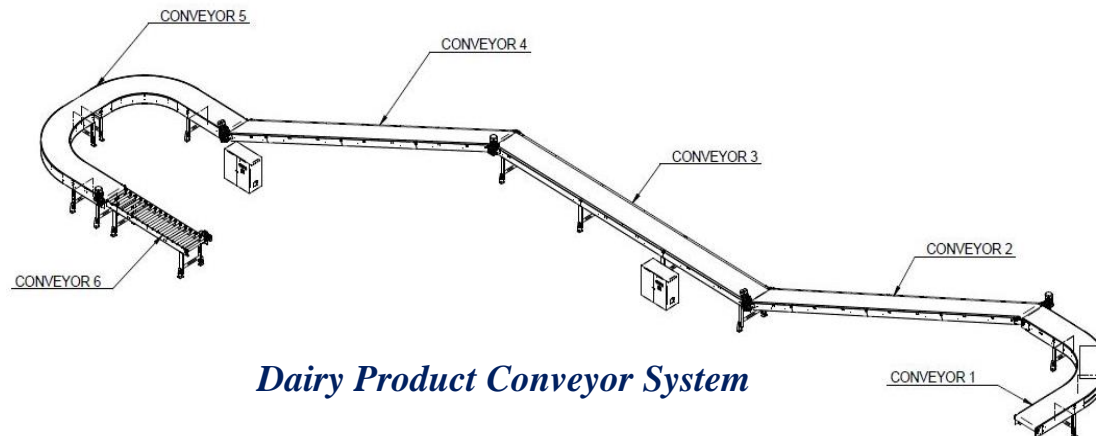

*Dairy Product Conveyor System*

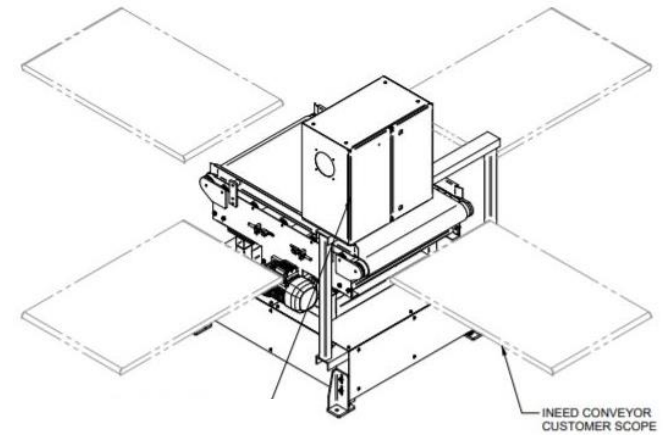

*360° Turn Conveyor System*



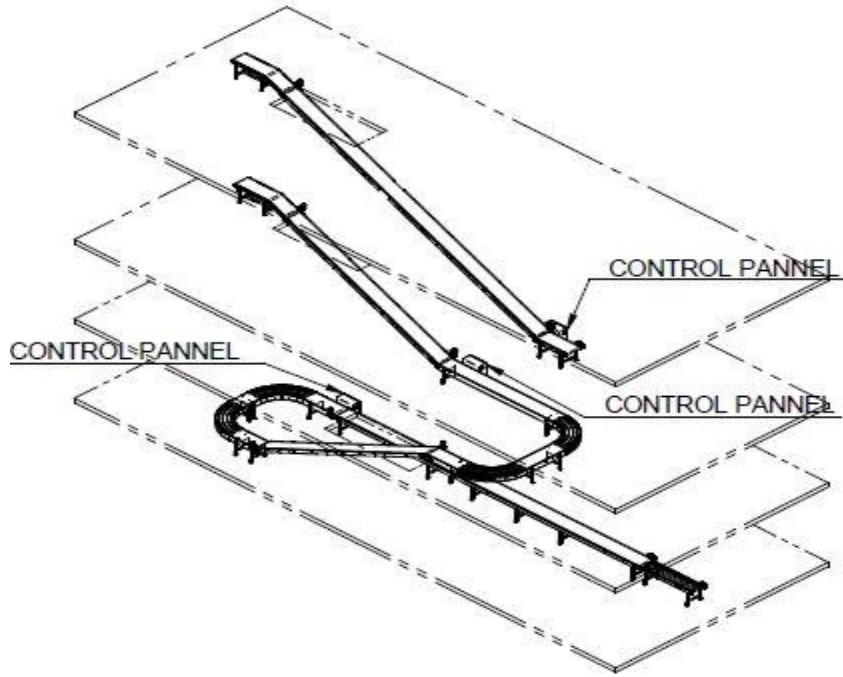

*3- Floor Conveyor System*

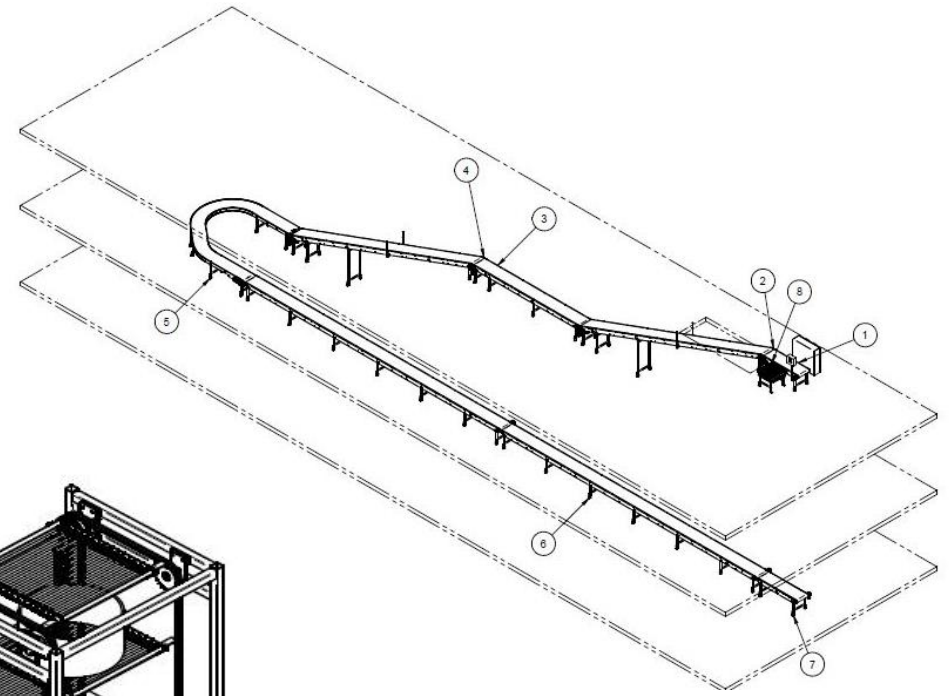

*2- Floor Conveyor System*

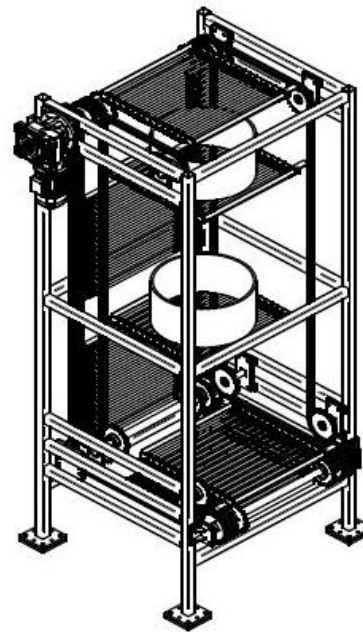

*Vertical Lifter System*

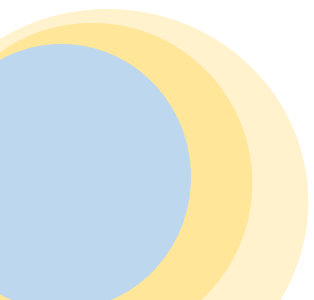





ROTHE PACKTECH PVT LTD.

Gat No 191, Behind Jyotiba Mandir, Jyotiba Nagar, Talwade Pune- 411062

M: 9822267494 E: enq@rothe.in W: www.rothe.in

