

Company Profile

ABOUT US

Director

Mr. Ravindra Rothe

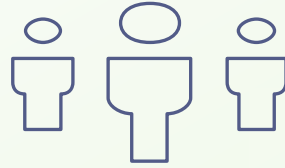

We're manufacturer of Industrial Automation ,which are designed and manufactured on the basis of latest technology, Tested ,Validated ,Reliable and Efficient. This brings vertical start-up, which in turn reduces the time from investment to invoice & maximizes values for customer in the form of Profitability, Increase in productivity, Reduces maintenance & servicing cost .

We have successfully designed, manufactured, installed and commissioned 40+ projects which includes 100+ machines. A conveyor line up to 400 meter in a single project has been successfully installed and commissioned.

Rothe stands for creative innovation, driven by the search for excellence, the focus to achieve goals and challenges set by customers. We take pride in putting customer first as they are what keeps our company going. We endeavour to strengthen the long lasting relationships in confidentiality with customers

Vision And Mission

OUR VISION

“TO BECOME WORLDWIDE PREFERRED PARTNER OF CHOICE FOR PROVIDING SOLUTIONS THAT RELENTLESSLY SURPASSED CUSTOMER EXPECTATIONS”

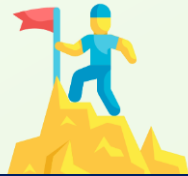

OUR MISSION

“TO BRING FORTH STATE-OF-ART SOLUTION COMMERCIAL, FOOD AND FMCG INDUSTRIES THAT ARE THOROUGHLY TESTED, VALIDATED, RELIABLE AND EFFICIENT”

OUR CORE VALUES

PEOPLE

FLEXIBILITY

RELIABILITY

CUSTOMER FIRST

CONTINUOUS IMPROVEMENT AND INNOVATION



OUR USP

Flexibility

Wide experience

Robust programming

Customer relationships

Responsible organization

Strong Application engineering

Vertical Start-up Automation System

Mechanical design- strong conceptualization

Strength - Design, PC&IS, manufacturing, Application engineering, Validation process

5 Stage validation process: Dry Run Test, Static Test, Induce Failure Test, BSPRT Test, Change over test



WE OFFER



WHAT WE OFFER

- LISTENING TO THE CUSTOMERS
- REQUIREMENT ANALYSIS
- LAYOUT DESIGN & EQUIPMENT SELECTION.
- LINE INTEGRATION, ELECTRICAL & MECHANICAL SYNCHRONIZATION
- INSTALLATION, COMMISSIONING AND TRAINING.
- AFTER SALES SUPPORT.
- SPARES SUPPLY.



OUR PRODUCTS

SPECIAL PURPOSE MACHINE (SPM)

PALLETIZER SYSTEMS

CASE ERECTORS

CASE PACKER SYSTEMS

OUTBOUND AUTOMATION

VERTICAL STARTUP AUTOMATION

ROBOTIC PICK AND PLACE

CONVEYOR SOLUTIONS

FG PALLET HANDLING SOLUTION

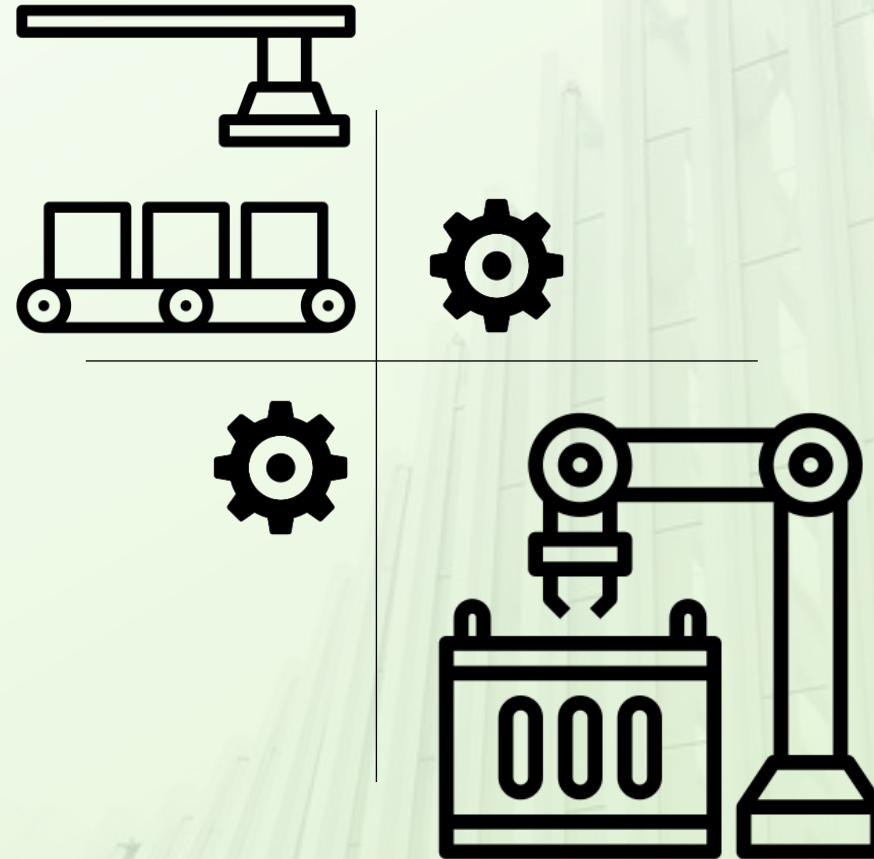

OUR PRODUCTS

SPECIAL PURPOSE MACHINE (SPM)

PALLETIZER SYSTEMS

CASE ERECTORS

CASE PACKER SYSTEMS

OUTBOUND AUTOMATION

VERTICAL STARTUP AUTOMATION

ROBOTIC PICK AND PLACE

CONVEYOR SOLUTIONS

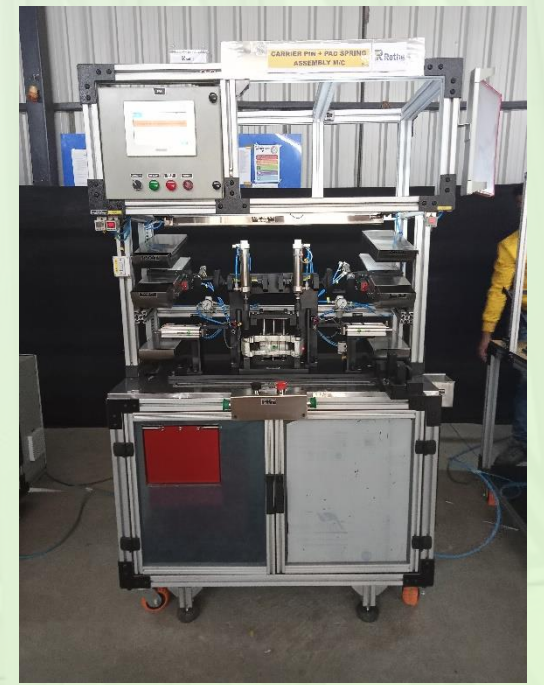

OUR PRODUCTS

SPECIAL PURPOSE MACHINE (SPM)

PALLETIZER SYSTEMS

CASE ERECTORS

CASE PACKER SYSTEMS

OUTBOUND AUTOMATION

VERTICAL STARTUP AUTOMATION

ROBOTIC PICK AND PLACE

CONVEYOR SOLUTIONS



Gantry Palletizer

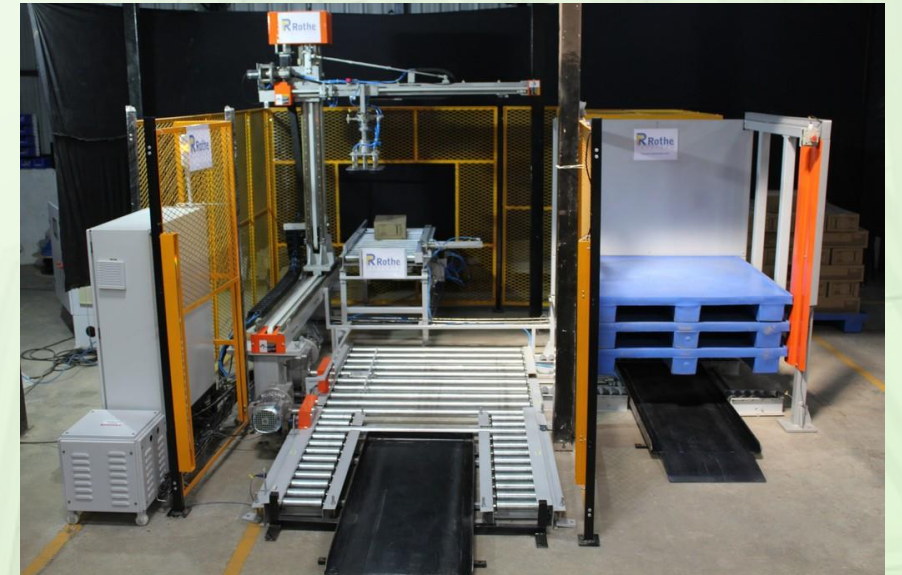
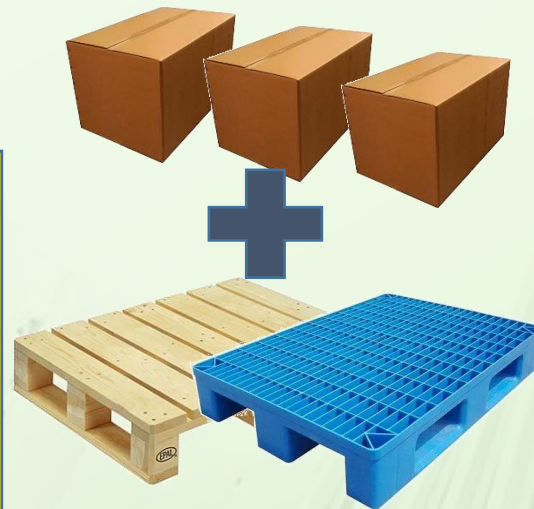

Low Speed Palletizer

OUR PRODUCTS

- SPECIAL PURPOSE MACHINE (SPM)
- PALLETIZER SYSTEMS
- CASE ERECTORS**
- CASE PACKER SYSTEMS
- OUTBOUND AUTOMATION
- VERTICAL STARTUP AUTOMATION
- ROBOTIC PICK AND PLACE
- CONVEYOR SOLUTIONS

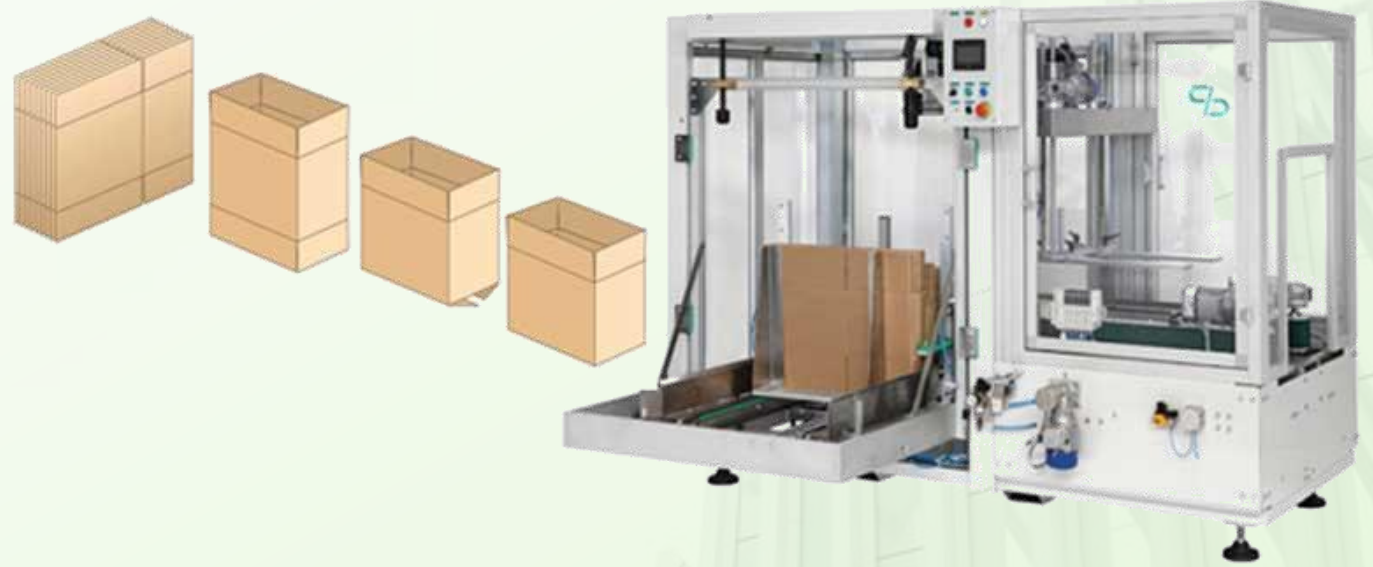

Case Erector & Bottom taping

OUR PRODUCTS

SPECIAL PURPOSE MACHINE (SPM)

PALLETIZER SYSTEMS

CASE ERECTORS

CASE PACKER SYSTEMS

OUTBOUND AUTOMATION

VERTICAL STARTUP AUTOMATION

ROBOTIC PICK AND PLACE

CONVEYOR SOLUTIONS



Pick & Place Case Packer

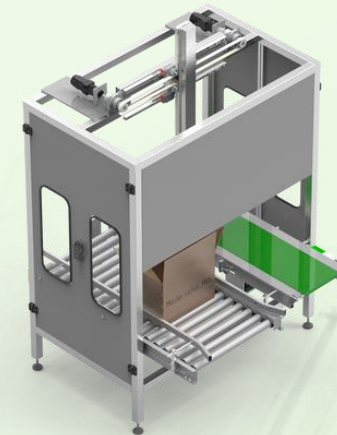

Drop Case Packer – French Fries

OUR PRODUCTS

SPECIAL PURPOSE MACHINE (SPM)

PALLETIZER SYSTEMS

CASE ERECTORS

CASE PACKER SYSTEMS

OUTBOUND AUTOMATION

VERTICAL STARTUP AUTOMATION

ROBOTIC PICK AND PLACE

CONVEYOR SOLUTIONS



Automatic Sorting System

OUR PRODUCTS

SPECIAL PURPOSE MACHINE (SPM)

PALLETIZER SYSTEMS

CASE ERECTORS

CASE PACKER SYSTEMS

OUTBOUND AUTOMATION

VERTICAL STARTUP AUTOMATION

ROBOTIC PICK AND PLACE

CONVEYOR SOLUTIONS



Automatic Bag Cutting Machine

OUR PRODUCTS

SPECIAL PURPOSE MACHINE (SPM)

PALLETIZER SYSTEMS

CASE ERECTORS

CASE PACKER SYSTEMS

OUTBOUND AUTOMATION

VERTICAL STARTUP AUTOMATION

ROBOTIC PICK AND PLACE

CONVEYOR SOLUTIONS



We are authorised
channel partner for
Mitsubishi Robots



OUR PRODUCTS

SPECIAL PURPOSE MACHINE (SPM)

PALLETIZER SYSTEMS

CASE ERECTORS

CASE PACKER SYSTEMS

OUTBOUND AUTOMATION

VERTICAL STARTUP AUTOMATION

ROBOTIC PICK AND PLACE

CONVEYOR SOLUTIONS

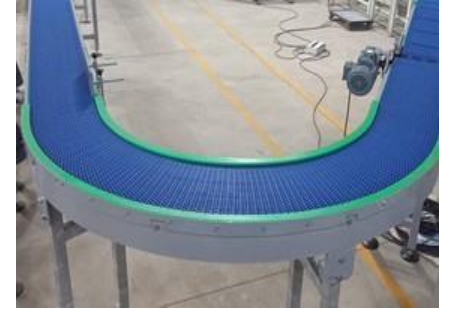

OUR PRODUCTS

PALLETIZER SYSTEMS

CASE ERECTORS

CASE PACKER SYSTEMS

OUTBOUND AUTOMATION

VERTICAL STARTUP AUTOMATION

ROBOTIC PICK AND PLACE

CONVEYOR SOLUTIONS

FG PALLET HANDLING SOLUTION

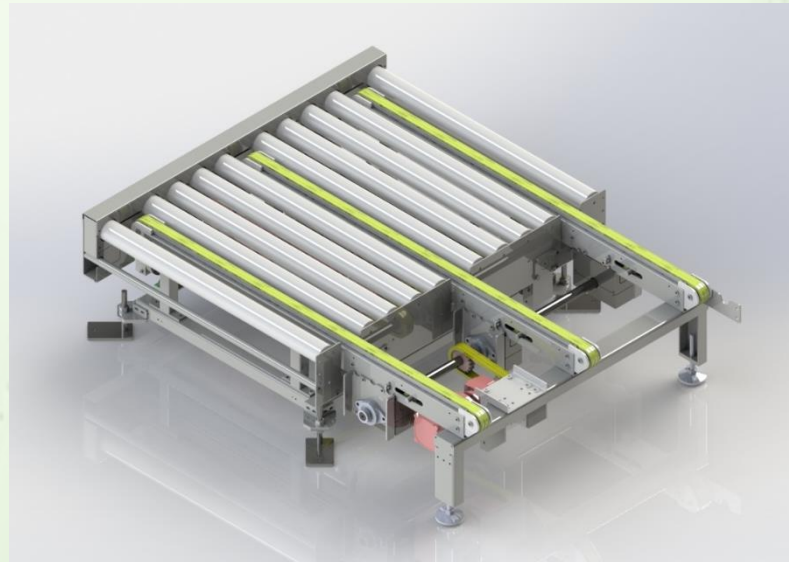
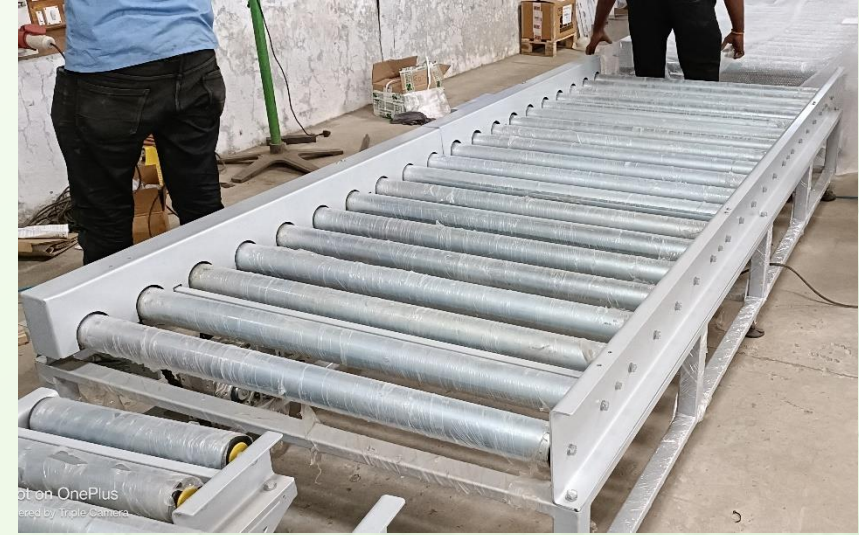

OUR LATEST EXCEUTED CONVEYORS SOLUTIONS LAYOUT

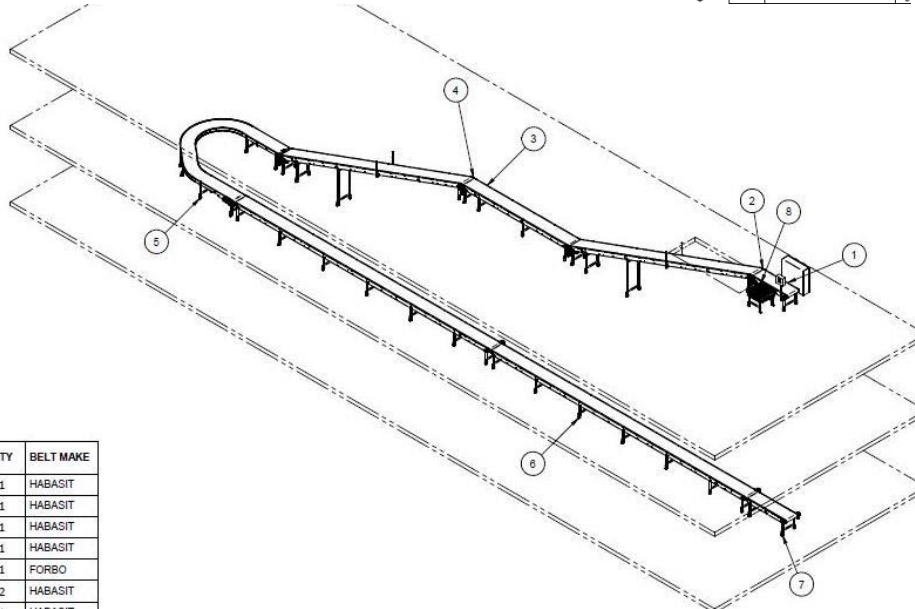
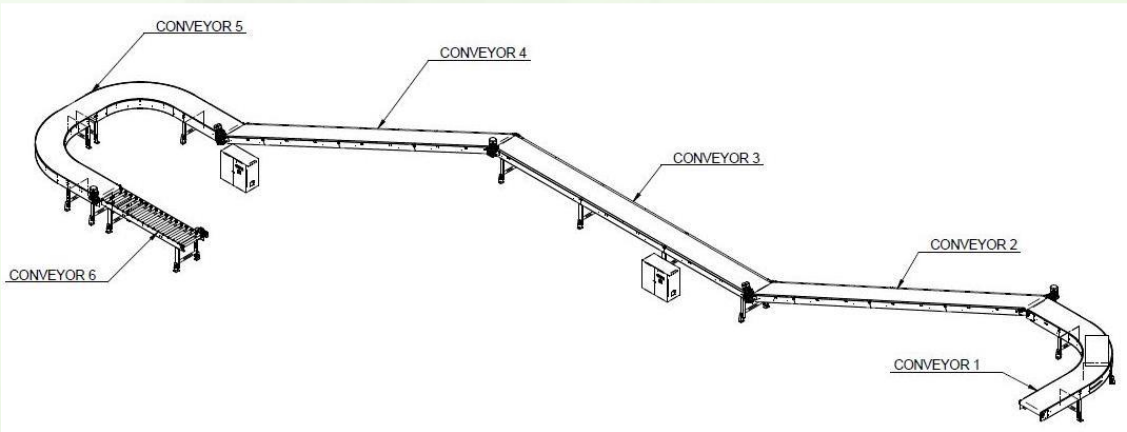
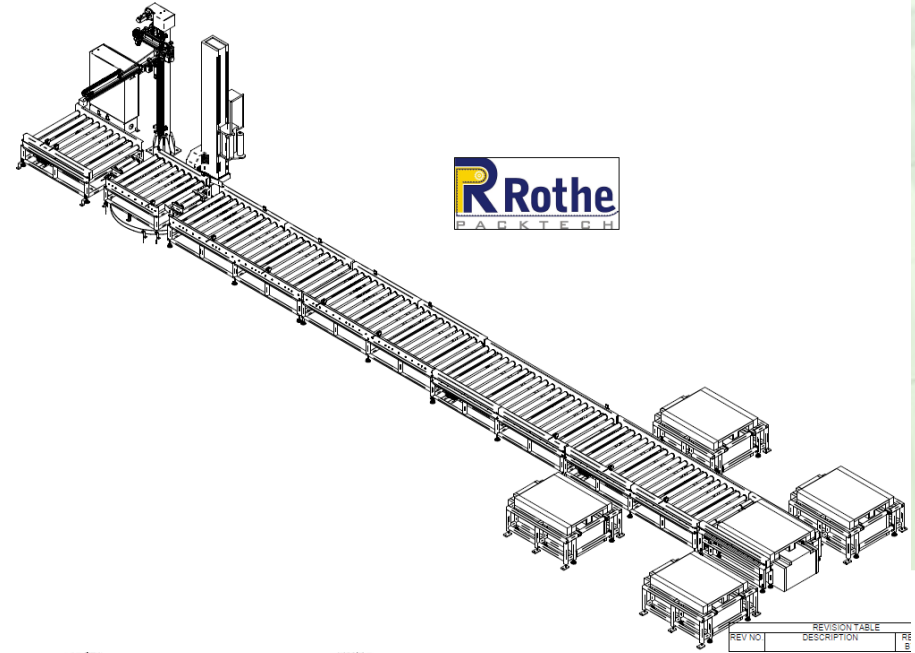
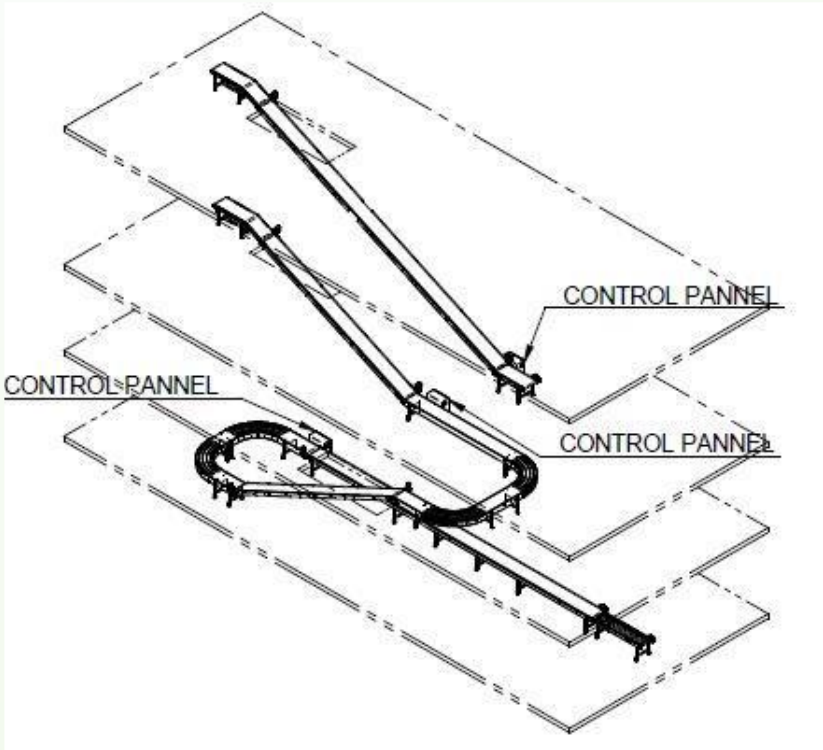

TY	BELT MAKE
1	HABASIT
1	HABASIT
1	HABASIT
1	HABASIT
1	FORBO
2	HABASIT

WE HAVE SERVED

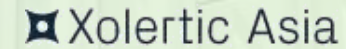

HOLM KK EXTRUSIONS
PROVIDING THE BEST SOLUTION IN TIME



THE TECHNOLOGIES WE USE

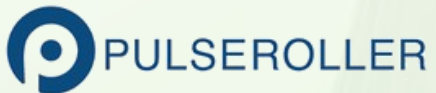



Address-

Gat No 191, Behind Jyotiba Mandir ,
Jyotiba Nagar ,Talwade Pune- 411062



Sales & Marketing Contact's-

Yogesh Pokle

M: +91 8956297401

E: yogesh@rothe.in



Ashwini Ade

M: +91 9096662970

E: sales01@rothe.in



Ravindra Rothe

M: +91 9822267494

E: enq@rothe.in

