



TRII-PLEX

JETTECH SYSTEMS

HIGH PRESSURE PLUNGER PUMPS

FLOWRATE: - Up to 130 LPM

PRESSURE:- 1300 BAR

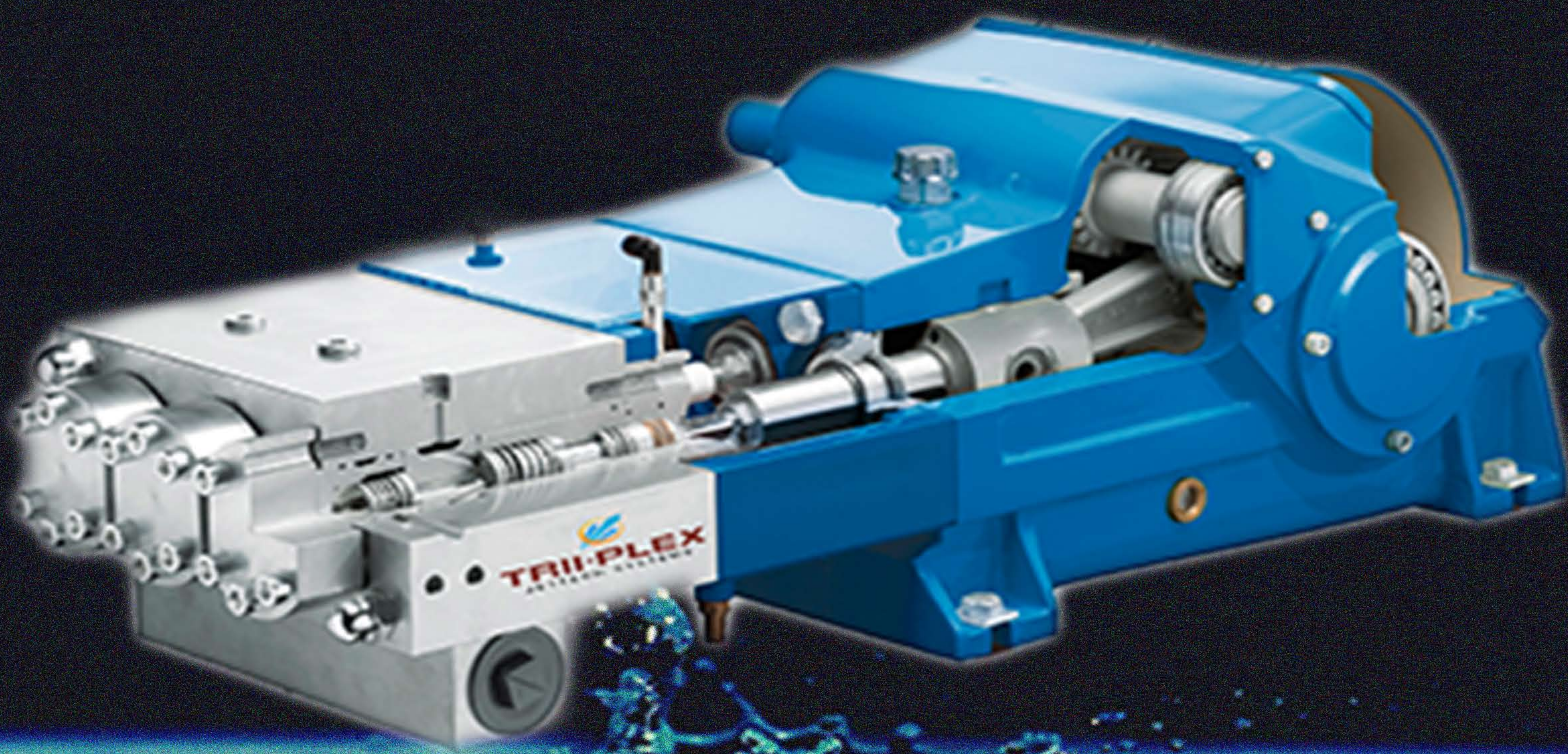

Applications:

Cleaning of Evaporators, Condensers, Heat Exchanger Tubes & Pipes, Pre-heaters, Reactors, Pressure Vessels, Tube Bundles, Turbine Blades, Ship Hull, Coach / Bogies, Air-filters, Silos, Tanks, Machined parts, Sewage Pipes, Coolers, Descaling of Billets, Blooms, Plates, Spring Sheets, Forgings, Pipes, Non Ferrous Metals, External Cleaning. Also Using for Hydro Test Application.

Industries:

Manufacture Industries, Sugar Plants, Thermal Power Plants, Steel Industries, Cement Industries, Chemical Industries, Cross Country Pipe Line, Airports, Engineering, Automobiles, Fertilizers, Construction, Foundries, Metallurgical Plants, Mining, Milk & Food Processing, Municipalities, Oil Refineries, Paper & Pulp, Textile Industries, Petrochemical Industries, Pipe Industries, Railway Industries, Defense, Aluminum, Ship Building, Wind Farm & many more.

Other accessories:

Suction Hose, High Pressure Delivery Hose, Pressure Regulating Valve, Heavy Duty Filter, Safety Valve, Foot Operated Valve, High Pressure Gun, Nozzles, Lances: Rigid & Flexible, Sand Blasting Attachments.

CONDENSOR TUBE CLEANING



BEFORE CLEANING

AFTER CLEANING

WATER BLASTING



CONDENSOR CLEANING



High Pressure Pump, fitted with Unloader & Safety Valve is driven by electric motor or diesel engine and assembled with Centrifugal Pump filter to ensure supply of pressurized clean water at Pump Inlet. Complete pump unit with local Control Panel, Instrumentation and Safety Controls is mounted on a vibration free fixed base frame or movable trolley with solid wheels. Overhead water tank can also be fixed on frame. Complete unit can also be manufactured suitable for operation in hazardous area with flameproof electrics. Our Pump having Solid Ceramic Plunger & Cooling system which increases the life cycle of Plunger & Seals. Also Provide Oil Cooling system on request.

TECHNICAL SPECIFICATIONS

SJ SERIES - 10000 PSI (750 BAR) Pump

Pump Model	Plunger Dia (mm)	Flow Rate (lpm)	Crank Shaft speeds 530 Minute with 1450 RPM Electric Motor	
			60 HP	75 HP
SJ-20	20	35	620	750
SJ-22	22	42	520	680
SJ-24	24	52	430	530
SJ-26	26	62	360	450
SJ-28	28	70	310	375
SJ-30	30	80	270	330
SJ-32	32	90	240	300
SJ-36	36	115	190	230

VM SERIES - 15000 PSI (1000 BAR) Pump

Pump Model	Plunger Dia (mm)	Flow Rate (lpm)	Crank Shaft speeds 435 Minute with 1450 RPM Electric Motor		
			100 HP / 75	120 HP / 90 KW	150 HP / 110 KW
VM-20	20	38	950	1200	1300
VM-22	22	47	800	950	1000
VM-24	24	56	650	800	950
VM-26	26	65	550	700	800
VM-28	28	76	480	600	700
VM-30	30	87	410	500	600
VM-32	32	99	375	450	525
VM-36	36	126	280	350	400

About - TRII-PLEX JETTECH SYSTEMS

--> ISO 9001:2015 & OHSAS 18001:2007 CERTIFIED COMPANY

--> Manufacturer of High Pressure Triplex Plunger Pumps- Up to 1400 Bar Pressure Range.

--> Authorized Dealer of SMC Jet India of High Pressure Equipments (Canadian Company) | URL- smcjet.com

--> We Deal in Stoneage tools & Equipments for High Pressure Pumps & Hydroblasting Equipments.

ACCESSORIES



HIGH PRESSURE DUMP GUN

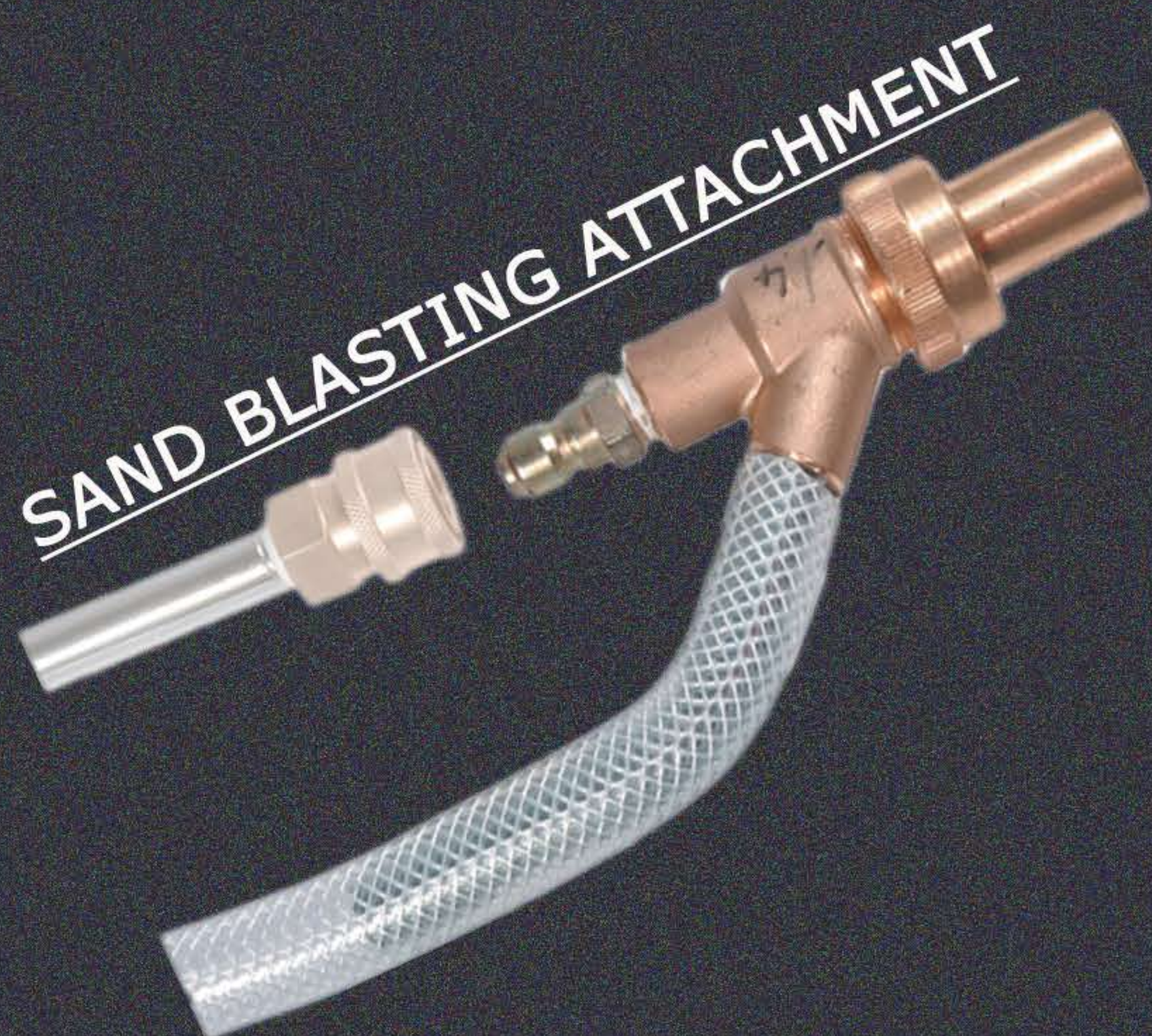

SAND BLASTING ATTACHMENT



STRAIGHT JET NOZZLE

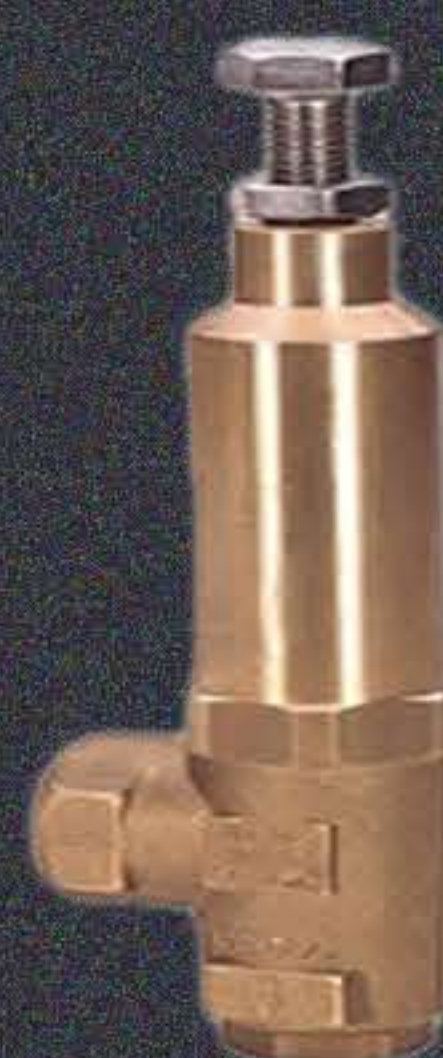

SAFETY VALVE



PRESSURE GAUGE



TUBE CLEANING NOZZLES



ROTATING NOZZLES



FOOT OPERATING VALVE



H.P. RUBBER HOSES



H.P. FLEXIBLE LANCES

VARIOUS TYPES OF SYSTEMS

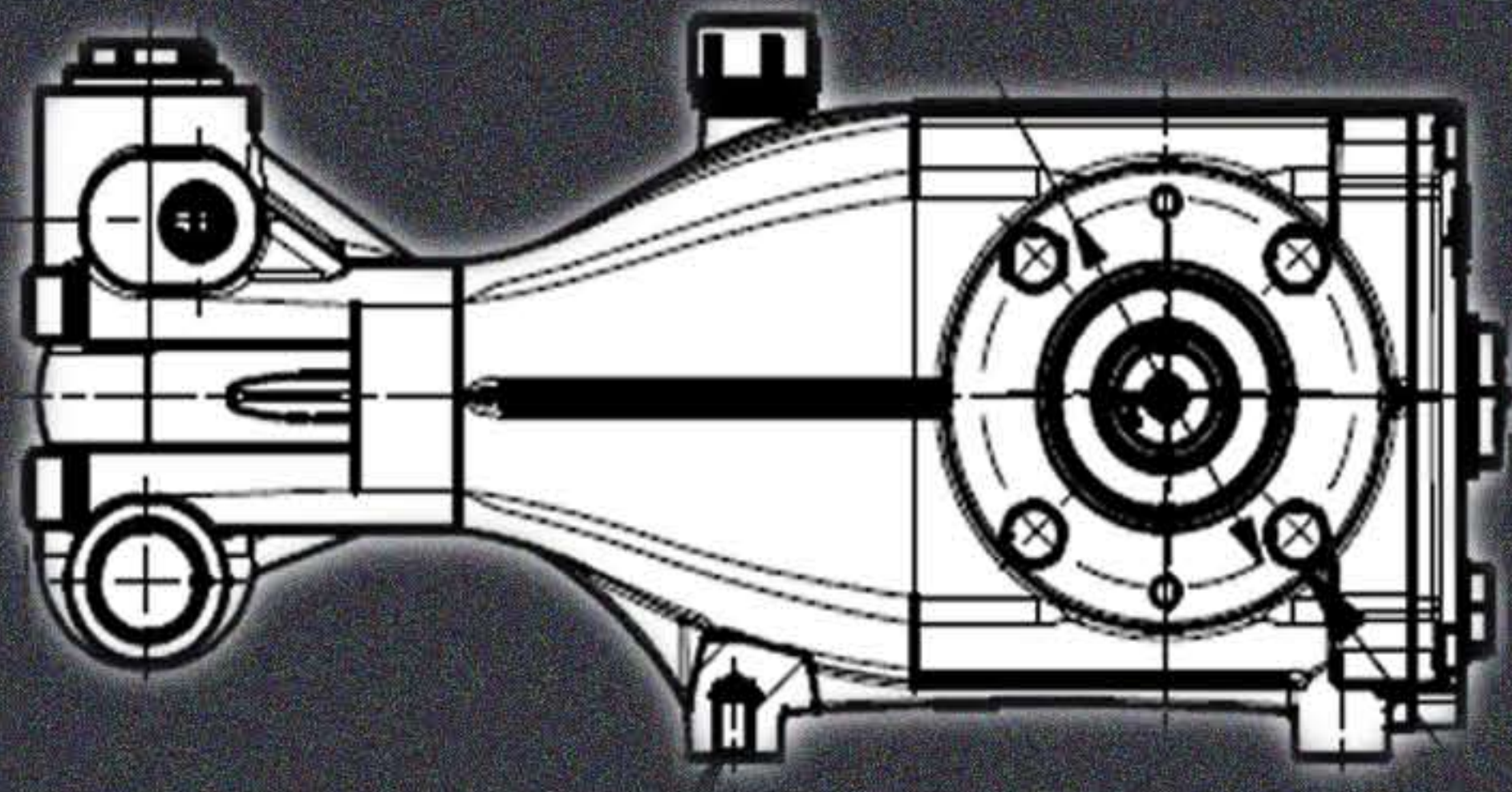

Hawk Series

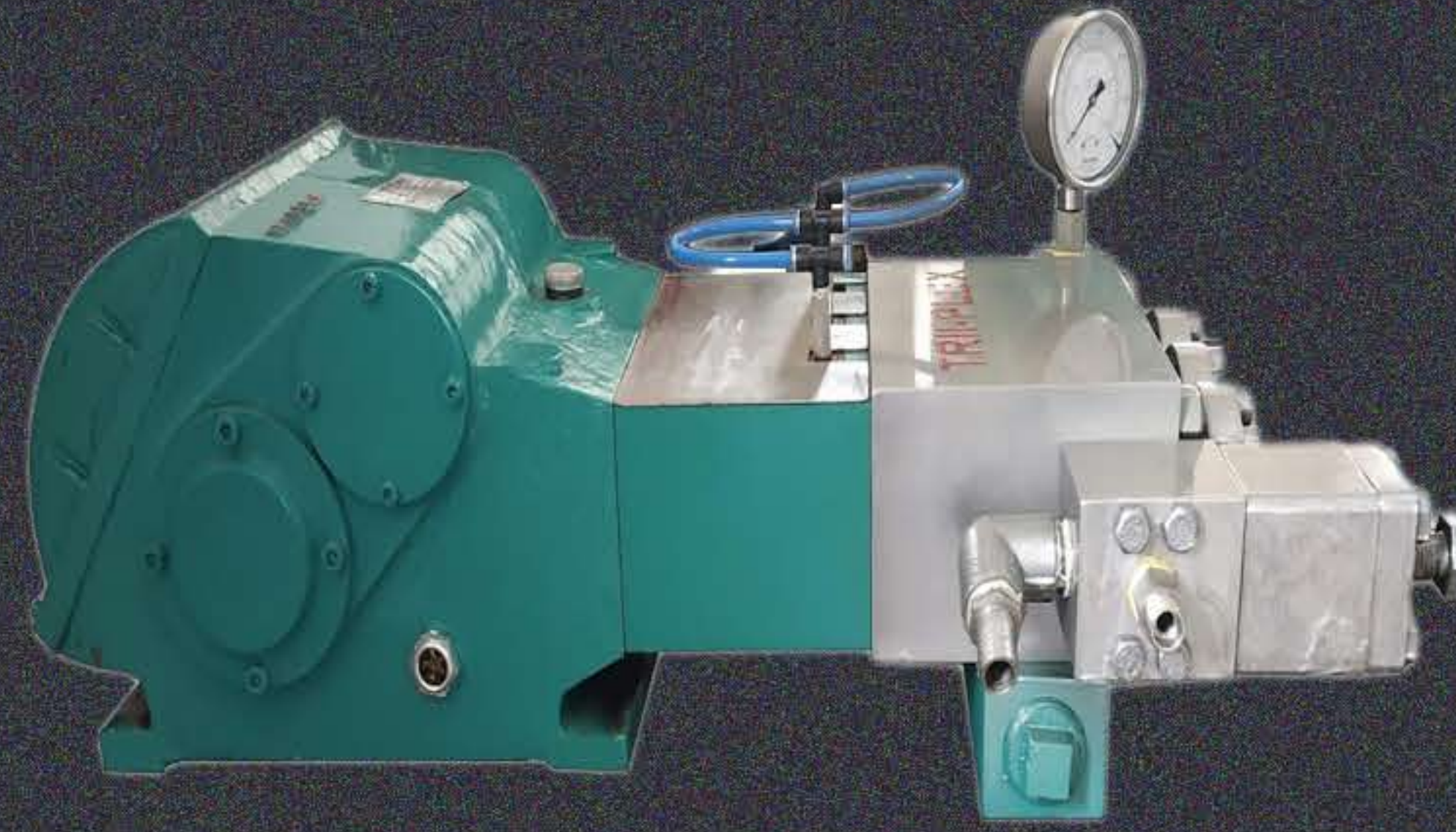
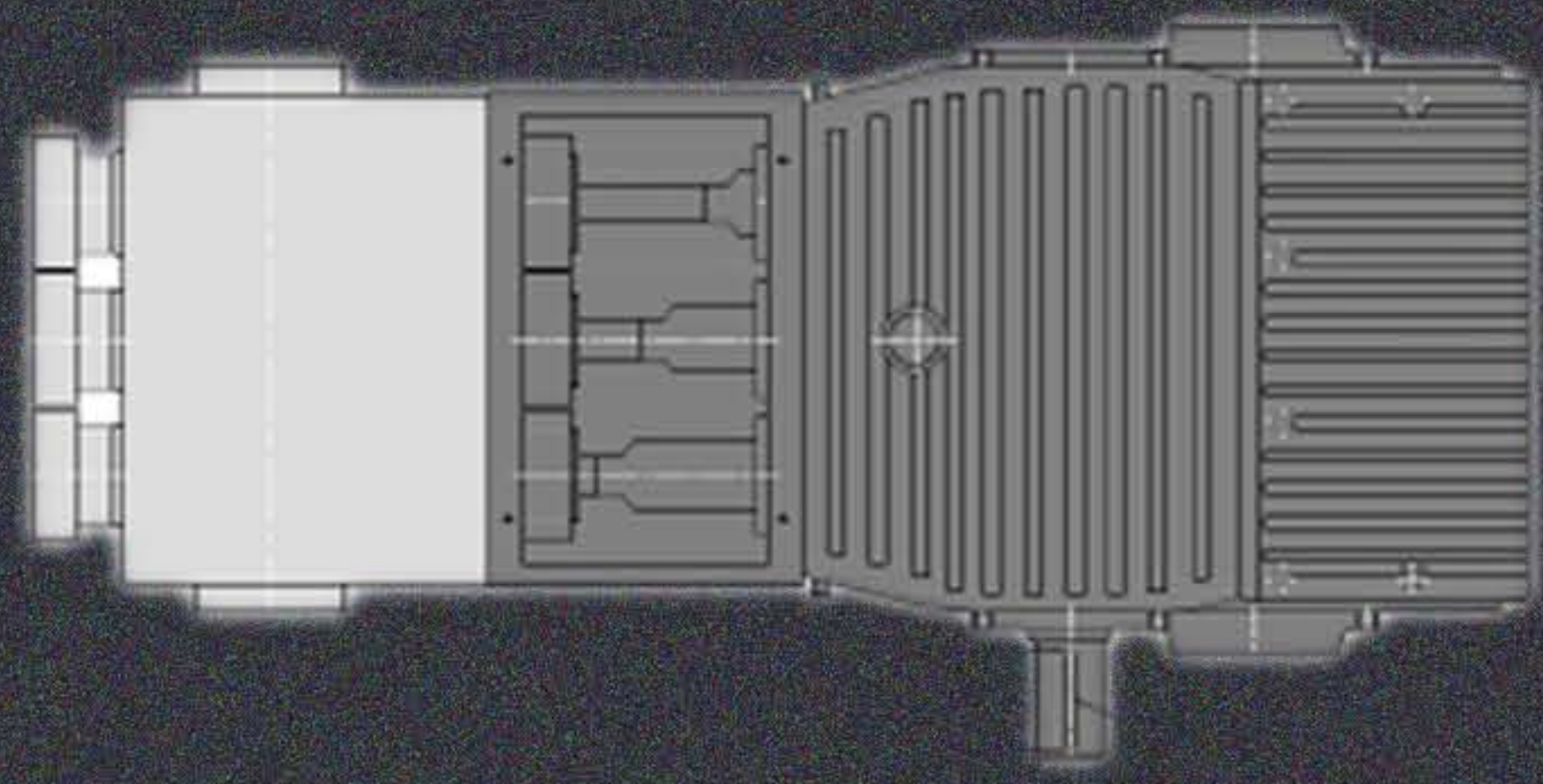

SJ Series

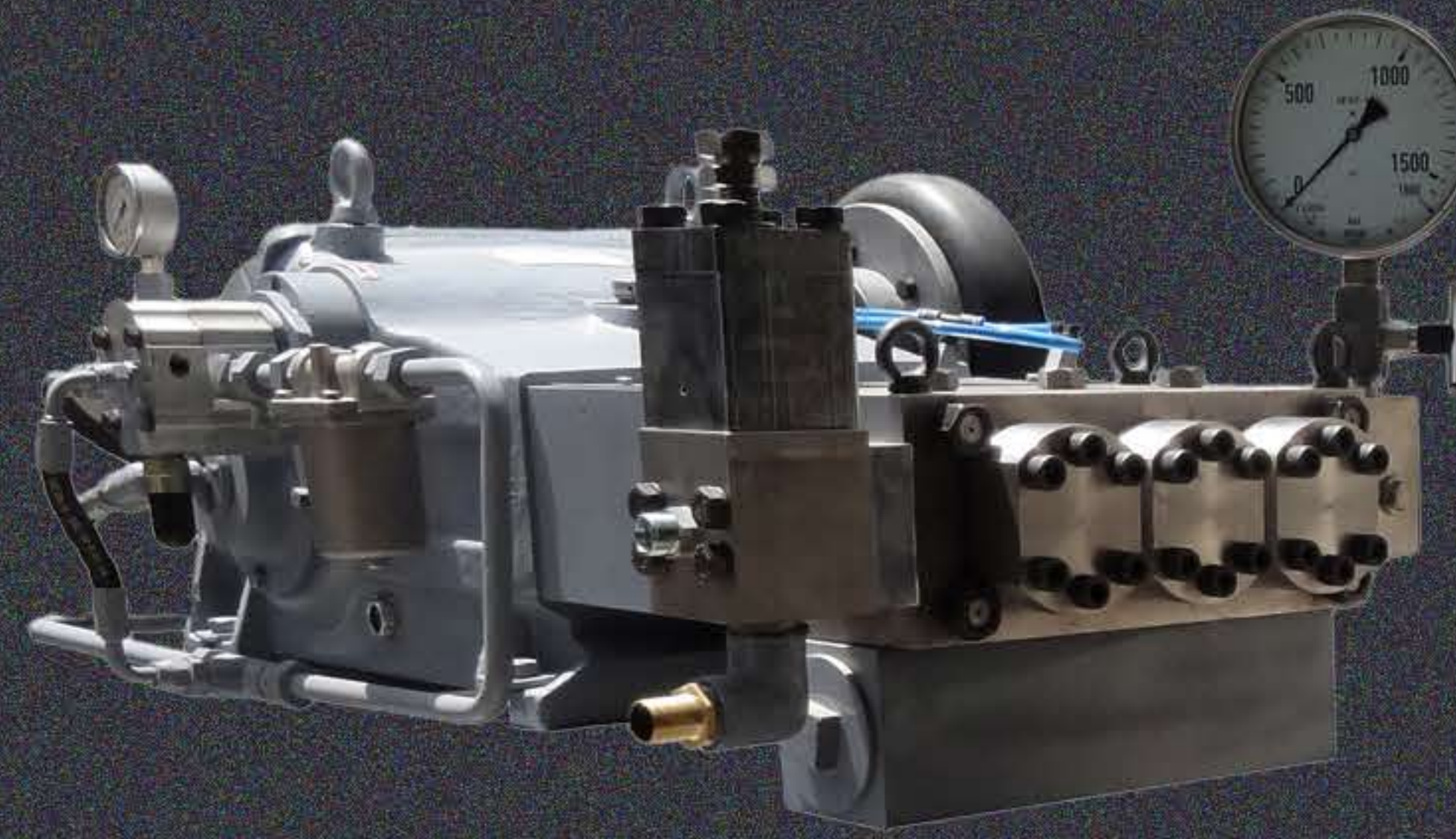
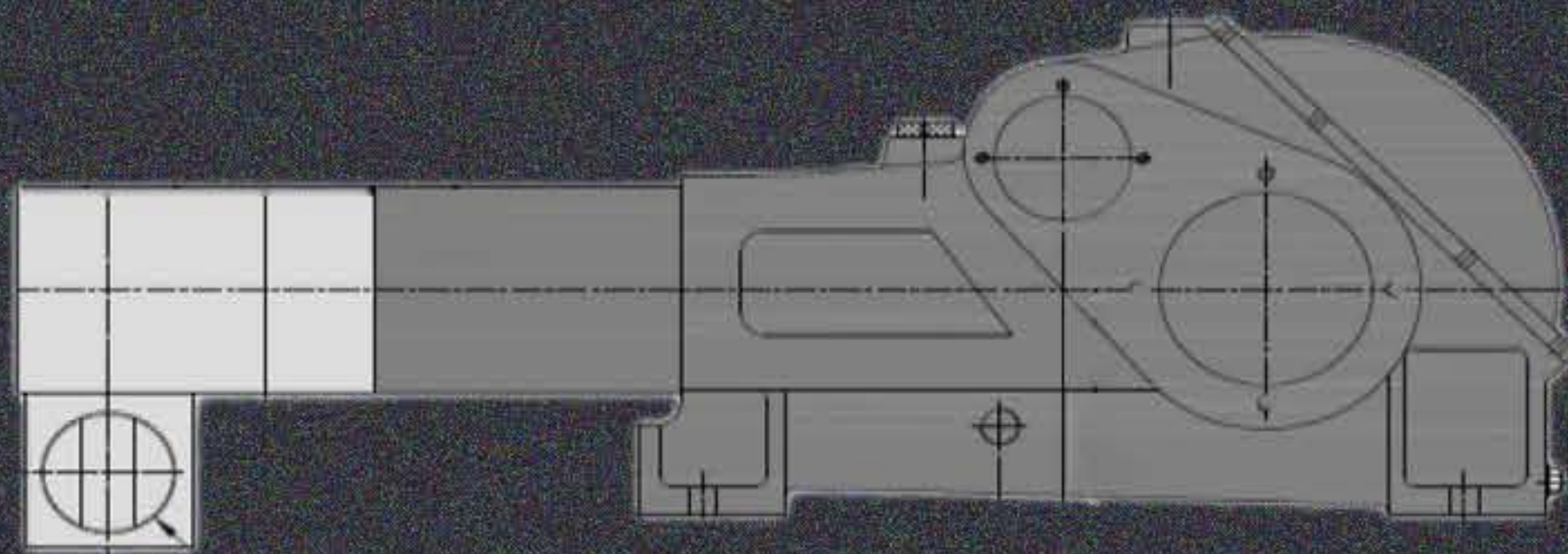

VM Series

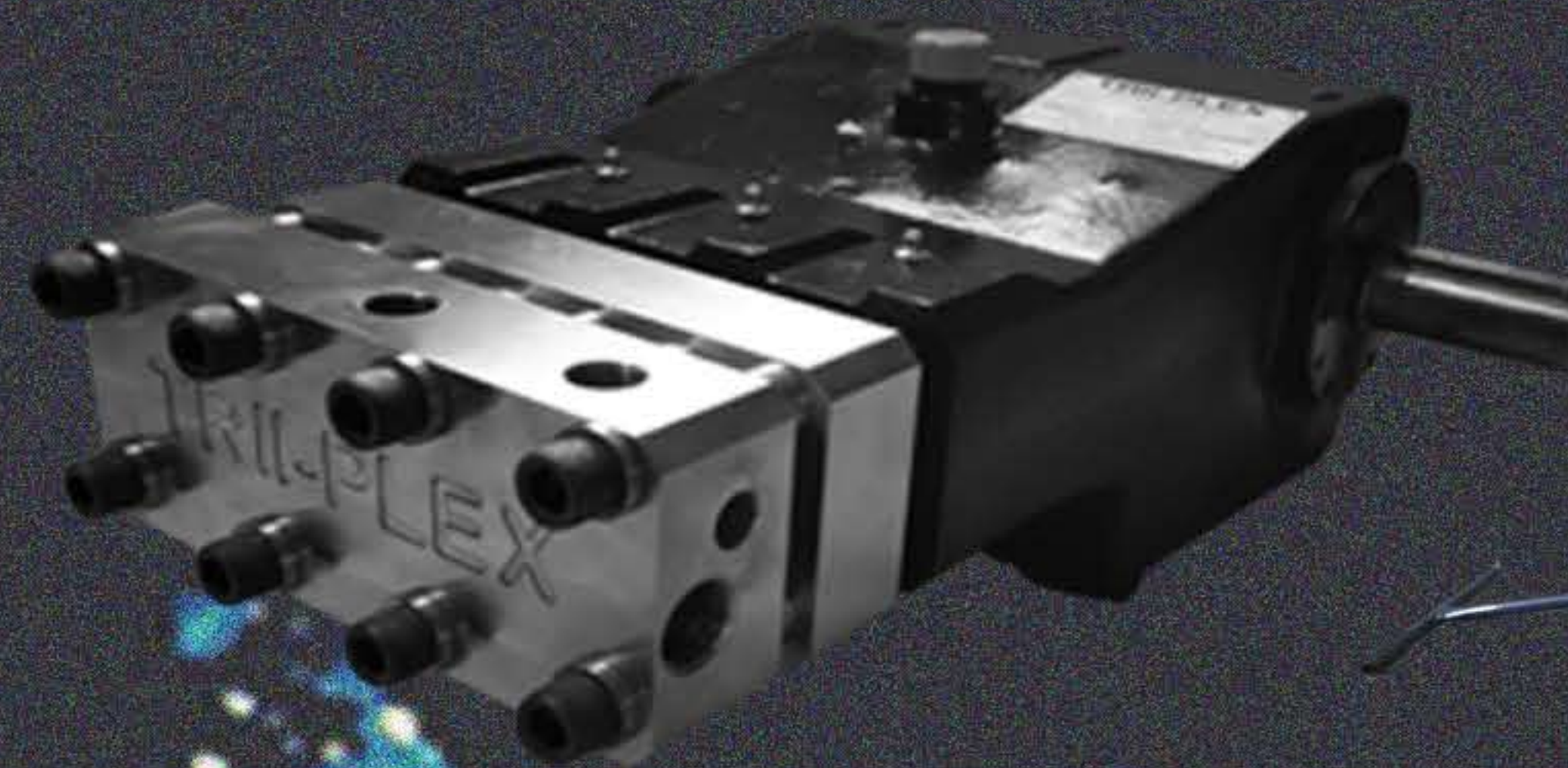
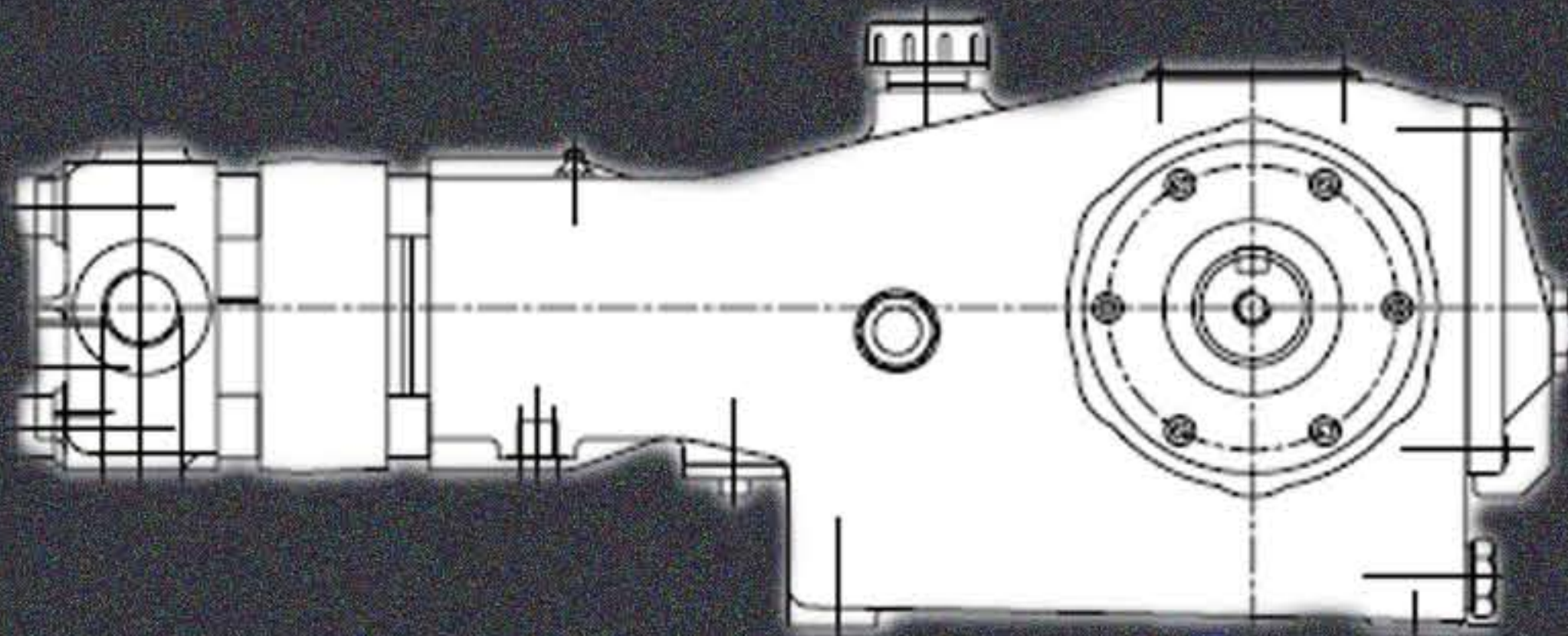
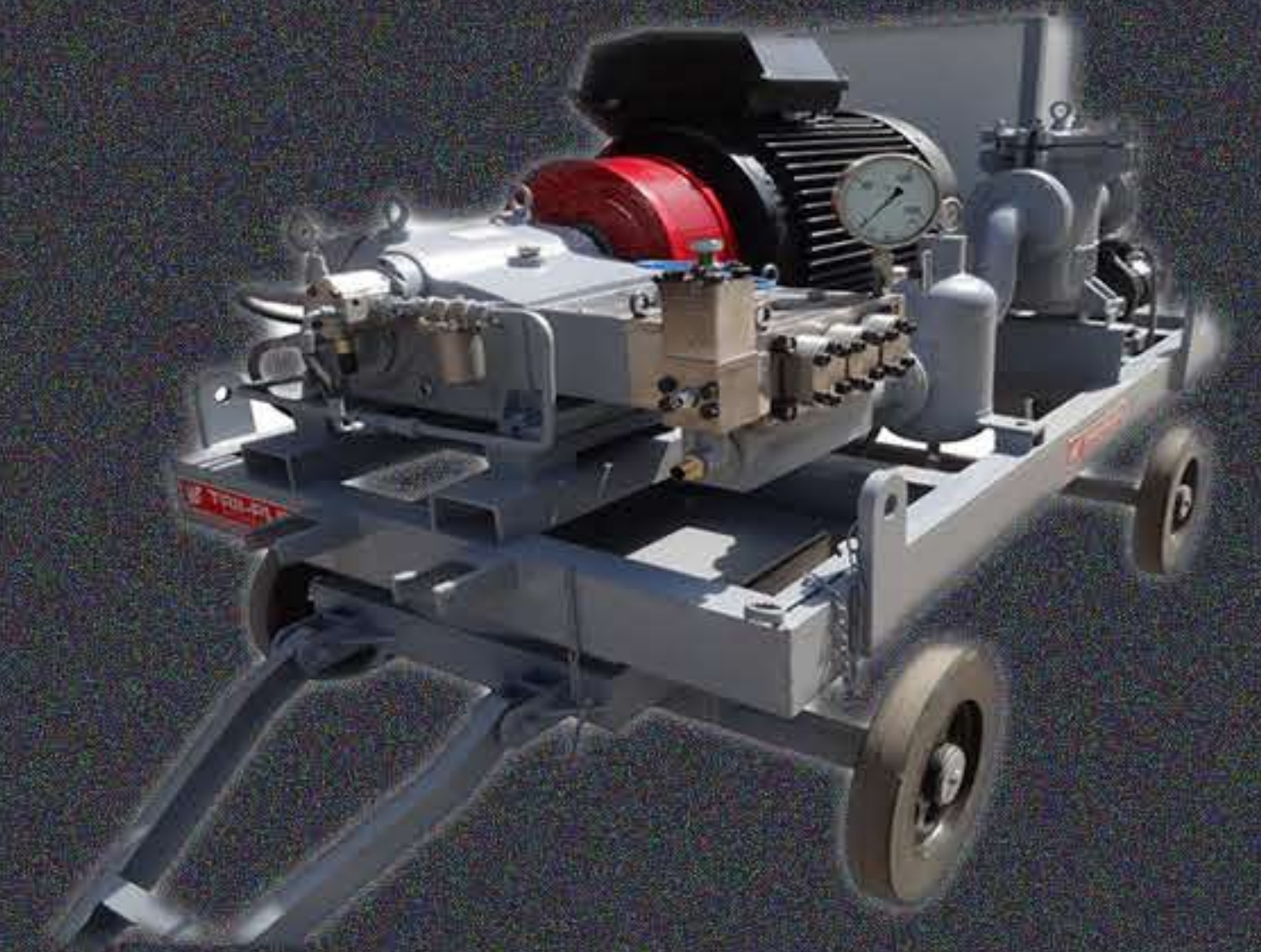

SP Series



TRII-PLEX
JETTECH SYSTEMS

TRII-PLEX JETTECH SYSTEMS

50, Vrundavan Ind. Estate, Ramol CTM Road, • Nr. Ramol Ring Road, Ramol A'bad- 382449

Cell No- 8000992352 | E-mail- triiplexjettechsystems@gmail.com

www.triiplexjettechsystems.com