

COPYRIGHT NOTICE :-
 THIS DRAWING IS COPYRIGHT AND MAY NOT BE REPRODUCE, WHOLLY OR IN PART,
 WITHOUT PRIOR WRITTEN CONSENT OF THE TRII-PLEX JETTECH SYSTEMS.
 Mr. VIMAL PATEL :- 7878522352.
 E-MAIL:- triiPLEXJETTECHSYSTEMS@gmail.com

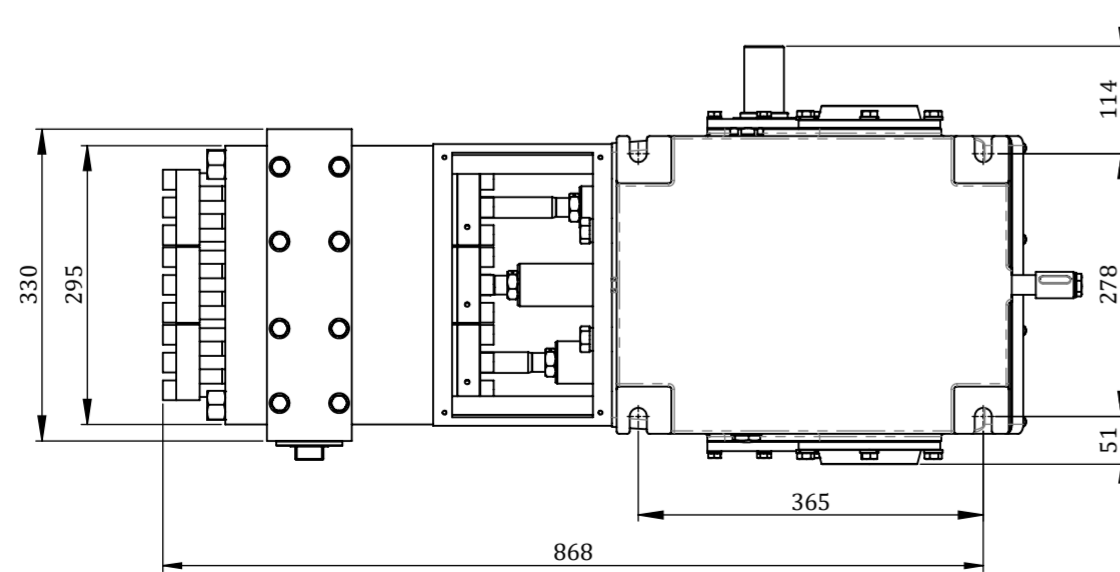
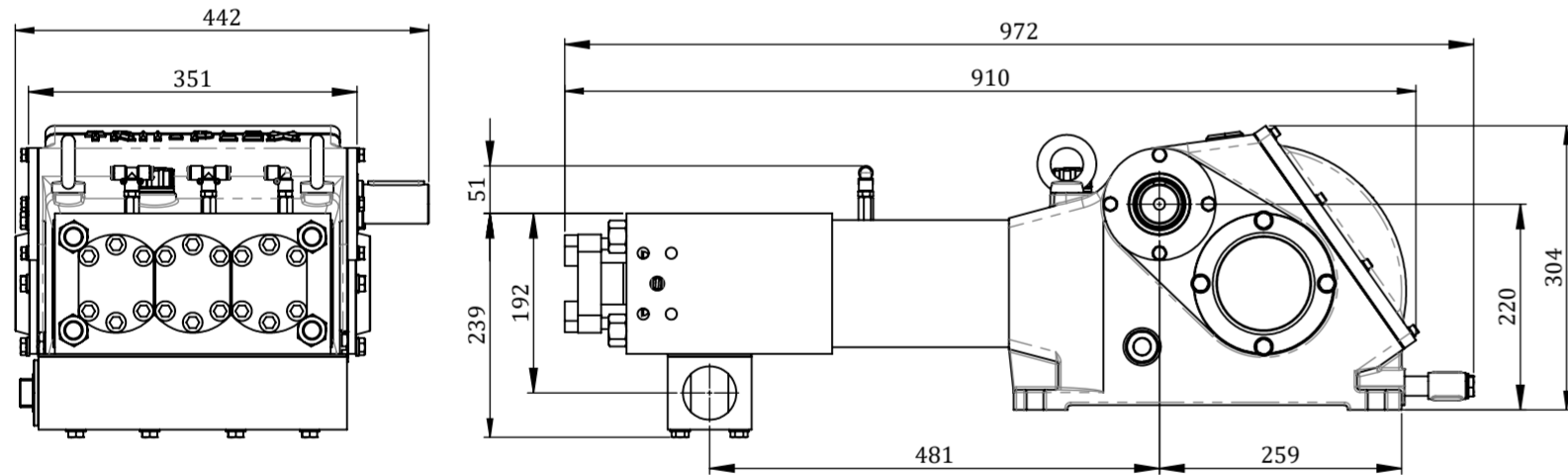
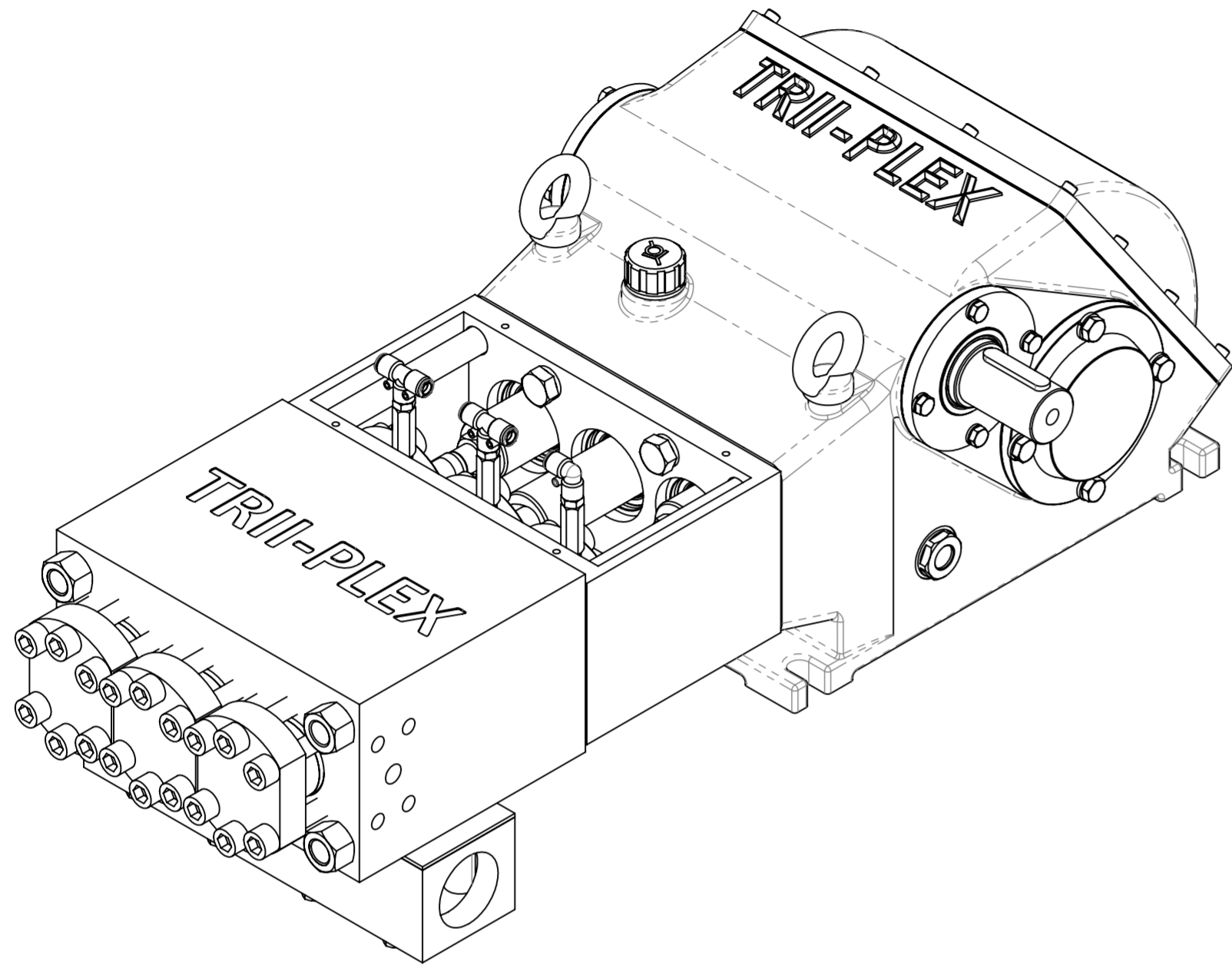

ITEM NO.	DESCRIPTION	QTY.
1	SJ-Crank Case	1
2	SJ-Crank Case Cover Gasket	1
3	SJ-Crank Case Cover	1
4	Spring Washer M6	12
5	H.T. Cap Screw M6x30	12
6	SJ-Crosshead Assembly	3
7	SJ-Piston Pin	3
8	Circlip_B-26	6
9	SJ-Connecting Rod Bottom	3
10	SJ-Bush For Connecting Rod	3
11	SJ-Connecting Rod Top	3
12	SJ-White Metal Bearing	3
13	SJ-Spring Washer For Connecting Rod	6
14	SJ-Connecting Rod Screw	6
15	SJ-Crank Shaft	1
16	SJ-Gear R.H.	1
17	SJ-Gear L.H.	1
18	SJ-Pinion Shaft	1
19	Spherical Roller Bearing 21310 E	2
20	SJ-Crankshaft Bearing Cover Gasket	2
21	SJ-Crankshaft Bearing Cover	2
22	Spring Washer M10	8
23	H.T. Hex Bolt M10x25	8
24	Cylindrical Roller Bearing NU-2210	2
25	SJ_VM-Piniun Shaft Bearing Cover_Gasket	2
26	SJ_VM-Piniun Shaft Bearing Cover_Blind	1
27	SJ_VM-Piniun Shaft Bearing Cover_Open	1
28	Circlip_A-50	2
29	Spring Washer M8	8
30	H.T. Hex Bolt M8x25	8
31	SJ-Piniun Shaft_Key 12x12x60mm.	1
32	SJ_VM-Oil Seal 65x50x8mm.	1
33	SJ_VM-Oil Seal 60x45x10mm.	3
34	SJ-Oil Seal Cover	3
35	SJ-O Ring 66x2.5	3
36	Oil Leval Indicator-3/4" BSP	1
37	Drain Plug-3/4" BSP	1
38	Nipple-1/2" BSP	1
39	Coupling-1/2" BSP	1
40	Drain Magnetic Plug-1/2" BSP	1
41	Breather Plug-3/4" BSP	1
42	Eye Bolt M16x25	2
43	SJ-Carrier	1
44	Spring Washer M16	4
45	H.T. Hex Bolt M16x45	4
46	Dowel Pin 10x20mm.	2
47	SJ-Stud	4
48	H.T. Hex Nut M20	4
49	SJ-Pump Head	1
50	SJ-Suction Manifold Gasket	1
51	SJ-Suction Manifold	1
52	SS Plain Washer M10	8
53	H.T. Hex Bolt M10x90	8

ITEM NO.	DESCRIPTION	QTY.	
54	SJ-Suction Plug	1	
55	SJ-Stuffing Box_18mm.	3	
	SJ-Stuffing Box_20mm.		
	SJ-Stuffing Box_22mm.		
	SJ-Stuffing Box_24mm.		
56	SJ-Stuffing Box_26mm.	3	
	SJ_VM-Inner Brass Ring 18mm.		
	SJ_VM-Inner Brass Ring 20mm.		
	SJ_VM-Inner Brass Ring 22mm.		
	SJ_VM-Inner Brass Ring 24mm.		
	SJ_VM-Inner Brass Ring 26mm.		
57	SJ_VM-18mm Plunger Seal	3	
	SJ_VM-20mm Plunger Seal		
	SJ_VM-22mm Plunger Seal		
	SJ_VM-24mm Plunger Seal		
	SJ_VM-26mm Plunger Seal		
58	SJ_VM-Outer Brass Ring 18mm.	3	
	SJ_VM-Outer Brass Ring 20mm.		
	SJ_VM-Outer Brass Ring 22mm.		
	SJ_VM-Outer Brass Ring 24mm.		
	SJ_VM-Outer Brass Ring 26mm.	3	
59	SJ_VM-O Ring 46x3		
	SJ_VM-O Ring 18x3		
	SJ_VM-O Ring 20x3		
	SJ_VM-O Ring 22x3		
60	SJ_VM-O Ring 24x3	3	
	SJ_VM-O Ring 26x3		
61	SJ-O Ring 8x2	3	
62	SJ-Ceramic Plunger 18mm.	3	
	SJ-Ceramic Plunger 20mm.		
	SJ-Ceramic Plunger 22mm.		
	SJ-Ceramic Plunger 24mm.		
	SJ-Ceramic Plunger 26mm.	36	
63	H.T. Cap Screw M14x70		
64	SJ_VM-Colling Nipple		3
65	1/8"x8mm Tee		2
	1/8"x8mm Elbow		1
66	SJ_VM-P.O.M Gasket	9	
67	SJ_VM-O Ring 54x3	9	
68	SJ_VM-Discharge Valve Guide	3	
69	SJ_VM-Discharge Spring Guide	3	
70	SJ_VM-Discharge Spring	3	
71	SJ_VM-Discharge Valve	3	
72	SJ_VM-Suction & Discharge Valve Seat	3	
73	SJ_VM-Suction Valve	3	
74	SJ_VM-Suction Spring	3	
75	SJ_VM-Suc. Spring Guide	3	
76	SJ-Suction Sleeve-18mm.	3	
	SJ-Suction Sleeve-20mm.		
	SJ-Suction Sleeve-22mm.		
	SJ-Suction Sleeve-24mm.		
	SJ-Suction Sleeve-26mm.	3	
77	SJ-Valve Seat Holder		

REMARKS 1. ALL DIMENSIONS ARE IN MM. 2. UNSPECIFIED ALL CHAM. ARE 1x45°. 3. * MARKED DIMENSIONS TO BE CHECKED THOROUGHLY. 4. PLEASE REMOVE ALL BURRS. 5. UNSPECIFIED ALL TOLERANCE OF DIM. ARE ±0.10mm.	DESIGN ACTIVITY			TRII-PLEX JETTECH SYSTEMS 50, VRUNDAVAN INDUSTRIAL ESTATE, RAMOL-CTM ROAD, AHMEDABAD-382449	
	NAME	SIGN.	DATE	TITLE :- SJ-PUMP MANUFACTURING PROCESS CHART	
	DRN.	KEVAL	13.6.17		
	CHK.	SAMIR			
	APPR.	SAMIR		FINISHING :- ▽ ▽ ▽ GRINDING :- ▽ ▽ ▽	
SCALE	:- 1 : 1		R.M. SIZE :- N.A.		
QUANTITY	:- N.A.		REF. DRG NO. :- N.A.		
MATERIAL	:- N.A.				
FINISH WT.	:- N.A.				
ROUGH WT.	:- N.A.				
CATEGORY	SHEET SIZE	PART NO. :-	DRAWING NO. :-	SHEET NO. :-	REV.
DETAIL	A2	N.A.	N.A.	02 OF 01	R0

M/C. DEVIATION FOR LINEAR AS PER ISO 2768-M								
DIMN.	OVER	0.5	6	30	120	400	1000	2000
	UP TO	6	30	120	400	1000	2000	4000
TOLERANCE		±0.1	±0.2	±0.3	±0.5	±0.8	±1.2	±2

COPYRIGHT NOTICE :-
 THIS DRAWING IS COPYRIGHT AND MAY NOT BE REPRODUCE, WHOLLY OR IN PART,
 WITHOUT PRIOR WRITTEN CONSENT OF THE TRII-PLEX JETTECH SYSTEMS.
 Mr. VIMAL PATEL :- 7878522352.
 E-MAIL:- triiplexjettechsystems@gmail.com

REVISION TABLE					
REV. No.	DATE	DESCRIPTION	DRN. BY	CHK. BY	APPR. BY

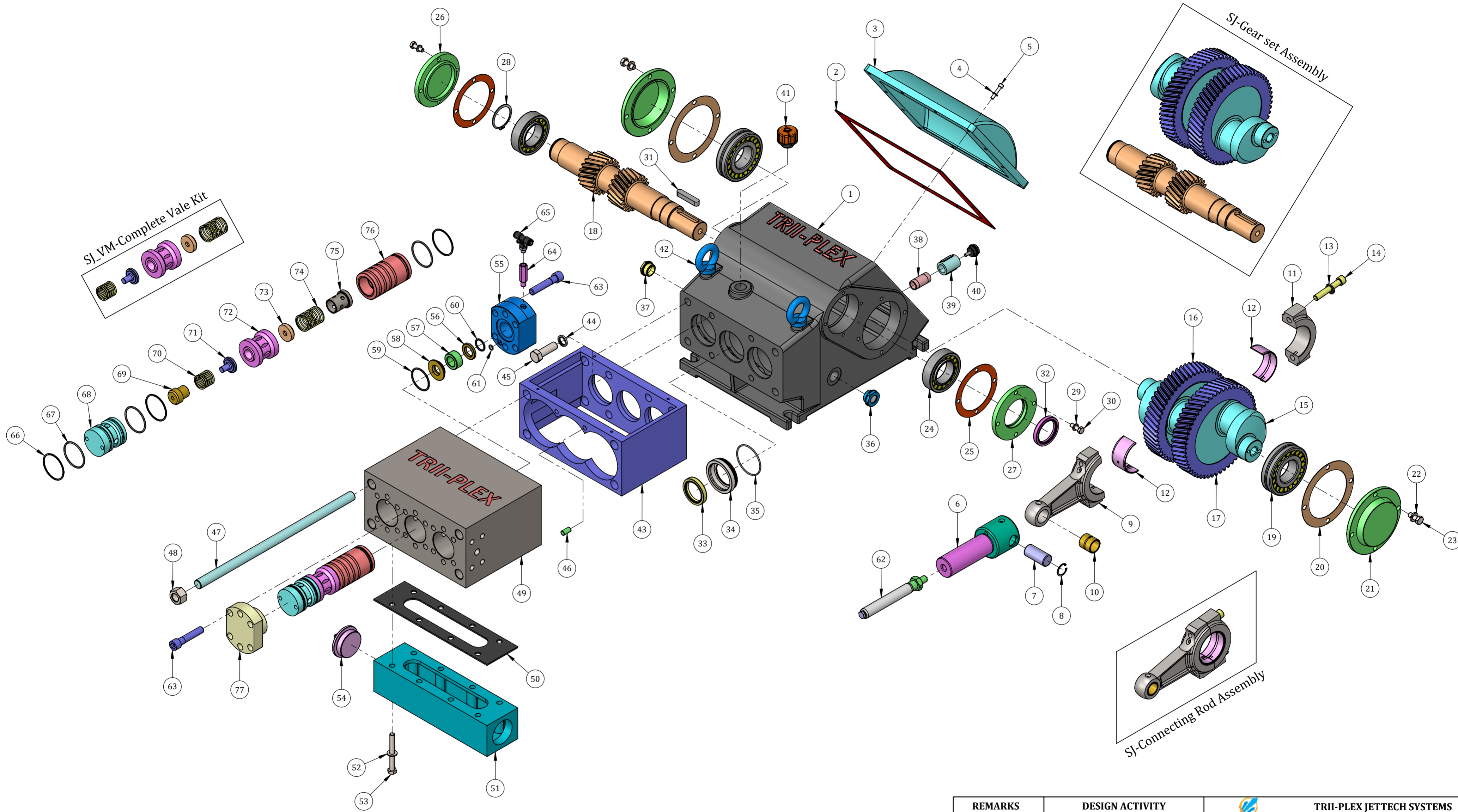

M/C. DEVIATION FOR LINEAR AS PER ISO 2768-M								
DIMN.	OVER	0.5	6	30	120	400	1000	2000
	UP TO	6	30	120	400	1000	2000	4000
TOLERANCE		±0.1	±0.2	±0.3	±0.5	±0.8	±1.2	±2

REMARKS	DESIGN ACTIVITY			TRII-PLEX JETTECH SYSTEMS				
	NAME	SIGN.	DATE	50, VRUNDAVAN INDUSTRIAL ESTATE, RAMOL-CTM ROAD, AHMEDABAD-382449				
	1. ALL DIMENSIONS ARE IN MM.	DRN.	KEVAL	13.6.17	TITLE :-			
	2. UNSPECIFIED ALL CHAM. ARE 1x45°.	CHK.	SAMIR		SJ-PUMP			
3. * MARKED DIMENSIONS TO BE CHECKED THOROUGHLY.	APPR.	SAMIR		MANUFACTURING PROCESS CHART				
4. PLEASE REMOVE ALL BURRS.	SCALE	:- 1 : 1			QUANTITY	:- N.A.		
5. UNSPECIFIED ALL TOLERANCE OF DIM. ARE ±0.10mm.	MATERIAL	:- N.A.			FINISHING	:- ∇∇		
	FINISH WT.	:- N.A.			R.M. SIZE	:- N.A.		
	ROUGH WT.	:- N.A.			REF. DRG NO.	:- N.A.		
	CATEGORY	SHEET SIZE	PART NO. :-	DRAWING NO. :-	SHEET NO. :-	REV.		
	DETAIL	A2	N.A.	N.A.	02 OF 02	R0		

COPYRIGHT NOTICE :-
 THIS DRAWING IS COPYRIGHT AND MAY NOT BE REPRODUCE, WHOLLY OR IN PART,
 WITHOUT PRIOR WRITTEN CONSENT OF THE TRII-PLEX JETTECH SYSTEMS.
 Mr. VIMAL PATEL :- 7878522352.
 E-MAIL:- triiplexjettechsystems@gmail.com

REVISION TABLE					
REV. No.	DATE	DESCRIPTION	DRN. BY	CHK. BY	APPR. BY

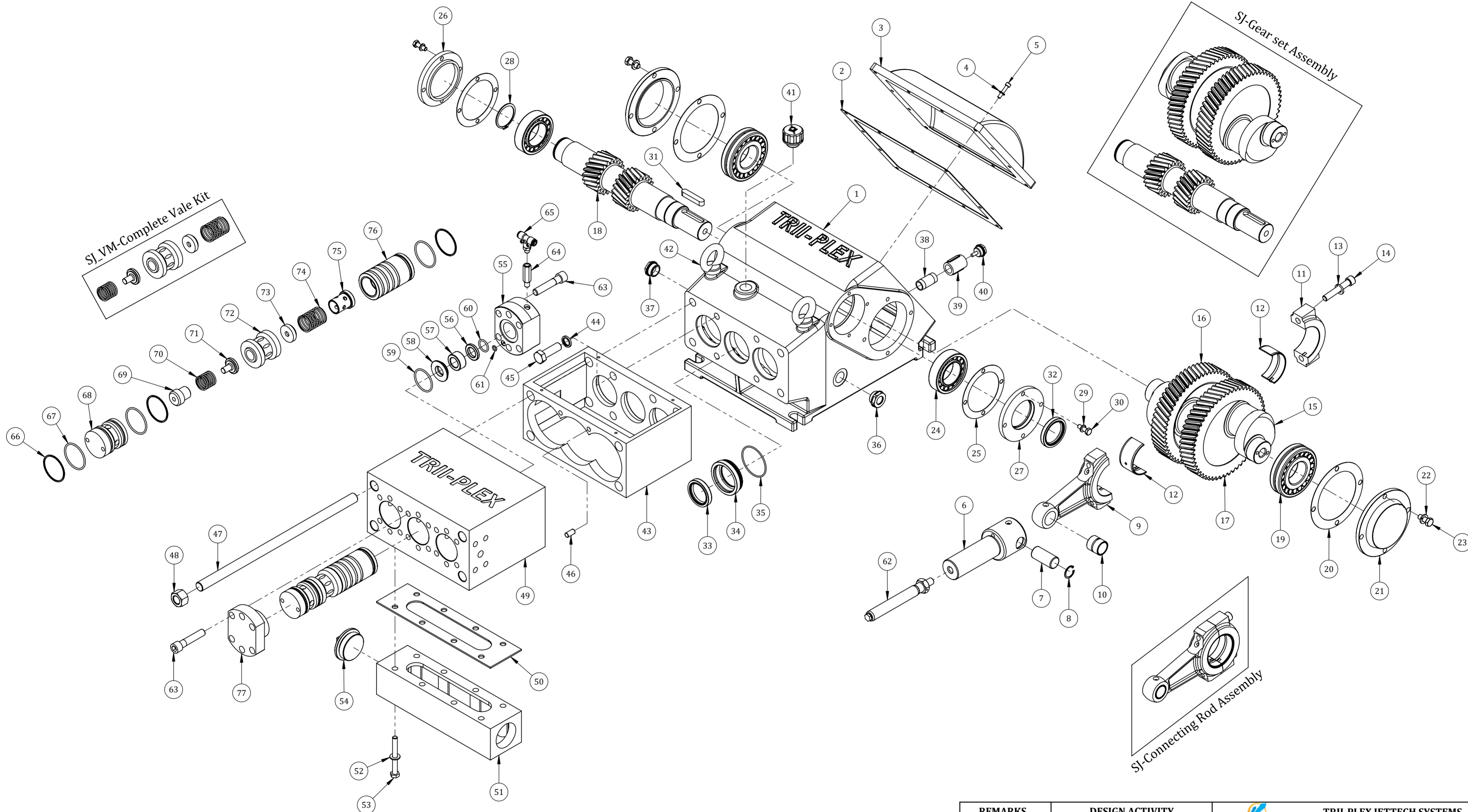

M/C. DEVIATION FOR LINEAR AS PER ISO 2768-M								
DIMN.	OVER	0.5	6	30	120	400	1000	2000
	UP TO	6	30	120	400	1000	2000	4000
TOLERANCE		±0.1	±0.2	±0.3	±0.5	±0.8	±1.2	±2

REMARKS	DESIGN ACTIVITY			TRII-PLEX JETTECH SYSTEMS					
	NAME	SIGN.	DATE	50, VRUNDAVAN INDUSTRIAL ESTATE, RAMOL-CTM ROAD, AHMEDABAD-382449					
	1. ALL DIMENSIONS ARE IN MM.	DRN. KEVAL		13.6.17	TITLE :- SJ-PUMP MANUFACTURING PROCESS CHART QUANTITY :- N.A. FINISHING :- ▽▽ GRINDING :- ▽▽▽ MATERIAL :- N.A. R.M. SIZE :- N.A. FINISH WT. :- N.A. REF. DRG NO. :- N.A. ROUGH WT. :- N.A.				
	2. UNSPECIFIED ALL CHAM. ARE 1x45°.	CHK. SAMIR							
3. * MARKED DIMENSIONS TO BE CHECKED THOROUGHLY.	APPR. SAMIR								
4. PLEASE REMOVE ALL BURRS.	SCALE :- 1 : 1			CATEGORY	SHEET SIZE	PART NO. :-	DRAWING NO. :-	SHEET NO. :-	REV.
5. UNSPECIFIED ALL TOLERANCE OF DIM. ARE ±0.10mm.				DETAIL	A2	N.A.	N.A.	02 OF 02	R0