

# Shredder Tooling

Shredder Machine Rotary Blades, Shredder Machine Shafts,  
Plastic, Aluminum, Rubber Shredding Blades & Components

*www.apexshears.com*



Apex Shears is a global specialist in the manufacture of a wide range of Knives, Blades and Tools for the Plastics Shredding, Waste Shredding, Aluminum Can Shredding and other Metal Recycling Operations.

The world-class durability and productivity of Apex Shears is based on decades of experience and cooperation with customers. Apex's quality is based on state-of-the-art production facilities equipped with the most modern and advanced machines and equipment coupled with over 55 years of accumulated know-how & research.

We leave nothing to chance!

**The salient features of Apex Shears' Knives, Blades and Components are:**

- **All Products are manufactured from the finest quality steels available sourced from a net work of worldwide suppliers ensuring consistent quality.**
- **Digitally Controlled Advanced Heat treatment.**
- **High Wear Resistance, Durability and Impact Strength.**
- **Precision ground Surface, Sharp and Straight Cutting edges.**
- **High Performance, Lower Machine Downtime, Greater Productivity Tooling.**
- **High quality surface finish.**

**We just don't make the tool, but offer the "Total Tooling Solution"**



# For Plastics/Rubber/Aluminum

- **Rotary Shredder Knives for Plastic Shredding**
- **Shredder Knives for Aluminum Shredding**
- **Shredding Knives for TDF (Tyre Derived Fuel)**
- **Shredder Knives for Rubber Mulch, Rubber Tyres with Steel Cords**
- **Shredder Knives for Crumb Rubber & Rubber Powder**
- **Specialized Shredding Knives for your application**

For our Plastics, Aluminum, Rubber Shredding/Recycling Knives and Wear Parts, we start with selection of the finest high quality steel grades that are selected with great accuracy. These steel grades range from tough medium alloy tool steels to long life high carbon high chrome steels and special high wear resistant steel grades.

Our Steel Grades for these Shredding Knives ranges from Carbon Steel 9Cr-Si to alloy steel 42CrMo and also to High Alloy Tool Steel AISI D2/SKD11 Grade Steel.

Our experienced engineers select the knife material on the basis of your machines/equipment and the material being cut. Our Heat Treatment processes and Through-Hardening Techniques have been perfected with over 55 years of manufacturing experience to enhance the strength, durability and performance of our knives.

Thereafter these knives are ground using superior grinding machines and techniques to give a proper surface finish, clean sharp cutting edge for durability, performance and superior shred quality.

We also manufacture shafts for single shaft/double shaft designs for the shredding machines as well as the metal spacers that may be required by our customers.

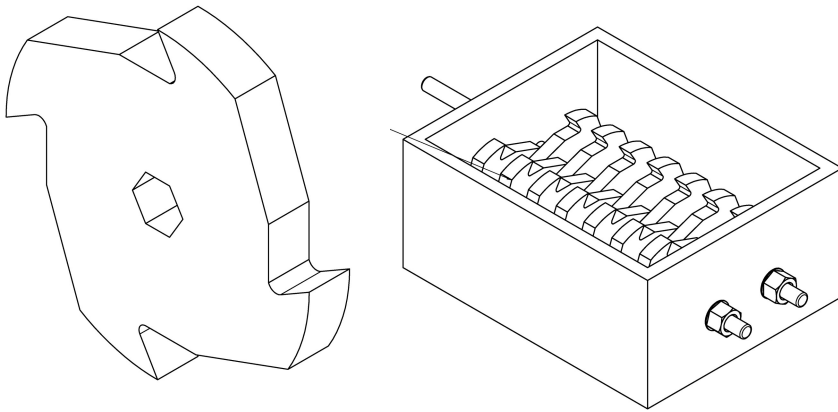

ISOMETRIC VIEW

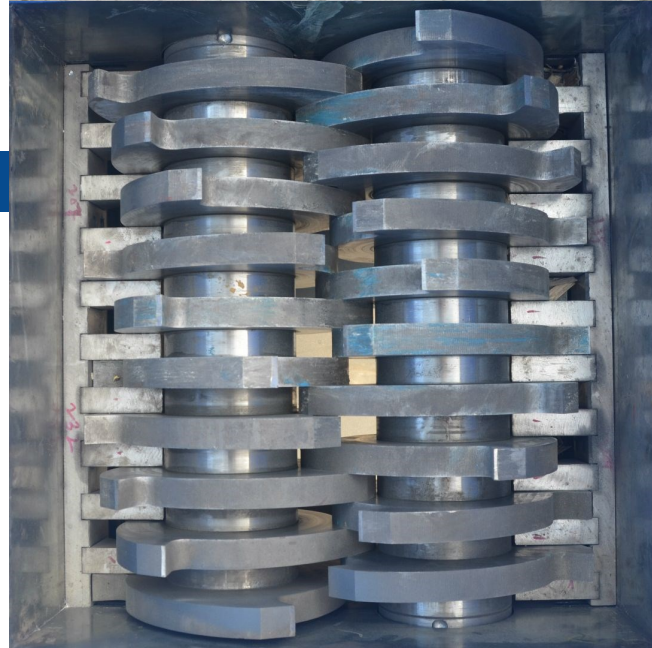
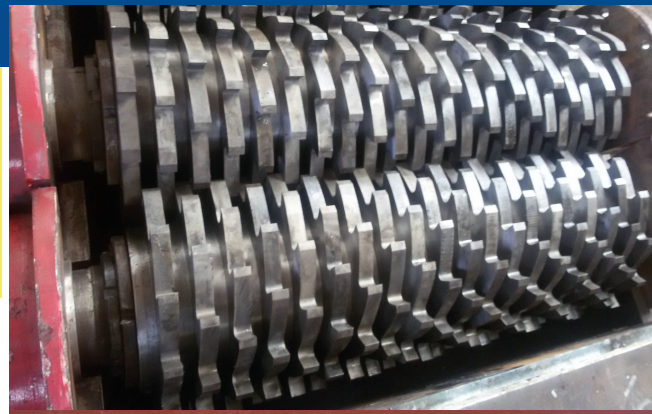

## Total Cutting Solutions..

The productivity and quality of end products are directly affected by the cutting tool performance. Yield, quality and production speed optimization present key challenges for Modern Plants and Processing & Recycling Facilities

- Continuous productivity pressure demands greater performance from Tooling which has to meet the challenge.
- This is met through Higher Quality and more durable, efficient Knives, Blades and Tools that are able to work under the toughest conditions.
- Knives have to retain their sharpness and edge toughness for as long as possible to maximize useful life and increase replacement intervals.

At Apex we have risen to the challenge and are looking into the future and look forward to meeting you there!. We just don't offer the tool but the "Total Cutting Solution" for our customers!



**apex shears pvt. ltd**  
*The Total Tooling Solutions Company!*

Works : Khasra No 1029/1040, Central Hopetown, Selaqui Indl Area, Dehradun 248011. Uttarakhand  
Tel : +91-7830071500, 7830007783.  
Email : info@apexshears.com  
Internet : www.apexshears.com