

ALS INDUSTRIES

DYEING MACHINES

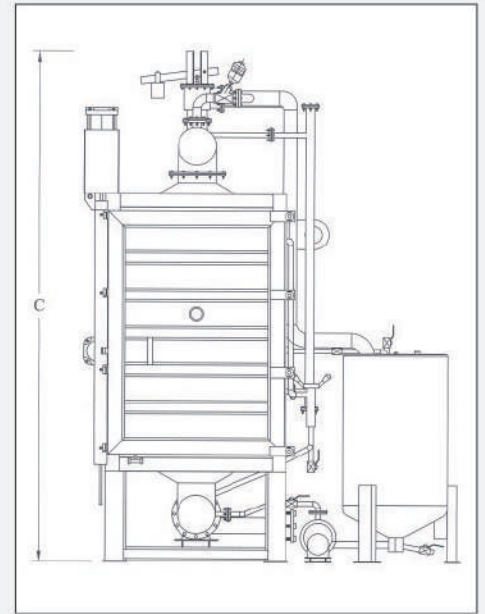

TUBRO TYPE - PRESSURE DYEING MACHINE
FOR HANKS

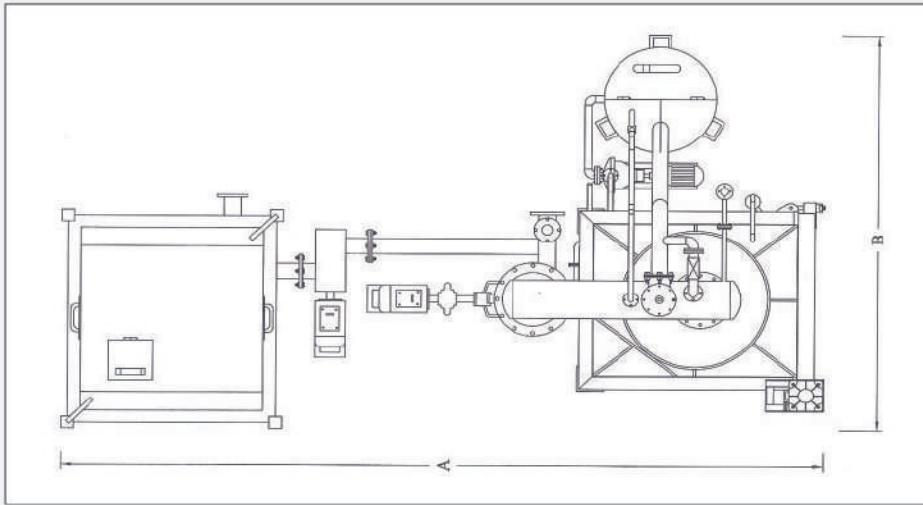

TECHNICAL DATA

Model	Capacity	Steam Consumption		Motor Capacity HP	Dimension (mm)		
		Qty. Kg/Hr.	Pressure Kg/Cm		A	B	C
ALS-10	10 Kg	25	5	5	2400	1500	2400
ALS-50	50 Kg	80	5	7	2600	1500	2400
ALS-100	100 Kg	160	5	11.5	5150	2700	3000
ALS-200	200 Kg	300	5	15	5150	2700	3700
ALS-300	300 Kg	400	5	20	5300	3700	3700
ALS-600	600 Kg	750	5	28	5800	4200	3700

STANDARD PARTS

Main Pump with Motor	Circulation Pump with Motor
Stock Tank	Transfer Pump with Motor
Two sets Hangers	Addition Tank
Sample Pot	Heat Exchanger
Control Panel with Programmer	Water level Indicator

OPTIONAL

Trolley with Carriers
 Stirrer with Motor
 120 °C Max. (for Polyester yarn)
 PLC (Fully Auto)

STANDARD MACHINERY FEATURES

Models	: 10-50-100-200-300-600
Operating Pressure	: 0.6 Bar
Testing Pressure	: 0.8 Bar
Operating Temperature	: 100 °C / 120 °C Max.
Operating Temperature	: 100 °C / 120 °C Max.
Heating Rate	: 3 °C per min (from 30 to 80 °C)
Level Controls	: Semi – Auto / Fully Auto (PLC)
Dyeing liquor ratio	: 1 : 8



ALS INDUSTRIES

Plot No. 13, E & E Industrial Estate, Suramangalam, SALEM - 636 005. TN. INDIA
 Phone : +91 427 2314721 Mobile : +91 94432 31032 e-mail : alsinds@gmail.com