



ISO 9001:2015 CERTIFIED CO.

Innovative
Next Generation
Technology

SCREW
Air Compressor



Never Stop your Air System

About Us

Air Care Equipments is India based company engaged in offering a comprehensive range of Air Compressors which have unmatched quality. Air Care Equipments is rated as one of the most reliable and reputed brands in High Pressure Air Compressors and Vacuum Pumps

We as a company, focus on growing and becoming successful by ensuring customer satisfaction. We have been successful in achieving this by constantly improving our product quality and new product developments. Using modern design and manufacturing techniques has been our strength. We have been, and shall always ensure that our products meet the national and international standards of quality and performance.

Our Mission

Our mission is to ensure customer delight with on-time supply of zero defect and quality products. The company today is a leading name in the category of Screw Compressors & Reciprocating Compressors particularly.

Our Vision

Innovation and continues improvement in all areas is our priority. We strive to deliver quality products while ensuring cost effectiveness. We aim to better our track seemed each day.

Our Success

Air Care Equipments is achieved the success today because of implementing latest technology in its Designing and production by following Model. Our company has been producing Receprocating Air Compressor, Air Receiver since 2005. Our manufacturing plant is located in Gurgaon, we manufacture a wide range of Industrial Air Compressors & Vacuum Pump. We are committed to provide products and services to our customer that meet the requirement and exceed their expectations.

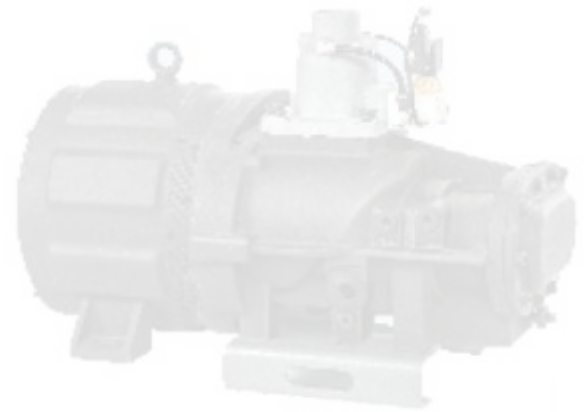



CONTROL PANEL

Control Panel / starter has been put in the cold zone which ensure long life operation. Switchgears are also made of Schneider/ABB/Siemens or standard quality.

SEAMLESS PIPELINE & COMPRESSION FITTING

General air compressor manufacturers used flexible tube in internal pipelines system. But air compressor can not be avoided operating conditions: oil, temperature and pressure, causing accelerated aging in hose. Air Care could be using compression fittings of seamless steel pipe fittings to prevent pipeline leaks, while reducing all the pressure loss. We use Seamless, long life pipelines instead of short-lived hose pipes, which eliminates oil leakages.



INTAKE VALVE WITH SAVING ENERGY

Intake valve with high-quality and high reliability effectively control the loading and unloading of machine, saving energy. Sol. valve service life is upto 2 million times more than the structure used to upgrade, no gap can be completely sealed, no need air cylinder pneumatic control, no seal diaphragm etc. wearing parts.

GEARLESS DIRECT DRIVE SCREW AIR COMPRESSOR

1:1 Direct drive is maintenance free coupling, which reduces number of components needed in gear drive, increasing reliability and durability through elimination of wear & transmission loss. Motor and the compressor are assembled to be embedded integral shaft direct connecting structure. Motor rotor is installed on the projecting shaft of the male rotor directly.





COMPRESSOR CONTROLLER

Advanced microprocessor based control system with features such as online pressure, temperature and current measurement, safety settings, online maintenance indications. It also has a unique fan control system which eliminates use of thermostats in the compressor.

HIGH CAPACITY DUAL AIR FILTER

Big size High efficient, dual filtering stage suction Air Filter for dusty environment of India with pre-filters.

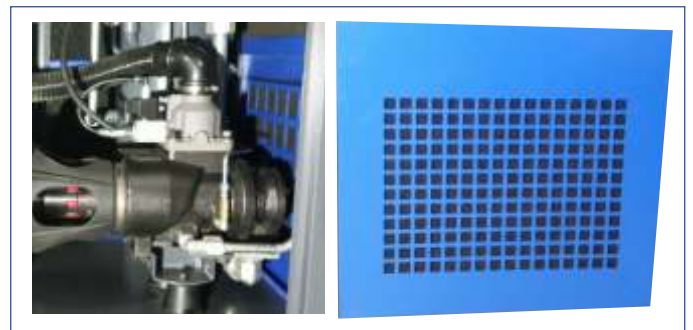

HIGH EFFICIENCY AFTERCOOLER

The enlarged high efficiency oil & air combination air-cooled aftercooler is specifically designed for South East Asia climate to assure all components work perfectly even under high ambient temperature & humidity summer season. All design data are referenced at 46°C ambient temperature.

OIL SEPARATOR WITH HIGH PRECISION

Use of large size oil and air separator, after three separate with high performance and ACE filter makes the oil content low 3 PPM, pressure loss is only 0.02 Mpa, to reduce oil mist discharge, greatly reduce the operating costs of downstream equipment.



TECHNICAL SPECIFICATIONS

DIRECT DRIVE MODELS (D-Series)

COMPRESSOR MODEL	MOTOR		FAD @ 8 kg/cm ²	FAD @ 10 kg/cm ²	FAD @ 13 kg/cm ²	SOUND LEVEL DB (±2)	DIMENSION LWH	WEIGHT KG.
	KW	HP	CFM	CFM	CFM		In MM	
ACD 7.5	5.5	7.5	26	24	NA	68	900x600x800	220
ACD 10	7.5	10	40	35	30	68	900x600x800	240
ACD 15	11	15	64	55	39	68	1100x730x980	360
ACD 20	15	20	85	72	60	70	1100x730x980	370
ACD 25	18.5	25	110	95	78	71	1200x880x1080	510
ACD 30	22	30	135	114	98	72	1200x880x1080	530
ACD 40	30	40	185	165	124	72	1460x980x1230	650
ACD 50	37	50	240	205	138	73	1460x980x1230	700
ACD 60	45	60	275	240	212	74	1460x980x1230	780
ACD 75	55	75	356	310	265	75	1750x1280x1590	1250
ACD 100	75	100	475	425	346	76	1750x1280x1590	1350
ACD 120	90	120	554	498	419	76	2450x1660x1700	1950

Main Structure

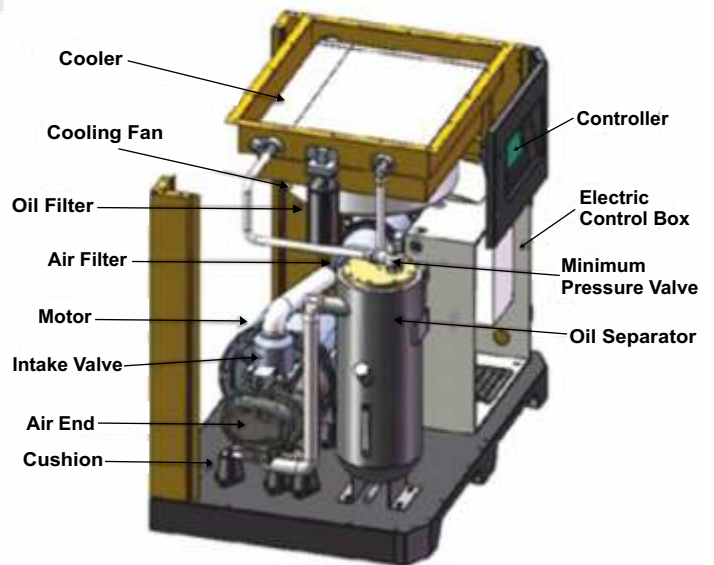

TYPICAL COMPRESSED AIR SUPPLY SYSTEM

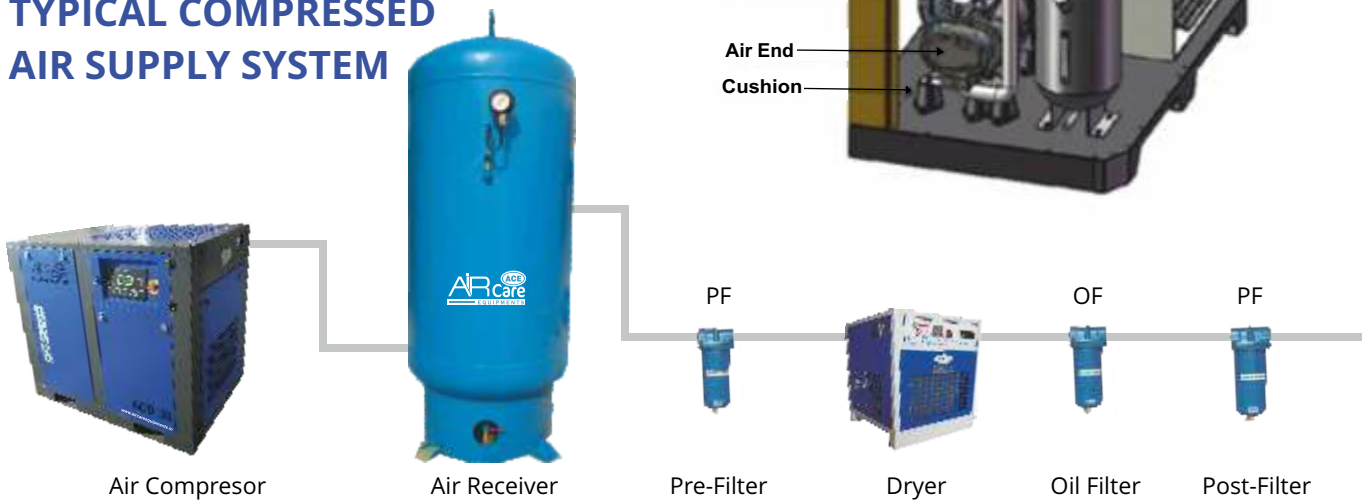

Air Compressor

Air Receiver

Pre-Filter

Dryer

Oil Filter

Post-Filter

VFD WITH PM MOTOR

A REVOLUTION IN ENERGY SAVING VFD (VARIABLE FREQUENCY DRIVE) WITH PM MOTOR

With the motive to reduce the Energy cost in our Air Compressors, we now introduce Energy saving Permanent Magnet Motors with our VFD models which decrease the Energy consumption substantially to save even more energy as well as money.

WHY PM MOTOR ?

- Interior Permanent Magnet (IPM) Motor **Efficiency upto 94.5%** which **Outperforms IE3 efficiency level.**
- On Average **20% Lower specific Energy Requirement** than the current VSD models.
- On top of energy savings. **Free Air Delivery (FAD) increase up to 12%** over the range.
- Compact small in size IPM motor has no bearings which means no wearing parts, no maintenance on motor side and no gear or belts, leading to a **Transmission Efficiency of 100%**



IPM Compressor

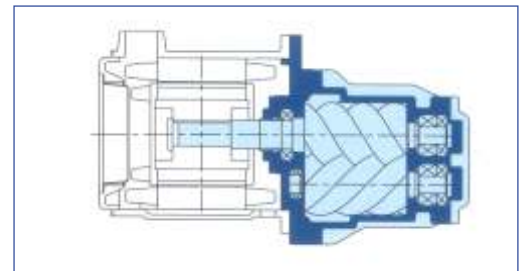

IPM One Shaft Structure

STANDARD QUALITY VFD



COMPRESSOR
CONTROLLER



FEATURES

SMOOTH START-UP

The VSD is soft starting, enabling controlled acceleration and deceleration which reduces stress on mechanical components and enhances system reliability. This results in increased life of the compressor.

SMART CONTROL

VSD keeps desired line pressure constant, adjusting automatically according to system air consumption by varying motor speed. The Compressor only consumes the energy needed to produce the compressed air required by the system. In fixed speed if compressor operates on no load, energy is wasted while no work is performed. VFD with PM motor saves up to 39% energy compared to conventional cycling.

A fixed speed compressor operates on a load-unload band of at least 10 PSI around the working pressure, whereas with VSD Compressor can be operated within a band of 2 PSI. For every 2 PSI reduction in operating pressure, there is 1% power saving.

VFD MODELS WITH PERMANENT MAGNET MOTOR (V-Series)

COMPRESSOR MODEL	MOTOR		FAD @ 8 kg/cm ²	FAD @ 10 kg/cm ²	FAD @ 13 kg/cm ²	SOUND LEVEL	DIMENSION LWH	WEIGHT
	KW	HP	CFM	CFM	CFM	DB (±2)	In MM	KG.
ACV 10	7.5	10	40	35	30	68	900x600x800	240
ACV 15	11	15	64	55	39	68	1100x730x980	360
ACV 20	15	20	85	72	60	70	1100x730x980	370
ACV 25	18.5	25	110	95	78	71	1200x880x1080	510
ACV 30	22	30	135	114	98	72	1200x880x1080	530
ACV 40	30	40	185	165	124	72	1460x980x1230	650
ACV 50	37	50	240	205	138	73	1460x980x1230	700
ACV 60	45	60	275	240	212	74	1460x980x1230	780
ACV 75	55	75	356	310	265	75	1750x1280x1590	1250
ACV 100	75	100	475	425	346	76	1750x1280x1590	1350
ACV 120	90	120	554	498	419	76	2450x1660x1700	1950

VFD MODELS WITH PERMANENT MAGNET MOTOR (Two Stage Series)

COMPRESSOR MODEL	MOTOR		FAD @ 8 kg/cm ²	SOUND LEVEL	COMPRESSOR RPM
	KW	HP	CFM	DB (±2)	
ACVT 40	30	40	215	72	1450
ACVT 50	37	50	258	73	1450
ACVT 60	45	60	352	74	1450
ACVT 75	55	75	405	75	1450
ACVT 100	75	100	565	76	1450



OUR OTHER PRODUCTS



**Air Compressor
10 HP**



**Air Compressor
5 HP**



**Refrigerated
Air Dryer**



**Heatless
Air Dryer**



AIR Care ACE
EQUIPMENTS

Air Receiver



**Oil Free
Compressor**

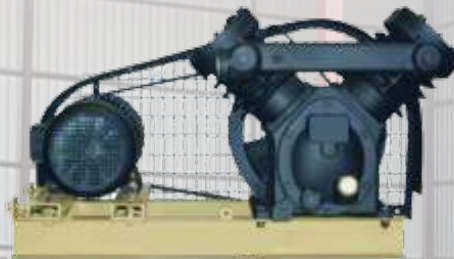

Vacuum Pump



Three Stage Filter



Moisture Separator

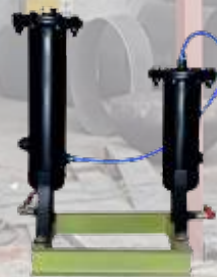

AIR PURIFIER



FRL



**AUTO DRAIN VALVE
220V**

*Technical Specifications are subject to change without prior notice due to constant up gradation of products

AIR CARE EQUIPMENTS

Sales Off. : Plot No.6, Gali No.8 Lane No.1 Kadipur Ind. Area, Pataudi Road Gurugram -122001 (Haryana)

Mfg. Plant : Khewat No.197/202, Khasra No.13/11 Village - Garauli Khurd, Gurugram-122001 (Haryana)

Mobile : 9871793228, 9599293541, 9811298770

E-mail : info@aircareequipments.in, sales@aircareequipments.in Website : www.aircareequipments.in



QR CODE SCAN