



JINALI TECHNO

JINALI TECHNO SALES AND SERVICE



FEDERATION OF INDIAN EXPORT ORGANISATIONS
Set up by Ministry of Commerce, Government of India
ISO 9001:2015 Certified



JINALI TECHNO SALES AND SERVICE. An ISO 9001:2015 certified company is one of the reputed supplier and exporter of Road & Building Construction Equipment. We have been providing our products and services on a global scale, meeting international quality standards since 2017.

- Asphalt Mixing Plant
- Concrete Mixing Plant
- Stone Crushing Plant
- Tower crane & Hoist
- Spare parts for Asphalt & Concrete Equipment

Experienced & Reliable Exporter, Since 2017

<https://jinalitechno.com/>

<https://www.jinalitechno.net/>



JINALI TECHNO SALES AND SERVICE

Company Profile



Our Works

Jinali Techno Sales and Service. is your premier destination for high-quality Road & Building Construction Equipment, meticulously crafted to meet global standards. As an ISO 9001:2015 certified company, we take pride in delivering top-notch products and services to clients worldwide.

Our Vision: Our vision is to be recognized globally as a leader in the export-import business, synonymous with quality, productivity, profitability, and customer satisfaction.

Our Mission: Driven by a passion for excellence, we are committed to consistently exceeding customer expectations.

Our mission is to provide unparalleled products and services, fostering growth and stability for our clients and partners worldwide.



Asphalt Drum Mix Plant

Asphalt Drum Mix Plant

Capacity : ADM 45, ADM 60, ADM 90, ADM 120 TPH

SALIENT FEATURES

- Portable or Stationery
- Low Dust Emissions
- Designed for the international Market
- Modern Drum Mix Technology
- Produces High Production Rate
- Easy Operation And Less Maintenance
- Easy to Operate
- Less Fuel Consumption
- Fully Automatic Computerized Control Panel Board
- Proper Drying And Homogeneous Mixing of Aggregate
- Accuracy in Quality Control



Asphalt Batch Mix Plant

Capacity : ABM 80, ABM 120, ABM 160, ABM 240, ABM 300 TPH

SALIENT FEATURES

- Bag Type Air pollution Control System Complete with Exhaust with Chimney
- Full Insulated dryer fitted with automatic silenced burner
- Bitumen storage and heating system with hot oil heat exchanger
- Hot elevator system
- Four/ five/ six deck vibratory screen
- Filler elevator for recovered dust from bag filters
- 4/5/6 batch feeder system fitted with independent variable drive electric motors
- Five hoppers for storage of hot aggregates



Concrete Batching Plant



Concrete Batching Plant

Capacity : CBM 30, CBM 45, CBM 60 m³

SALIENT FEATURES

- Inclined conveyor for feeding of aggregate into mixer
- Inline store of aggregates
- Aggregates weighing conveyor suspended on load cells
- Operation through fully automatic Electronic Control Panel
- Independent weighing system for cement, water and additive
- Manufacturing is done with advance Internationally recognised techniques
- Equipment with Pan/ Planetary/ Twin Shaft Mixer
- Global presence with prompt after-sales support



Transit Mixer

Capacity : 6, 7 and 9 m³

SALIENT FEATURES

- Zero segregation due to advanced imported technology
- Maintenance free fuel efficient engine
- Trouble free operation in extreme rough terrain
- Effective cooling due to advanced technology



Mobile Concrete Batching Plant

Capacity : 15, 18, 20, 25, 30 and 36 m³/hr

SALIENT FEATURES

- No foundation required
- Inbuilt cement feeding hopper on plant chassis
- Control Panel housed in a separate steel cabinet
- Cement screw conveyor & electric vibrators for sand and cement
- USB based removable storage is possible which eliminates the need of SCADA
- PLC & HMI touch screen for better accuracy and consistency
- Easy mobility



Automatic Concrete Block Machine



Block & Brick

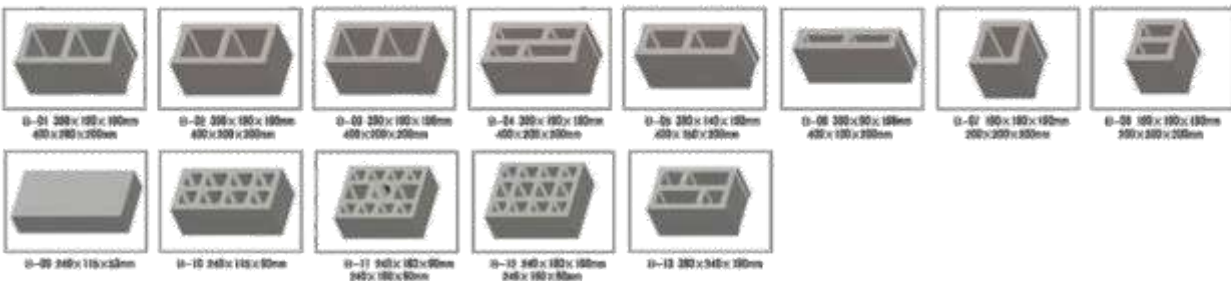

Interlocking Paver

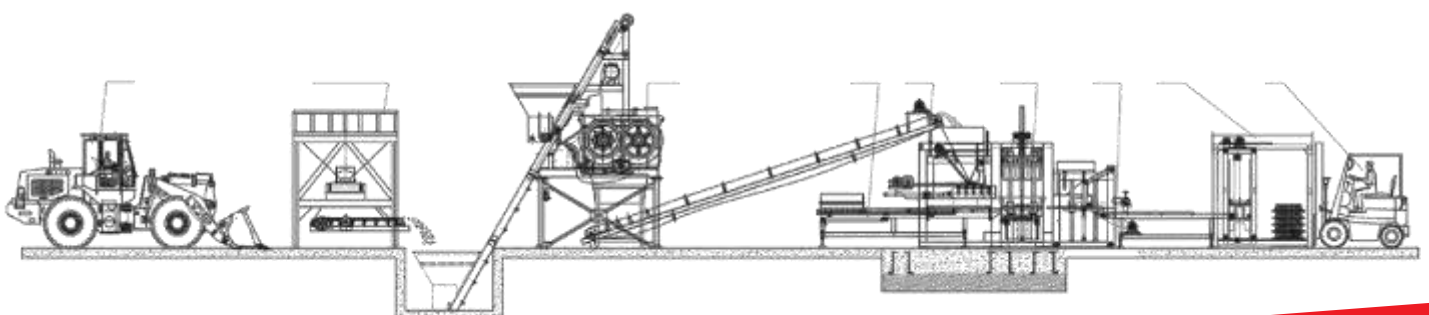
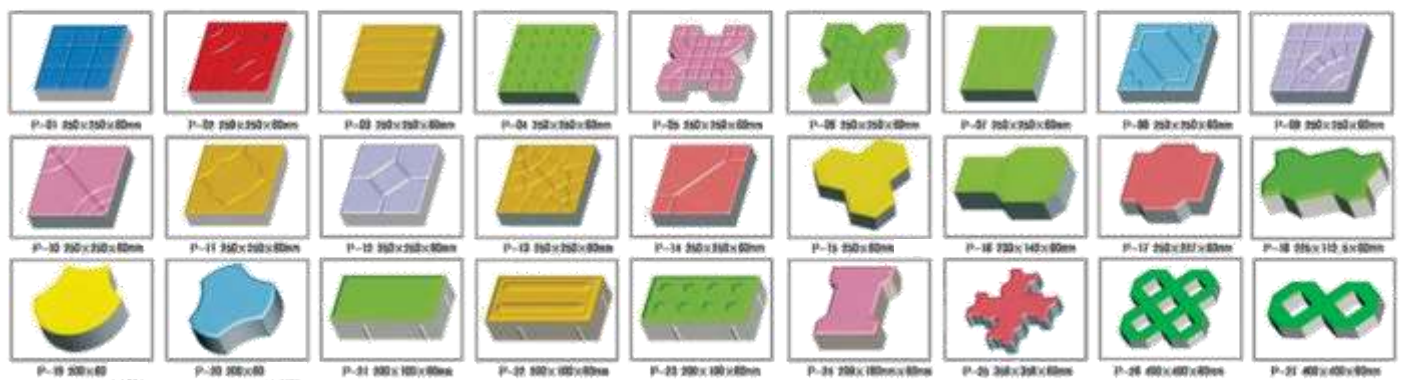

Stone Crushing Plant



Jaw-crusher



Cone Crusher



Impact hammer



Slip-form Curbing Machine

- Easy front & rear visibility
- High compaction ratio
- Low fuel consumption



Horizontal Cement / Fly Ash Silo System

Volume Capacity : 20, 45, 75 and 88 m³

SALIENT FEATURES

- Foundationless Silo
- Only PCC work of 200 mm is required
- Easy Transportation because of Skid Mounted design
- Equipped with Wam make silo accessories on same chassis
- Pollution - free cement handling system
- Arrangement for manual feeding of the silo



Hydraulic Sweeping Machine – Broomer

- Fastest mounting with tractor, due to three point linkage system
- Available with long life Polypropylene (PPN) Brush & Still Wire (MS Wire) Brush
- Easy to operate & maintain
- Sweep & collect @ 6km/hr or 13800 m²/hr
- Maintenance free sweeping machine



Tower Crane and Construction Hoist

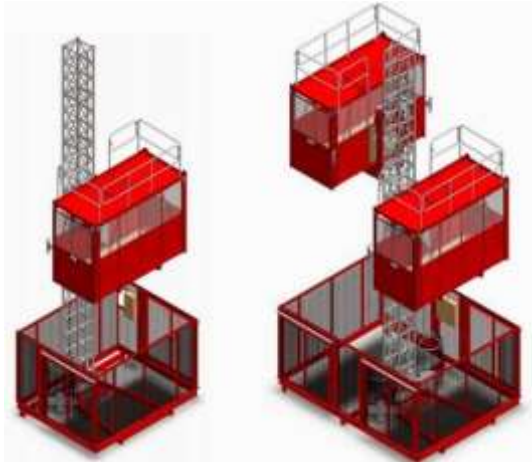

Spare Parts Asphalt & Concrete Equipment



Your Reliable Source for Road & Civil Construction Equipment Spare Parts, Jinali Techno have been exporting Spare Parts For Heavy Equipment, especially, Asphalt Batch Mix Plant, Concrete Batch Mix Plant Asphalt Drum Mix Plant, Asphalt paver Finisher, Road Roller, Concrete Pump and Tower Crane to more than 30 countries now. Today, Jinali Techno is one of the reputed exporter of Road Equipment Spare Parts in India. For Road Equipment & Road construction equipment parts, Jinali Techno will be the Ultimate and Best Solution.



Our presence worldwide



**FEDERATION OF INDIAN
EXPORT ORGANISATIONS**
Set up by Ministry of Commerce, Government of India
ISO 9001:2015 Certified



Corporate Office

347 A1 A2 Joyos Hub town Mehsana - 384002 ,North Gujarat (India)

Contact Person – Dharmendra Barot

Hand Phone - +91-79901 66421

E-Mail- dharmendra@jinalitechno.com

Website - <https://jinalitechno.com/>