

# Matrix

Water Treatment | Electricals | Oil Refining

# MATRIX INCORPORATION

Quality Management System ISO 9001 :2015, ANSI, CE, RoHS, FCC, Certified Company.

Manufacturing | Installations | Supply | Testing | Consulting | Engineering | Contracting

## EXPERTS IN CABLE TRAY & STRUT SUPPORT MANAGEMENT SYSTEM

EXPLORE >

### PRODUCT CATEGORY

≡ BEST PRODUCTS ≡

PRODUCTS

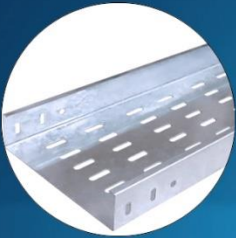

PERFORATED CABLE TRAY



CABLE TRUNKING



WIRE MESH CABLE TRAY



STEEL CABLE LADDER



FIBER OPTIC CABLE TRAY

## 10+ YEARS' EXPERIENCE

FOCUS ON CABLE MANAGEMENT  
SYSTEM OVER 10 YEARS

EXPLORE >



## Products Range



**GROUNDING**



**LIGHTNING**



**ELECTRICAL**



**SOLAR**

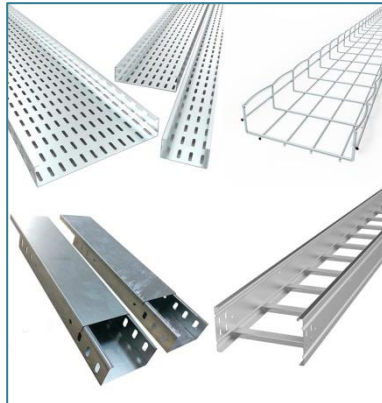

**CABLE TRAYS**



**EXOTHERMIC**

## Grounding Lightning Protection Products Factory

### Main Products

- Ground Rod
- Electrical Cable Wire
- Welding Mould/Material
- Bus Bar
- Cable Clamp
- Lightning Rod



**Earthing**

Content

- **Perforated Cable Tray**
- **Ladder Cable Tray**
- **Solid Bottom Cable Tray**
- **Heavy Angular Ladder Cable Tray**
- **Grating Assemblies**
- **Solar Panels Mounting Structures**
- **High Mast**
- **Cable Support Accessories & Fasteners**
- **Customized Cable Systems**

**We are a professional manufacturer specializing in cable & support systems for over 14 years.** Our company mainly specializes high quality electric systems, we providing to our clients the world class quality products across the globe.

### **MANUFACTURING SYSTEMS :**

Cable Management Systems (Cable Trays)

Supporting Systems

Earthing Systems

Lightning Protection Systems

Solar mounting Structure

Infrastructure Systems

Transmission & Powerlines System

We are one of the leading innovation developer, manufacturer, exporters global supplier of premium quality Electric Systems, Our products find applications across a diverse range of all types of domestic and industrials.

We have a strong team of highly experienced engineers and consultants to research, develop and customize new products.

Our in-house labs are equipped for the testing of samples on a daily basis before dispatch the material. Our stringent quality checking process includes checks at all stages – Raw material, finished goods, processing and final packings.



- **Perforated Cable Tray**
- **Ladder Cable Tray**
- **Solid Bottom Cable Tray**
- **Heavy Angular Ladder Cable Tray**
- **Grating Assemblies**
- **Solar Panels Mounting Structures**
- **High Mast**
- **Cable Support Accessories & Fasteners**
- **Customized Cable Systems**



## **THOUSANDS OF SUCCESSFUL CASES**



## **VERTICALLY INTEGRATED PROJECT DEVELOPMENT**

[EXPLORE >](#)

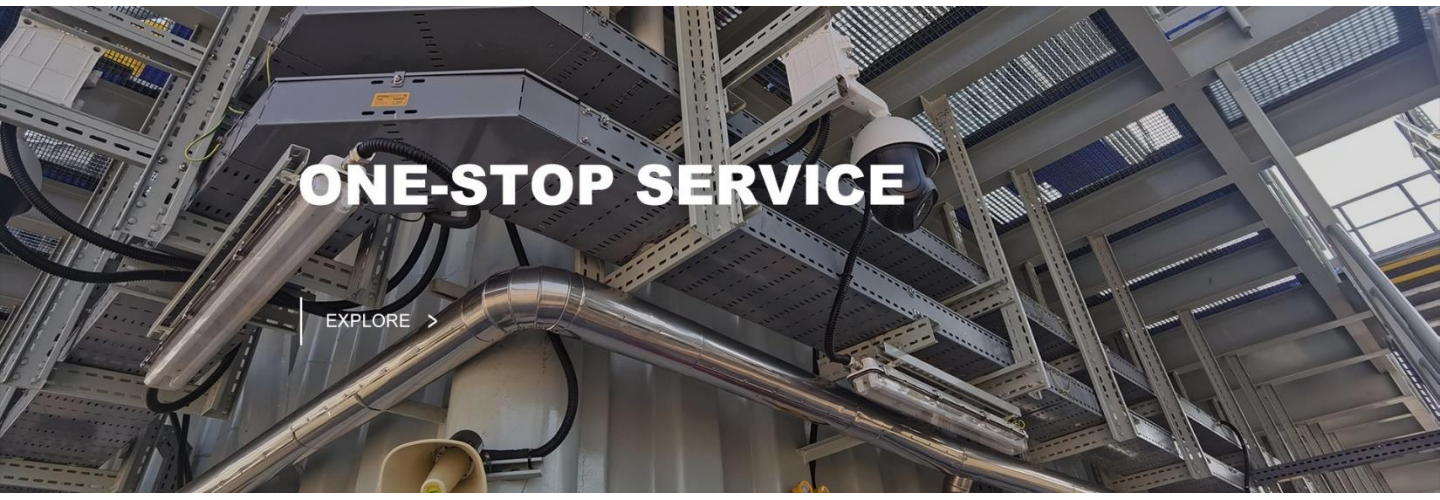

## **ONE-STOP SERVICE**

[EXPLORE >](#)



# PERFORATED CABLE TRAYS

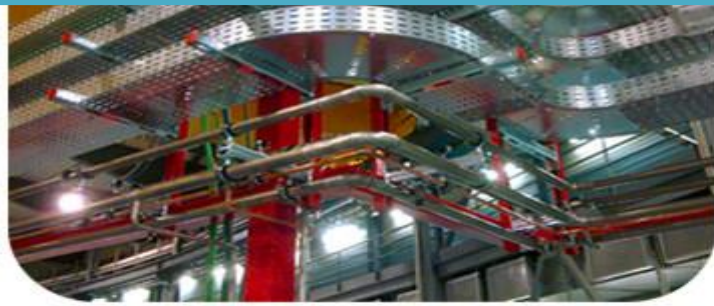

## PERFORATED CABLE TRAY

- (PRE-GALVANIZED / MILL GALVANIZED)
- HOT DIP GALVANIZED
- POWDER COATED
- ALUMINUM
- STAINLESS STEEL 304/316
- ENAMEL SPRAY COLOR COATED COATED
- MILD STEEL
- FRP

PERFORATED CABLE TRAYS

# PERFORATED CABLE TRAYS

**Matrix**

EARTHING | LIGHTNING | CABLE TRAYS | POWER GRID



**HOT DIP GALVANIZED PERFORATED TYPE CABLE TRAYS**

**Matrix**

EARTHING | LIGHTNING | CABLE TRAYS | POWER GRID



**PRE-GALVANIZED PERFORATED TYPE CABLE TRAYS**

**Matrix**

EARTHING | LIGHTNING | CABLE TRAYS | POWER GRID



**STAINLESS STEEL PERFORATED TYPE CABLE TRAYS**

**Matrix**



**Perforate Cable Trays Powder Coated**

**Matrix**

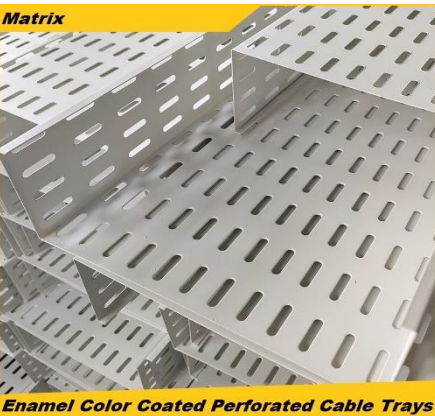

**Enamel Color Coated Perforated Cable Trays**

**Matrix**



**Mild Steel Perforated Cable Tray**



**VERTICAL BEND INSIDE**



**VERTICLE BEND OUTSIDE**



**VERTICLE BEND**

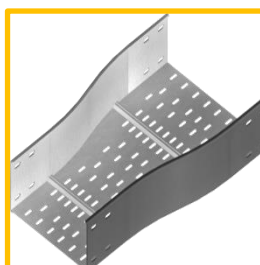

**REDUCER**

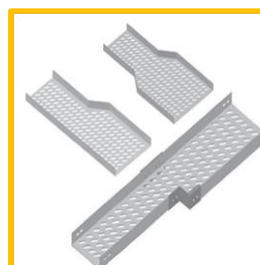

**ONE SIDE REDUCER**

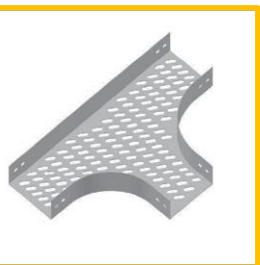

**TEE HORIZONTAL**

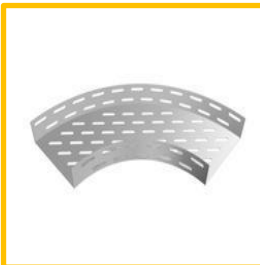

**HORIZONTAL BEND**



**CROSS**

## DIMENSIONS

|               |   |
|---------------|---|
| Width (W)     | 50mm to 1200mm  |
| Height (H)    | 25mm to 175mm   |
| Thickness (T) | 1.2mm, 1.6mm, 2mm, 2.5mm & 3mm                              |
| Length (L)    | 2000 / 3000 / 2500mm / 3300mm & 2444 mm (for Aluminium)     |
| MOC           | MS Steel, Stainless Steel, Aluminium, Non-Metallic, Coating |

| FINISH                                    | SPECIFICATION                    | RECOMMENDED USE  |
|---|----------------------------------|------------------|
| Painted                                   | As per Specifications            | Indoor           |
| Powder Coated                             | As per Specifications            | Indoor           |
| Pre Galvanized                            | ASTM A653SS                      | Indoor           |
| Hot Dip Galvanized                        | As per IS 4759, 2629, 2633, 2623 | Indoor / Outdoor |
| Electrogalvanized Zinc                    | ASTM B633                        |                  |
| Chromium Zinc                             | ASTM F-1136-88                   |                  |
| Hot Dip Galvanized Zinc After Fabrication | ASTM A123                        |                  |

## MATERIAL SPECIFICATIONS

|                 |   |
|-----------------|---|
| MILD STEEL      | IS 1079<br>ASTM A1011 (14 Gauge Plain Steel)<br>ASTM A1008<br>ASTM A653 (Pre-Galvanized)<br>ASTM A510 |
| Aluminum        | 6063-T6 (Side rails, Rungs and Splice Plates)<br>5052-H32 (Trough Bottoms, Covers and Accessories)    |
| Stainless Steel | AISI Type 304 or AISI Type 316/316L ASTM A240   |

## STANDARDS

|                  |                    |
|------------------|--------------------|
| Indian Standards | 4759 / 2629 / 2623 |
| ASTM             | 123A               |
| IEC              | 61537 : 2006       |

## CERTIFICATIONS

|                 |
|-----------------|
| ISO 9001 : 2015 |
| CE              |
| ROHS            |
| FCC             |



# LADDER CABLE TRAYS

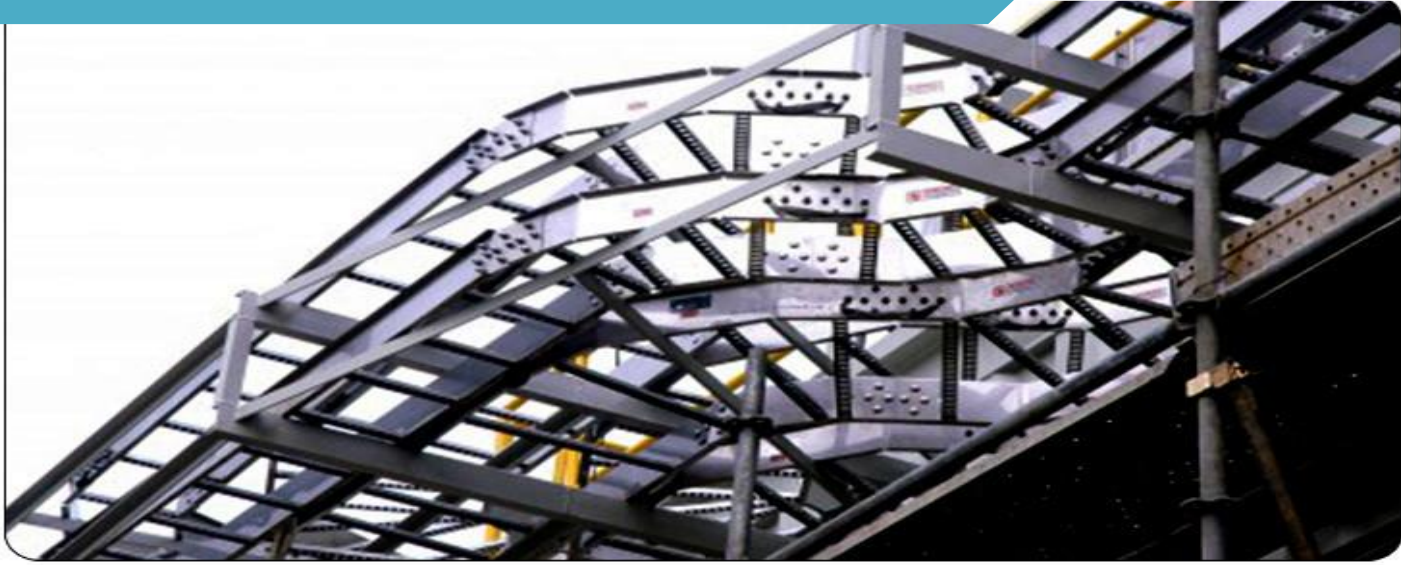

## LADDER CABLE TRAY

- PRE-GALVANIZED / MILL GALVANIZED
- HOT DIP GALVANIZED
- POWDER COATED
- ALUMINUM
- STAINLESS STEEL 304/316
- COLOR COATED
- MILD STEEL
- FRP



# LADDER TYPE CABLE TRAYS

**Matrix**

EARTHING | LIGHTNING | CABLE TRAYS | POWER GRID



Hot Dip Galvanized Ladder Type Cable Trays

**Matrix**

EARTHING | LIGHTNING | CABLE TRAYS | POWER GRID



GI Ladder Type Cable Trays

**Matrix**



Stainless Steel Ladder Cable Trays

**Matrix**



Aluminum Ladder Cable Trays

**Matrix**

EARTHING | LIGHTNING | CABLE TRAYS | POWER GRID



Ladder Cable Trays Powder Coated



**VERTICAL BEND INSIDE**



**VERTICAL BEND OUTSIDE**



**TEE HORIZONTAL**



**CROSS**



**HORIZONTAL BEND**



**ONE SIDE REDUCER**



**EQUAL REDUCER**

# WIRE MESH CABLE TRAYS

Wire mesh cable tray

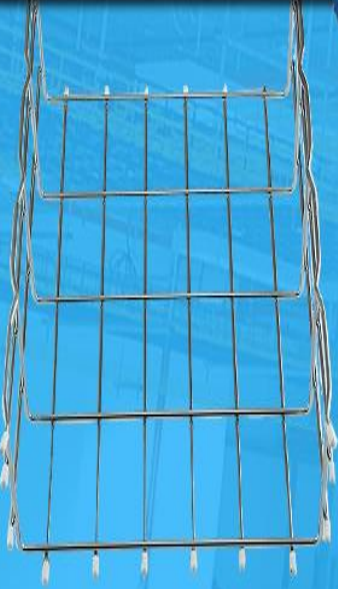

## WIRE MESH CABLE TRAY

- (PRE-GALVANIZED / MILL GALVANIZED)
- HOT DIP GALVANIZED
- POWDER COATED
- STAINLESS STEEL 304/316
- ENAMEL SPRAY COLOR COATED COATED
- YELLOW CHROME COATING

WIRE MESH CABLE TRAYS



# TYPES OF WIRE MESH CABLE TRAYS

**Matrix**

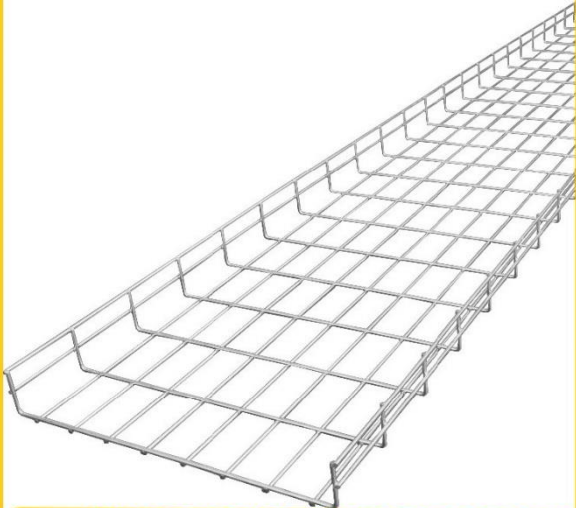

**Hot Dip GI Wire Mesh Cable Tray**

**Matrix**

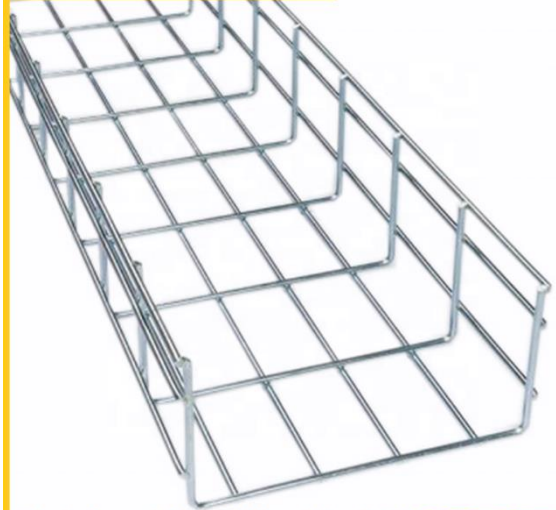

**Stainless Steel Wire Mesh Cable Trays**

**Matrix**



**Mild Steel Wire Mesh Cable Tray**

**Matrix**

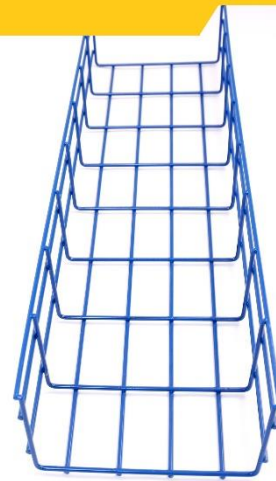

**Powder Coated Wire Mesh Cable Tray**

# ACCESSORIES & SUPPORT SYSTEMS

## WIRE MESH CABLE TRAYS



Wall Termination Clamp

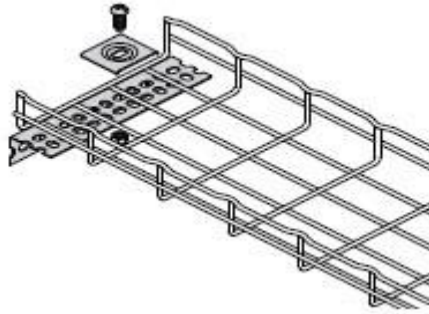

C Brackets

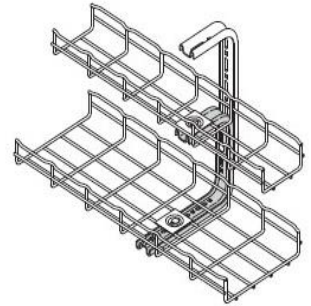
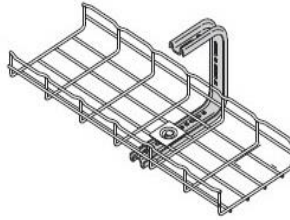
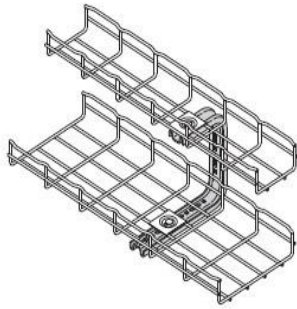

Strut & Support Channel

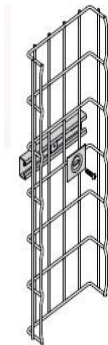

Vertically Mounted

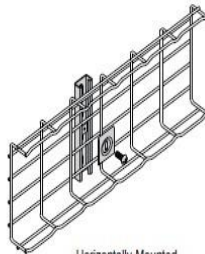

Horizontally Mounted



Z Brackets

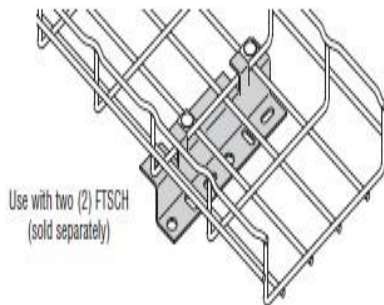

Use with two (2) FTSCH  
(sold separately)



# ACCESSORIES & SUPPORT SYSTEMS

## WIRE MESH CABLE TRAYS

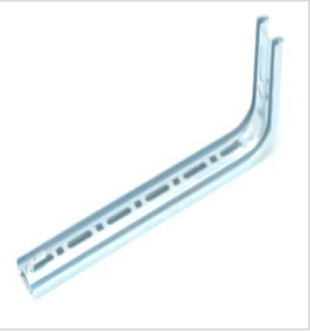

L Brackets

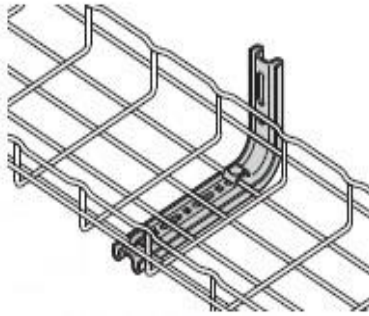

Splice Bar Kit

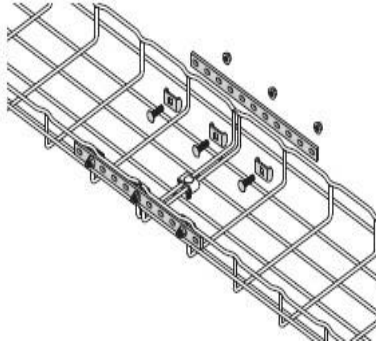

Connecting Fasteners

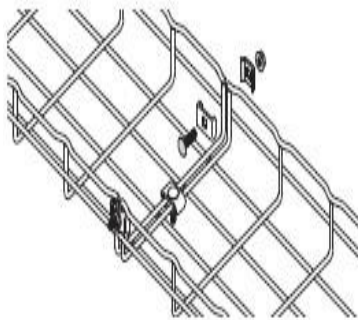

Threaded Rods

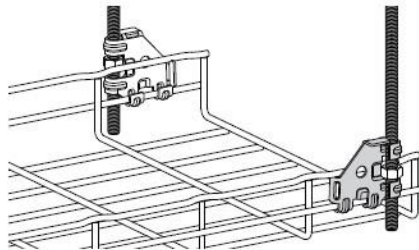

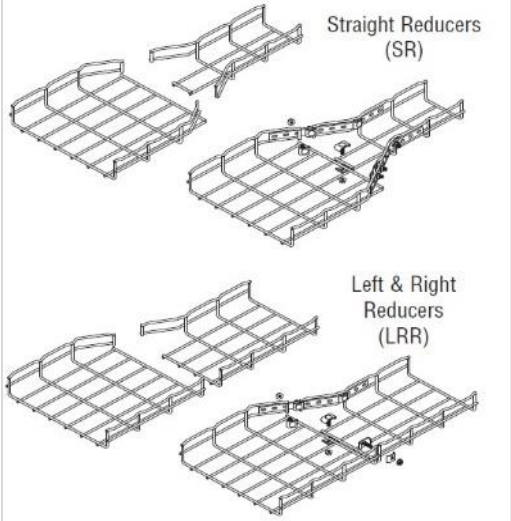

Reducers

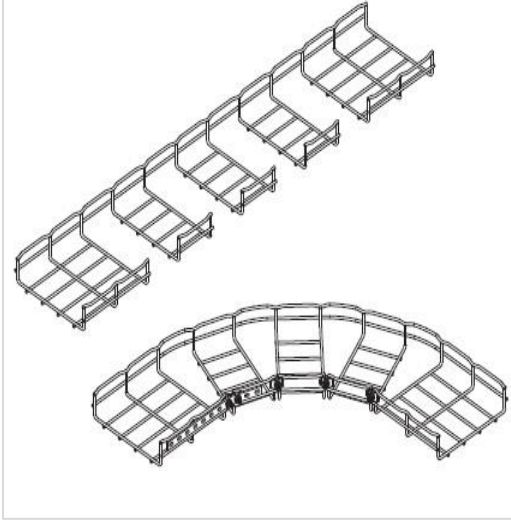

Horizontal Bends

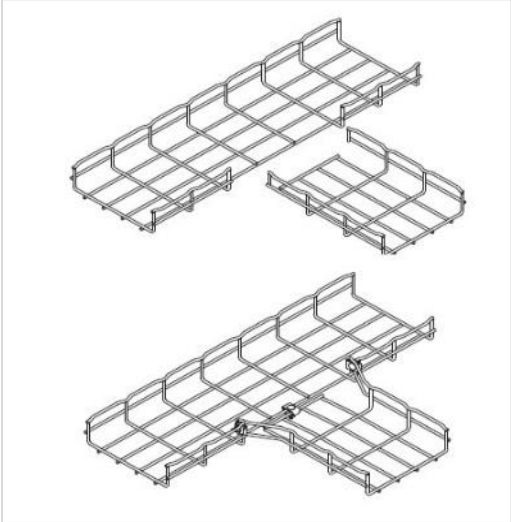

Horizontal Tees

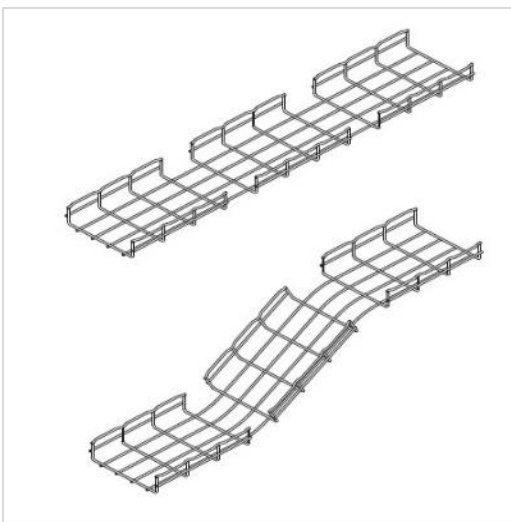

Vertical Outsider/Insiders



# WIRE MESH TYPE CABLE TRAYS

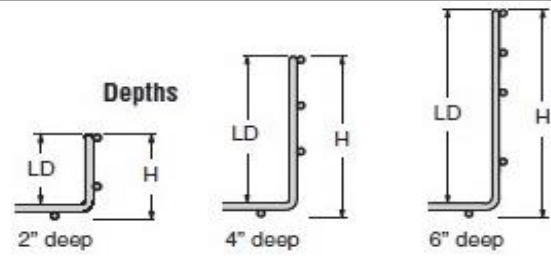
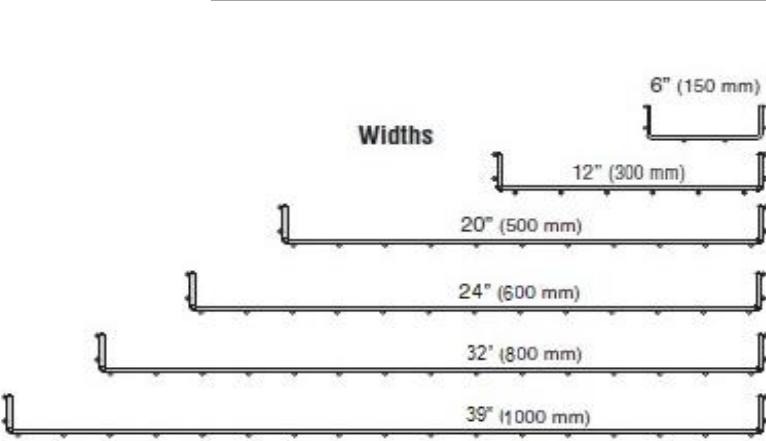

| WIDTH | DEEP (WALL)     | WIRE (DIA)                 | LENGTH                     | METALS  |
|-------|-----------------|----------------------------|----------------------------|---|
| 50    | 50              | 4mm                        | 2000mm<br>2500mm<br>3000mm | <ul style="list-style-type: none"> <li>• Mild Steel</li> <li>• Stainless Steel</li> <li>• Hot Dip Galvanized</li> <li>• Yellow Chrome Coated</li> </ul> |
| 100   | 50              | 4mm                        | 2000mm<br>2500mm<br>3000mm |   |
| 150   | 50              | 4mm                        | 2000mm<br>2500mm<br>3000mm |   |
| 200   | 50<br>80<br>100 | 4mm<br>6mm<br>8mm          | 2000mm<br>2500mm<br>3000mm |   |
| 300   | 50<br>80<br>100 | 4mm<br>6mm<br>8mm          | 2000mm<br>2500mm<br>3000mm |   |
| 400   | 50<br>80<br>100 | 4mm<br>6mm<br>8mm          | 2000mm<br>2500mm<br>3000mm |   |
| 450   | 50<br>80<br>100 | 4mm<br>6mm<br>8mm          | 2000mm<br>2500mm<br>3000mm |   |
| 500   | 50<br>80<br>100 | 4mm<br>6mm<br>8mm          | 2000mm<br>2500mm<br>3000mm |   |
| 600   | 50<br>80<br>100 | 4mm<br>6mm<br>8mm          | 2000mm<br>2500mm<br>3000mm |   |
| 800   | 50<br>80<br>100 | 6mm<br>8mm<br>10mm         | 2000mm<br>2500mm<br>3000mm |   |
| 1000  | 50<br>80<br>100 | 6mm<br>8mm<br>10mm<br>12mm | 2000mm<br>2500mm<br>3000mm |   |

## DIMENSIONS

|                                |   |
|--------------------------------|---|
| <b>Width (W)</b>               | 50mm to 1200mm  |
| <b>Side Channel Height (H)</b> | 50mm to 150mm   |
| <b>Run Width</b>               | 30mm to 50mm  |
| <b>Run Height</b>              | 10mm to 20mm  |
| <b>Run C to C</b>              | 250mm to 300mm  |
| <b>Thickness (T)</b>           | 1.6mm, 2mm, 2.5mm & 3mm   |
| <b>Length (L)</b>              | 2000 / 3000 / 2500mm & 2444 mm (for Aluminium)                          |
| <b>MOC</b>                     | MS Steel, Stainless Steel, Galvanized, Yellow Chrome and powder Coating |

| FINISH                                    | SPECIFICATION                    | RECOMMENDED USE  |
|---|----------------------------------|------------------|
| Painted                                   | As per Specifications            | Indoor           |
| Powder Coated                             | As per Specifications            | Indoor           |
| Pre Galvanized                            | ASTM A653SS                      | Indoor           |
| Hot Dip Galvanized                        | As per IS 4759, 2629, 2633, 2623 | Indoor / Outdoor |
| Electrogalvanized Zinc                    | ASTM B633                        |                  |
| Chromium Zinc                             | ASTM F-1136-88                   |                  |
| Hot Dip Galvanized Zinc After Fabrication | ASTM A123                        |                  |

## MATERIAL SPECIFICATIONS

|                 |   |
|-----------------|---|
| MILD STEEL      | IS 1079<br>ASTM A1011 (14 Gauge Plain Steel)<br>ASTM A1008<br>ASTM A653 (Pre-Galvanized)<br>ASTM A510 |
| Aluminum        | 6063-T6 (Side rails, Rungs and Splice Plates)<br>5052-H32 (Trough Bottoms, Covers and Accessories)    |
| Stainless Steel | AISI Type 304 or AISI Type 316/316L ASTM A240   |

## STANDARDS

|                  |                    |
|------------------|--------------------|
| Indian Standards | 4759 / 2629 / 2623 |
| ASTM             | 123A               |
| IEC              | 61537 : 2006       |

## CERTIFICATIONS

|                 |
|-----------------|
| ISO 9001 : 2015 |
| CE              |
| ROHS            |
| FCC             |



# RACEWAYS

Cable tray and trunking



## RACEWAYS CABLE TRAY

- PRE-GALVANIZED / MILL GALVANIZED
- HOT DIP GALVANIZED
- POWDER COATED
- ALUMINUM
- STAINLESS STEEL 304/316
- COLOR COATED
- MILD STEEL
- FRP

RACEWAYS CABLE TRAYS

**Matrix**



**GI Cable Raceways**

**Matrix**



**Hot Dip GI Cable Raceways**

**Matrix**



**Stainless Steel Cable Raceways**

**Matrix**



**Aluminum Cable Raceways**

**Matrix**



**Powder Coated Cable Raceways**

## DIMENSIONS

|                                |   |
|--------------------------------|---|
| <b>Width (W)</b>               | 50mm to 1200mm                                |
| <b>Side Channel Height (H)</b> | 50mm to 200mm                                 |
| <b>Wire Thickness (T)</b>      | 1.2 / 1.6 / 2.0 / 2.5 / 3.0 mm                |
| <b>Length (L)</b>              | 2000 / 2500 / 3000 mm                         |
| <b>MOC</b>                     | MS Steel, Stainless Steel, Aluminum , Coating |

| FINISH                                    | SPECIFICATION                    | RECOMMENDED USE  |
|---|----------------------------------|------------------|
| Painted                                   | As per Specifications            | Indoor           |
| Powder Coated                             | As per Specifications            | Indoor           |
| Pre Galvanized                            | ASTM A653SS                      | Indoor           |
| Hot Dip Galvanized                        | As per IS 4759, 2629, 2633, 2623 | Indoor / Outdoor |
| Electrogalvanized Zinc                    | ASTM B633                        |                  |
| Chromium Zinc                             | ASTM F-1136-88                   |                  |
| Hot Dip Galvanized Zinc After Fabrication | ASTM A123                        |                  |

## MATERIAL SPECIFICATIONS

|                 |   |
|-----------------|---|
| MILD STEEL      | IS 1079<br>ASTM A1011 (14 Gauge Plain Steel)<br>ASTM A1008<br>ASTM A653 (Pre-Galvanized)<br>ASTM A510 |
| Aluminum        | 6063-T6 (Side rails, Rungs and Splice Plates)<br>5052-H32 (Trough Bottoms, Covers and Accessories)    |
| Stainless Steel | AISI Type 304 or AISI Type 316/316L ASTM A240   |

## STANDARDS

|                  |                    |
|------------------|--------------------|
| Indian Standards | 4759 / 2629 / 2623 |
| ASTM             | 123A               |
| IEC              | 61537 : 2006       |

## CERTIFICATIONS

|                 |
|-----------------|
| ISO 9001 : 2015 |
| CE              |
| ROHS            |
| FCC             |



# HEAVY DUTY CABLE TRAYS



# ANGULAR LADDER TYPE CABLE TRAYS



Angular Ladder type heavy duty cable support system .

Heavy duty Trays available in below material.

- Pre-coated
- Hot Dip Galvanized Steel
- Stainless Steel
- Powder Coated
- Enamel Spray coated.

These cable trays specially for heavy weight cables.



## PRODUCT APPLICATIONS

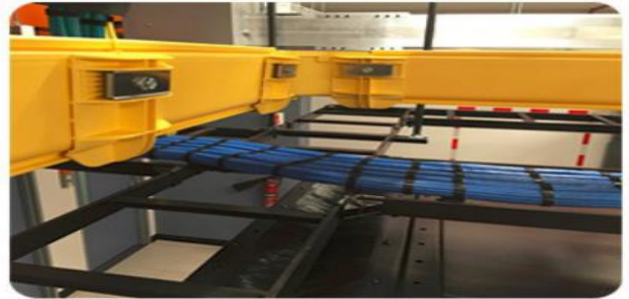



# SOLAR PANELS MOUNTING STRUCTURES

**MATRIX PROVIDE WIDE RANGE OF SOLAR PANELS & MOUNTING SYSTEMS:**

- **HOT DIP GALVANIZED**
- **PRE-GALVANIZED**
- **ALUMINUM**
- **STAINLESS STEEL**

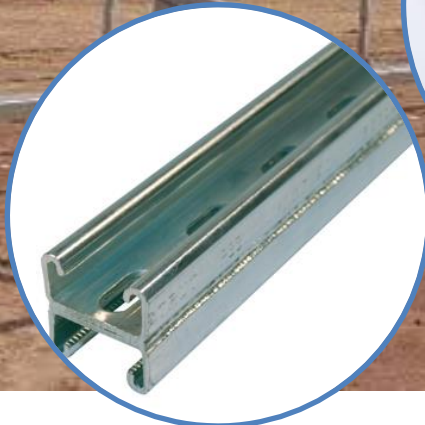
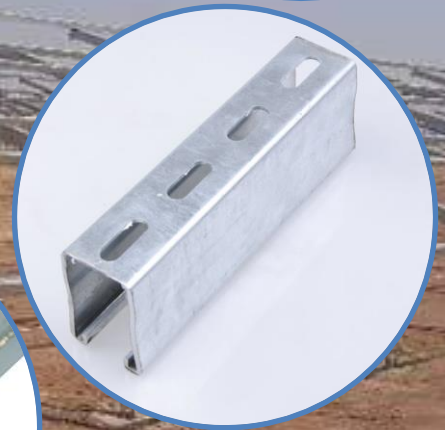

Customized cable support system produce from hot dip heavy galvanised steel channel & angular bars .

These cable system supporting system mounting on RCC foundation for provide strong basement to manage heavy weight and control cable runways



We provide customized Cable management support system specially for heavy armored cables indoor & out-door areas.



# CABLE SYSTEM ACCESSORIES

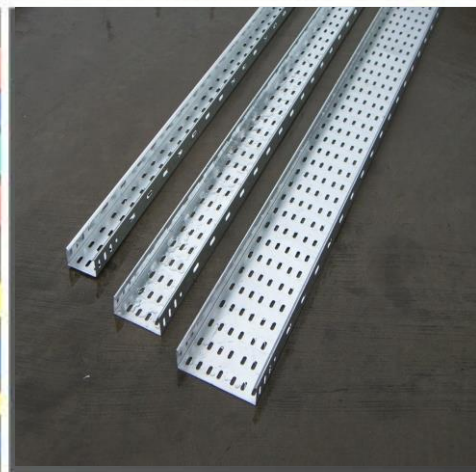



## Finishing



B: Black/Plain



PG: Pre-galvanized



EG:Electrc-galvanized



HDG: Hot dip galvanized



Y:Yellow Zinc



C: Copper Plated



EP:Brown Epoxy



GR: Green Painted



BP:Black Epoxy



SS304/SS316

# Matrix

Water Treatment | Electricals | Oil Refining

## MATRIX INCORPORATION

Quality Management System ISO 9001 :2015, ANSI, CE, RoHS, FCC, Certified Company.

Manufacturing | Installations | Supply | Testing | Consulting | Engineering | Contracting

**ADMIN OFFICE :** # U-4 Ground Floor  
Mittal Chambers, M.G Road,  
Secunderabad - 500003 T.S., INDIA.

**REGD. ADDRESS :** # 20-4-529/5 & 6,  
Khilwat, Hyderabad - 500002,  
T.S., INDIA.

Contact : +91 7780599423 / +91 9052729776

Tel No. : +91-40-42607464

Fax No. : +91-40-42607464

Email : [matrixhpc@gmail.com](mailto:matrixhpc@gmail.com)

[matrixhpccomponents@gmail.com](mailto:matrixhpccomponents@gmail.com)

Web : [www.matrixincorporation.com](http://www.matrixincorporation.com)

GSTIN No. : 36DCCPM5274B1ZR, PAN No. : DCCPM5274B, MSME : TS02A0047175

# Matrix

Electricals | Water Treatment | Oil Refining



## MANUFACTURER

A wide range of products that can be customized according to customer requirement



## EXPORTING

Exporting 52 countries, gained positive feedbacks and praises. Owning professional technical and sales team



## QUALITY

Strict inspection of product quality before shipment and track the life of the product



## SERVICE

Any small problem happening in our products will be solved at the most prompt time

## INDUSTRIES WE SERVE



POWER INDUSTRY



PETROCHEMICAL INDUSTRY



RAIL INDUSTRY



PHARMACEUTICALS INDUSTRY



SOLAR INDUSTRY



WIND INDUSTRY



OIL AND GAS



WATER INDUSTRY



MINING &



FOOD & BEVERAGE



CONSTRUCTION



MANUFACTURING

## Matrix incorporation Projects

## Contact us :

Office : U4, Mittal Chambers, MG Road, Pan Bazar, Secunderabad - 500 003, T.S. India.

Warehouse : L1 & L2, Hilton Icon, Beside Marriott Country Yard Hotel, Secunderabad - 500 003, T.S. India.

Mobile : +91 7780599423, 9985195336, Tel. No.: +91 40 4260 7464, Fax : +9140 4260 7464,

Email : matrixhpc@gmail.com matrixhpccomponents@gmail.com, Website : matrixincorporation.com

GROUNDING

LIGHTNING

ELECTRICAL

SOLAR

EXOTHERMIC

CABLE TRAYS

COATINGS