

UAN: DL11A0007259

**OM ENGINEERING WORKS**  
Fabrication of All Crane Duty Gear Boxes



®

[www.omengineeringwork.in](http://www.omengineeringwork.in)

# REDUCTION GEARS

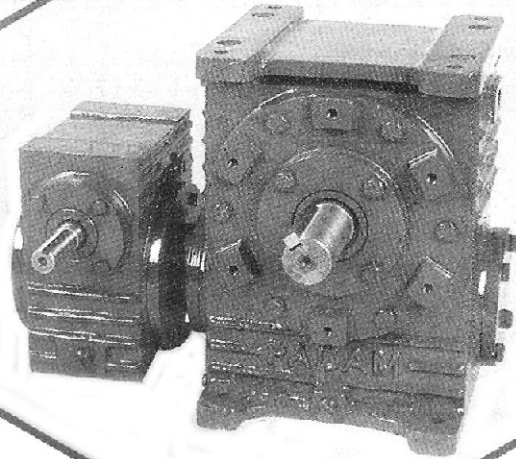
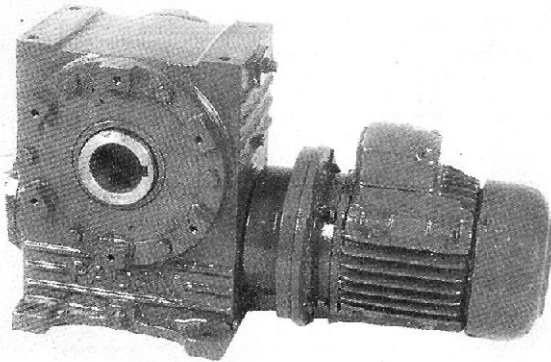
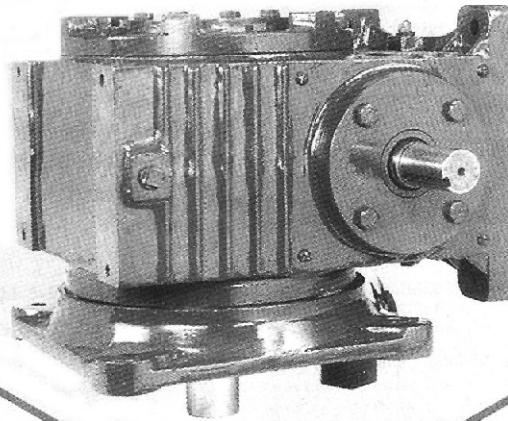

**Serving Gear Industry for over 30 years**

# COMPANY PROFILE



with its unmatched strengths in technical expertise and commitment to customers, has pioneered radical changes in the Gear Box Industry in India. With superior R & D and quality-control, Padam has been manufacturing Gear Boxes which have redefined excellence.



Its comprehensive range of Gear Boxes include horizontal, vertical and universal models. Not satisfied with this, Padam has even upgraded its operations to manufacture Gear Boxes for special application and also as per customer specification.

But this improvement of technology is not accompanied by an elevation in prices. In fact, **INDIAN** policy of high production reduces the fixed cost per unit to a level which enables Padam to price its products at a lower rate, thereby ensuring a higher value for money.

It is  determination to excel and its adherence to international standards of quality control ensures that all the Gears and worms are perfectly hardened and grounded, thus ensuring a trouble-free longer life of the Gear Box.

It also realises the importance of after sales - service to its customers. For this,  has a ready inventory of spare parts and a team of qualified engineers with a commitment to provide superior after sales service to its valued customers.

# UNIQUE FEATURES OF PADAM REDUCTION GEARS

**OEW** Single and Double Type Reduction Gears are manufactured in our most sophisticated factory; fully equipped with imported machines catering to the latest technology. Each  Reduction Gear is manufactured by technical hands. Every  Reduction Gear goes through a rigorous quality test before being despatched. We have the unique distinction of getting back any gear due to manufacturing defect.

**1. The Housing :** Made from the best grade of cast iron duly seasoned to stand tropical conditions. It is of neat mechanical appearance and strong construction having a large capacity oil reservoir. All faces and bores are accurately machined on imported machines to ensure the perfect alignment. The case is made completely oil tight and dust proof.

**2. Worm :** The worm is of special Alloy Steel duly hardened grounded on imported cnc thread grinding machine. Worms are generated on special purpose imported worm milling machines.

**3. Worm Wheel :** Made from selected grade of phosphorus bronze, cast under controlled conditions to give best combination of strength and bearing properties. The worm wheels are hobbled on precision hobbing machines with high accuracy grinded hobs. Each and every wheel is checked to match with the master worms to ensure complete interchangeability.

**4. Wheel Shaft:** The wheel shaft is of carbon steel to carry the torsional stresses and bending loads.

**5. Bearing :** The worms and worm wheels are supported on ball or roller antifriction bearings to take the radial as well as thrust load. SKF Bearings are used depending upon availability or otherwise standard make are used.

**6. Lubrication :** Oil bath lubrication is provided to lubricate both the shaft bearings and the gear sets for extra smooth running, to effectively circulate the oil to the high and low speed bearings depending on the working position of the unit.

**7. Cooling :** Air cooling is effected by means of standard plastic or metal fans which direct a continuous flow of air over the ribbed surface of the case. Suitable fans and ribs are provided for cooling .

**8. Test and Inspection :** Proper tests are carried out during and after manufacturing. A full speed test is carried out to verify smooth and noiseless operation.

# TYPE - NS/H HORIZONTAL

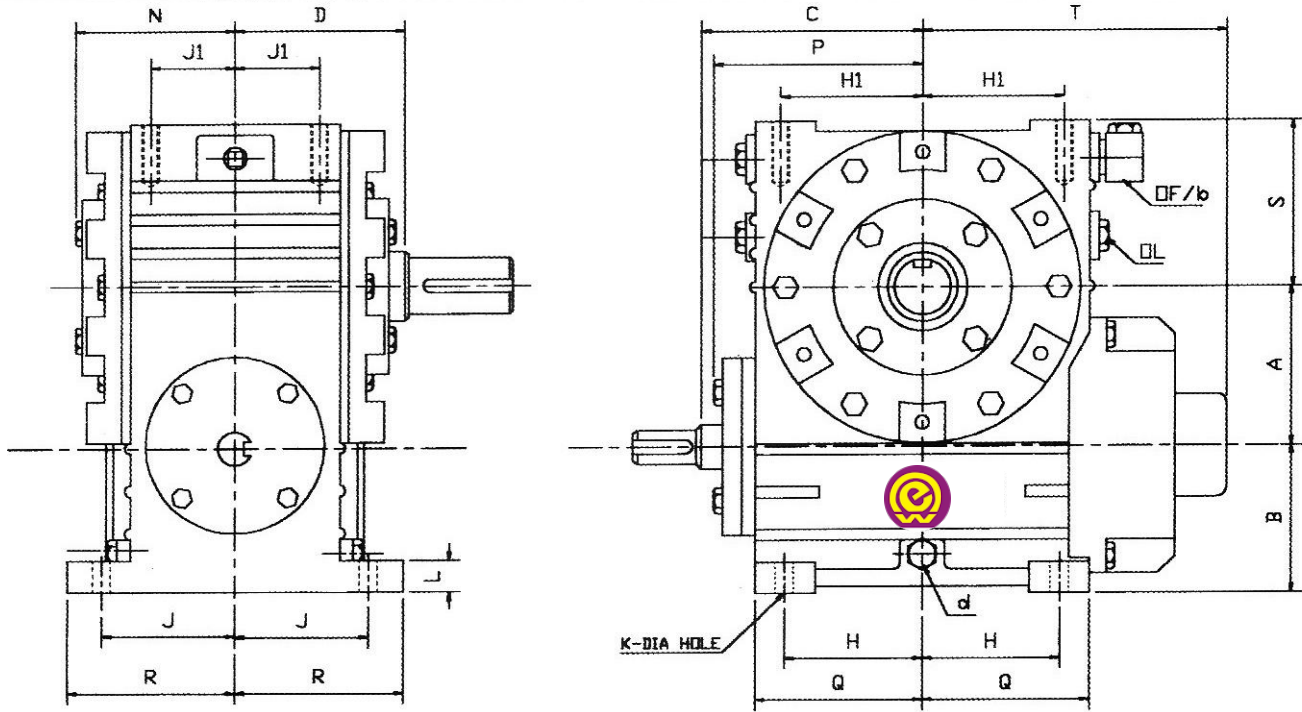

## SHAFT HANDLING

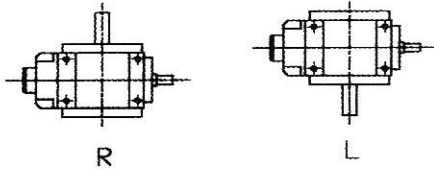

## SHAFT DETAIL

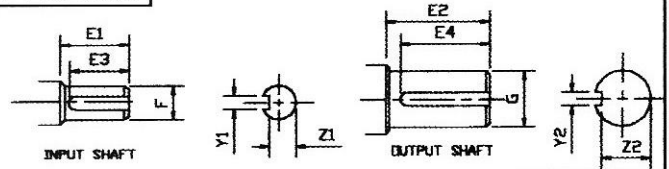

Size	A	B	C	D	H	HI	J	JI	K	L	N	P	Q	R	S	T
2"	2"	57	94	70	54	54	58	35	11	14	68	90	70	75	80	145
2.5"	2.5"	63	108	84	64	72	67	40	11	14	78	104	85	80	92	162
3"	3"	86	128	95	80	82	77	48	11	18	90	120	98	90	105	190
3.5"	3.5"	86	140	108	91	91	84	54	14	20	98	130	110	100	115	200
4"	4"	108	164	128	108	115	102	65	18	22	120	158	136	120	130	240
5"	5"	114	190	148	124	131	111	75	18	26	130	185	158	136	150	272
6"	6"	127	205	165	133	140	121	85	22	30	140	195	170	150	185	295

## SHAFT DIMENSIONS

Size	E1	E2	E3	E4	F	G	Y1	Y2	Z1	Z2
2"	44	54	40	50	18	23	5	6	15	20
2.5"	50	56	45	52	23	27	6	8	20	23
3"	56	68	52	63	27	33	6	10	24	29
3.5"	56	78	52	73	27	38	6	10	24	34
4"	65	90	60	85	32	45	8	12	28	40
5"	70	102	65	98	38	55	10	16	34	49
6"	74	110	70	105	38	60	10	16	34	54

# TYPE - NS/O OVERDRIVEN

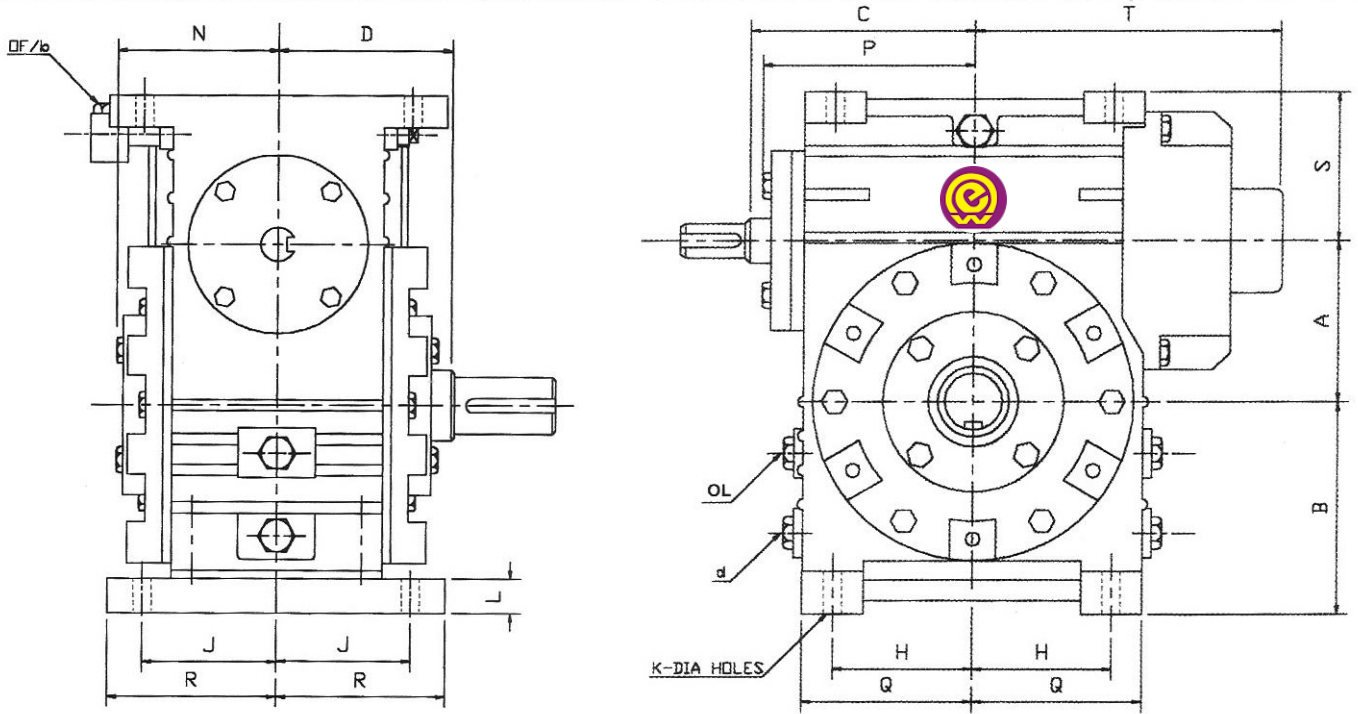

## SHAFT HANDLING

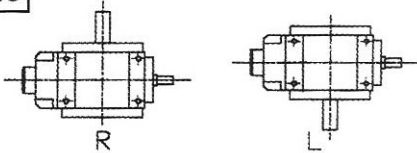

## SHAFT DETAIL

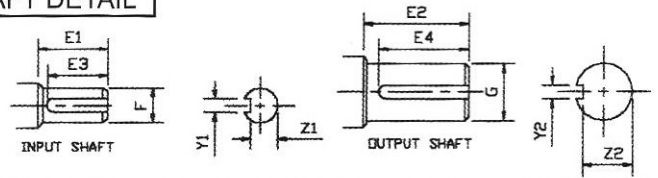

Size	A	B	C	D	H	J	K	L	N	P	Q	R	S	T
2"	2"	100	94	70	54	58	11	14	68	90	70	75	57	145
2.5"	2.5"	112	108	84	64	67	11	14	78	104	85	80	63	162
3"	3"	125	128	95	80	77	11	18	90	120	98	90	85	190
3.5"	3.5"	140	140	108	91	84	14	20	98	130	110	100	85	200
4"	4"	160	164	128	108	102	18	22	120	158	136	120	108	240
5"	5"	180	190	148	124	111	18	26	130	185	158	136	114	272
6"	6"	215	205	165	133	121	22	30	140	195	170	150	127	295

## SHAFT DIMENSIONS

Size	E1	E2	E3	E4	F	G	Y1	Y2	Z1	Z2
2"	44	54	40	50	18	23	5	6	15	20
2.5"	50	56	45	52	23	27	6	8	20	23
3"	56	68	52	63	27	33	6	10	24	29
3.5"	56	78	52	73	27	38	6	10	24	34
4"	65	90	60	85	32	45	8	12	28	40
5"	70	102	65	98	38	55	10	16	34	49
6"	74	110	70	105	38	60	10	16	34	54

# TYPE - NS/V VERTICAL

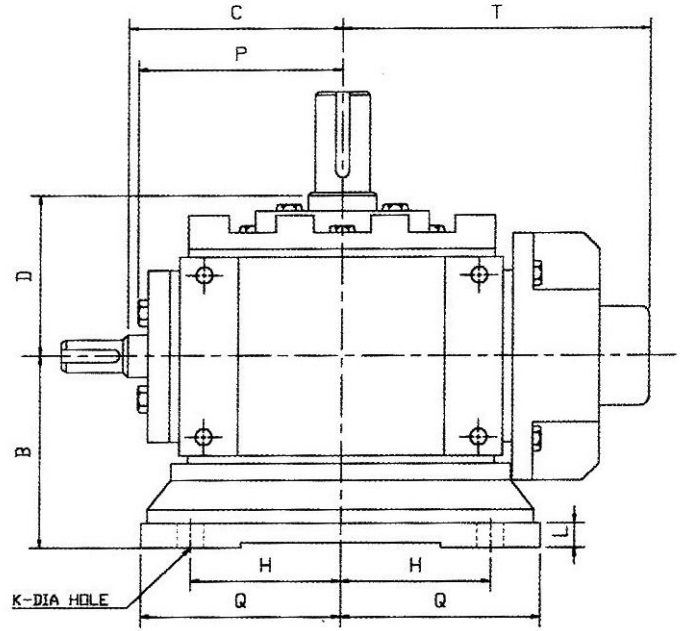
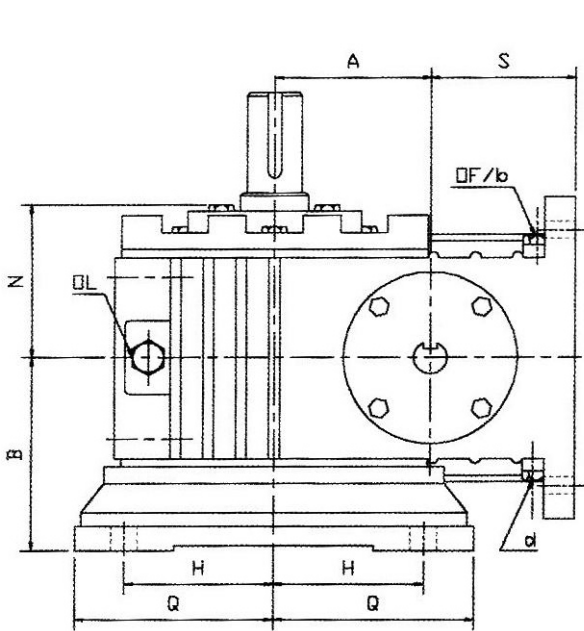

## SHAFT HANDLING

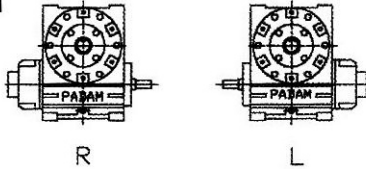

## SHAFT DETAIL

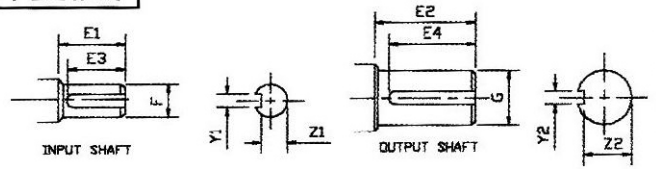

Size	A	B	C	D	H	K	L	N	P	Q	S	T
2"	2"	90	94	70	64	11	14	68	90	80	57	145
2.5"	2.5"	98	108	84	75	11	14	78	104	90	63	162
3"	3"	115	128	95	100	11	18	90	120	118	86	190
3.5"	3.5"	120	140	108	105	14	20	98	130	124	86	200
4"	4"	144	164	128	114	18	22	120	158	140	108	240
5"	5"	172	190	148	140	18	26	130	185	160	114	272
6"	6"	172	205	165	152	22	30	140	195	178	127	295

## SHAFT DIMENSIONS

Size	E1	E2	E3	E4	F	G	Y1	Y2	Z1	Z2
2"	44	54	40	50	18	23	5	6	15	20
2.5"	50	56	45	52	23	27	6	8	20	23
3"	56	68	52	63	27	33	6	10	24	29
3.5"	56	78	52	73	27	38	6	10	24	34
4"	65	90	60	85	32	45	8	12	28	40
5"	70	102	65	98	38	55	10	16	34	49
6"	74	110	70	105	38	60	10	16	34	54

# TYPE - NS/D DOUBLE REDUCTION

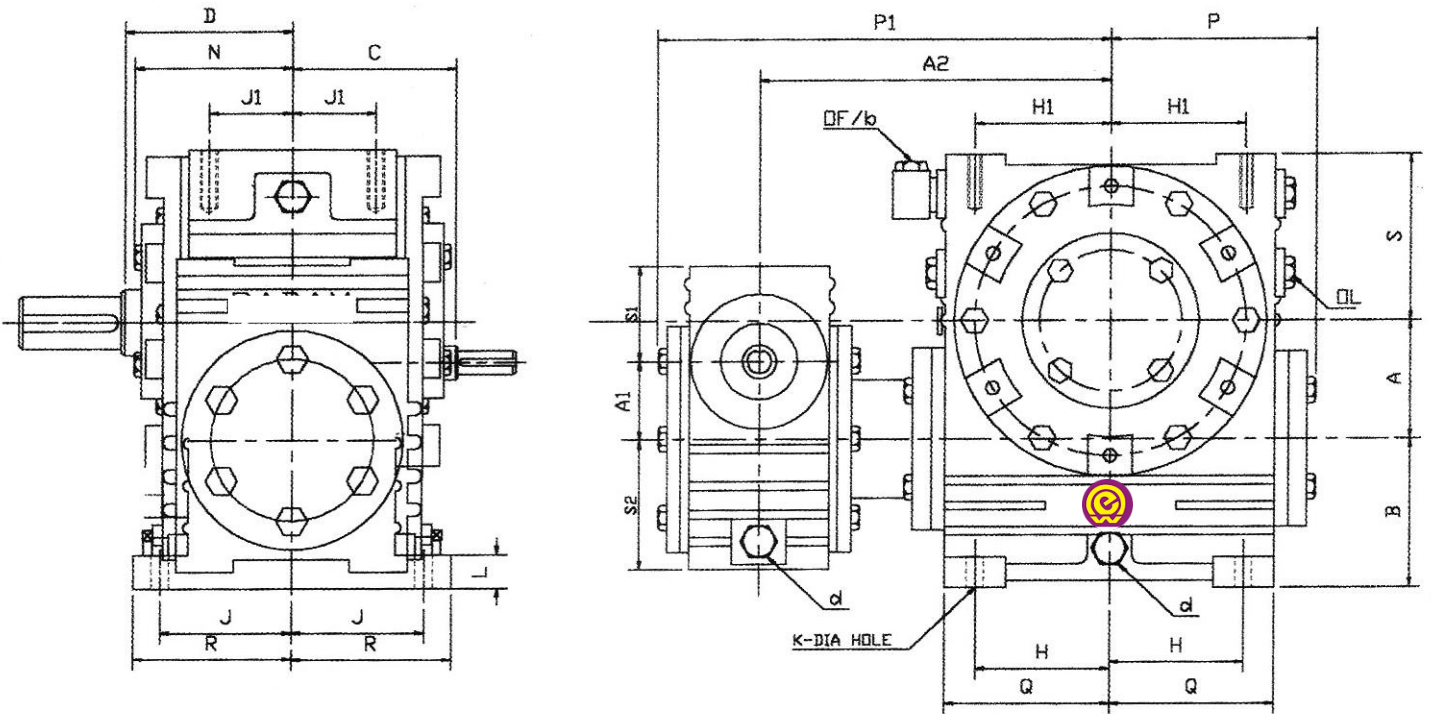

## SHAFT HANDLING

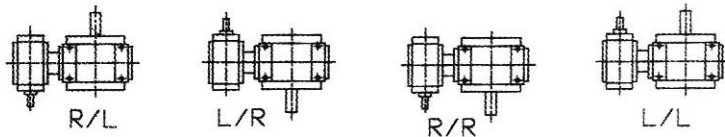

## SHAFT DETAIL

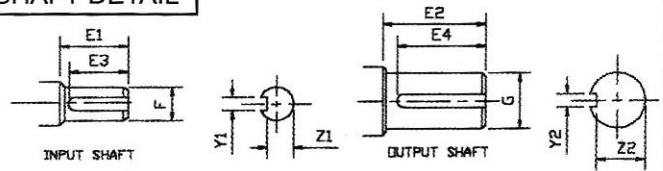

Size	A	A1	A2	B	C	D	H	H1	J	J1	K	L	N	P	P1	Q	R	S	S1	S2
2"	2"	2"	165	57	94	70	54	54	58	35	11	14	68	90	225	70	75	80	57	80
2.5"	2.5"	2"	180	63	94	84	64	72	67	40	11	14	78	104	240	85	80	92	57	80
3"	3"	2"	195	86	94	95	80	82	77	48	11	18	90	120	255	98	90	105	57	80
3.5"	3.5"	2"	205	86	94	108	91	91	84	54	14	20	98	130	265	110	100	115	57	80
4"	4"	2.5"	245	108	108	128	108	115	102	65	18	22	120	158	315	136	120	130	63	92
5"	5"	3"	285	114	128	148	124	131	111	75	18	26	130	185	365	158	136	150	86	105
6"	6"	4"	325	127	164	165	133	140	121	85	22	30	140	195	435	170	150	185	108	130

## SHAFT DIMENSIONS

Size	E1	E2	E3	E4	F	G	Y1	Y2	Z1	Z2
2"	44	54	40	50	18	23	5	6	15	20
2.5"	44	56	40	52	18	27	5	8	15	23
3"	44	68	40	63	18	33	5	10	15	29
3.5"	44	78	40	73	18	38	5	10	15	34
4"	50	90	45	85	23	45	6	12	20	40
5"	56	102	52	98	27	55	6	16	24	49
6"	65	110	60	105	32	60	8	16	28	54

# TYPE - NS/DV DOUBLE VERTICAL

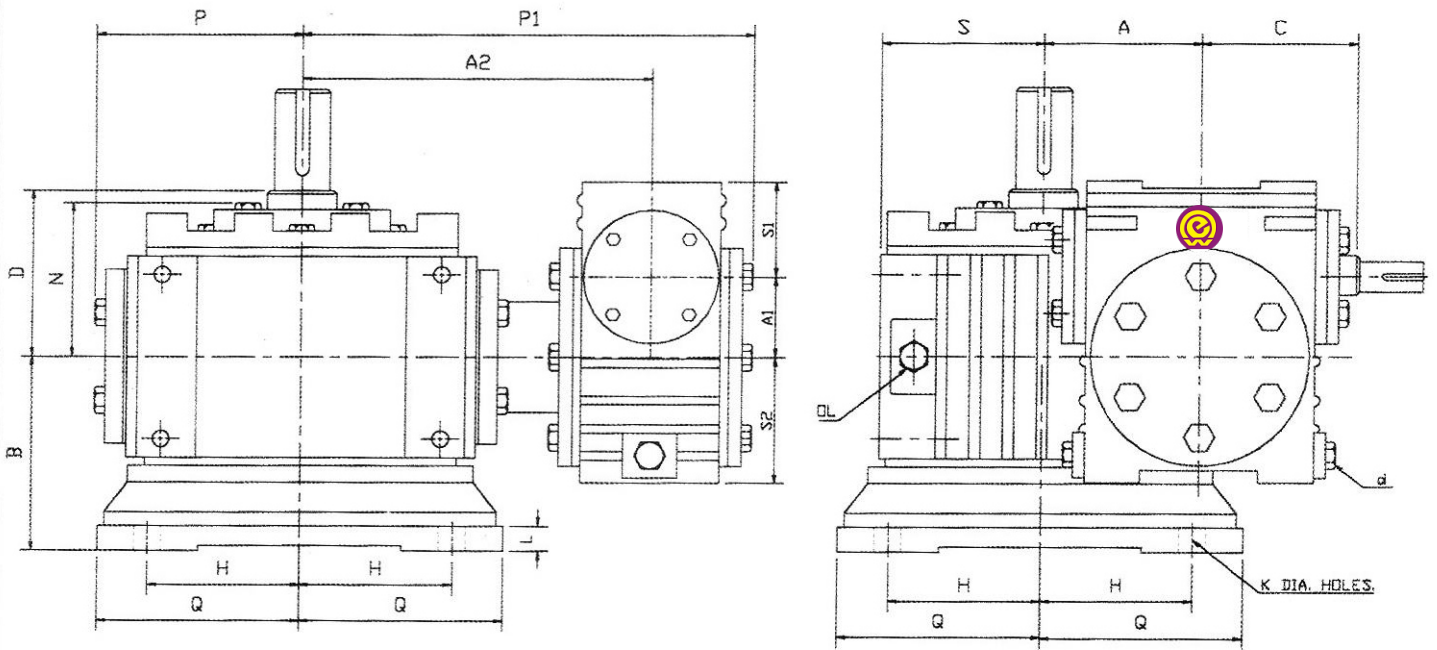

## SHAFT HANDLING

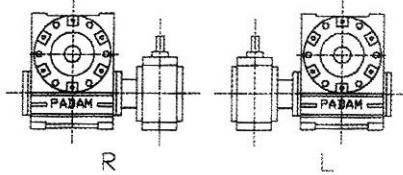

## SHAFT DETAIL

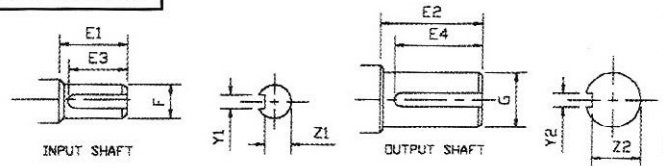

Size	A	A1	A2	B	C	D	H	K	L	N	P	P1	Q	S	S1	S2
2"	2"	2"	165	90	94	70	64	11	14	68	90	225	80	80	57	80
2.5"	2.5"	2"	180	98	94	84	75	11	14	78	104	240	90	92	57	80
3"	3"	2"	195	115	94	95	100	11	18	90	120	255	118	105	57	80
3.5"	3.5"	2"	205	120	94	108	105	14	20	98	130	265	124	115	57	80
4"	4"	2.5"	245	144	108	128	114	18	22	120	158	315	140	130	63	92
5"	5"	3"	285	172	128	148	140	18	26	130	185	365	160	150	86	105
6"	6"	4"	325	172	164	165	152	22	30	140	195	435	178	185	108	130

## SHAFT DIMENSIONS

Size	E1	E2	E3	E4	F	G	Y1	Y2	Z1	Z2
2"	44	54	40	50	18	23	5	6	15	20
2.5"	44	56	40	52	18	27	5	8	15	23
3"	44	68	40	63	18	33	5	10	15	29
3.5"	44	78	40	73	18	38	5	10	15	34
4"	50	90	45	85	23	45	6	12	20	40
5"	56	102	52	98	27	55	6	16	24	49
6"	65	110	60	105	32	60	8	16	28	54

# TYPE - NS/H MOTORISED HORIZONTAL

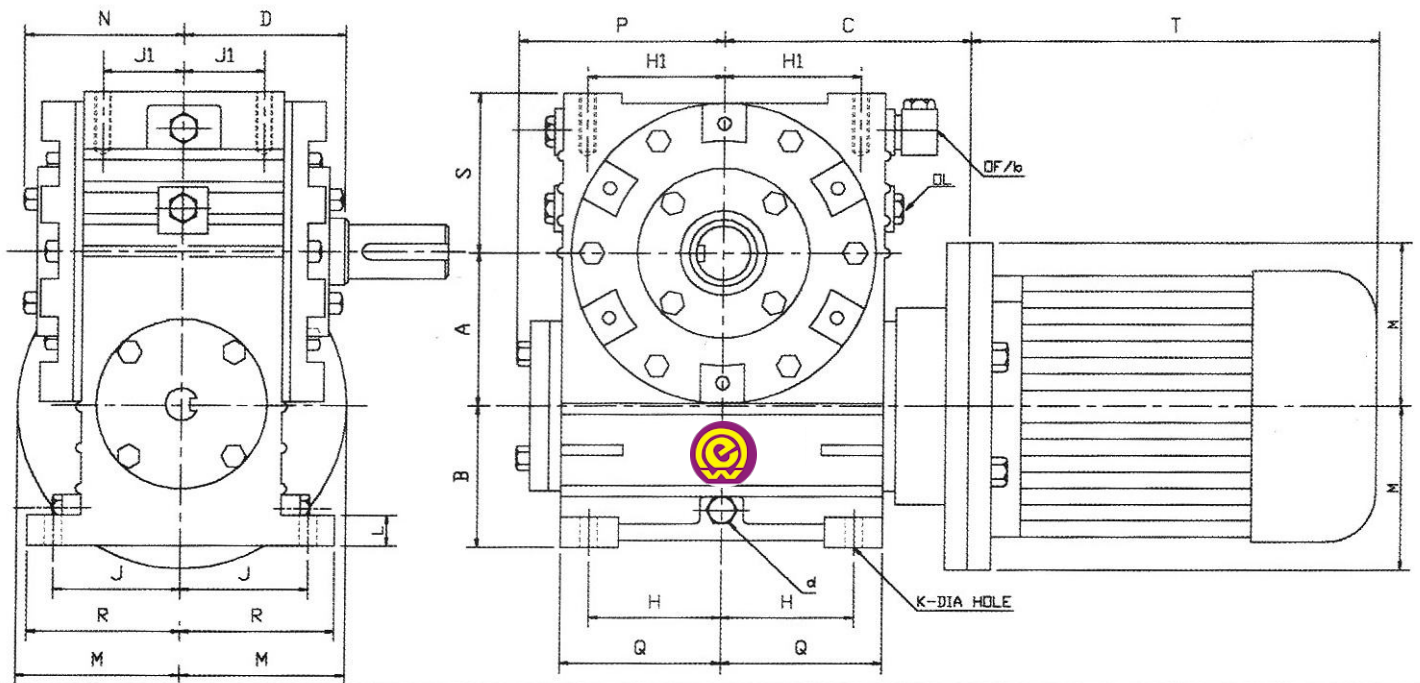

SHAFT HANDLING

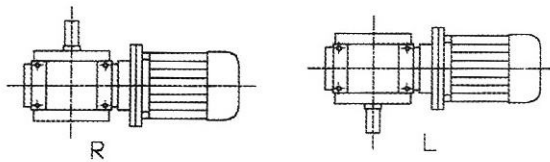

SHAFT DETAIL

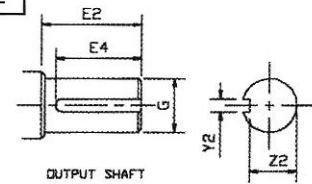

OUTPUT SHAFT

Size	A	B	C	D	H	H1	J	J1	K	L	M	N	P	Q	R	S	T
2"	2"	57	120	70	54	54	58	35	11	14	100	68	90	70	75	80	240
2.5"	2.5"	63	140	84	64	72	67	40	11	14	100	78	104	85	80	92	240
3"	3"	86	155	95	80	82	77	48	11	18	125	90	120	98	90	105	300
3.5"	3.5"	86	145	108	91	91	84	54	14	20	125	98	130	110	100	115	300
4"	4"	108	165	128	108	115	102	65	18	22	125	120	158	136	120	130	320
5"	5"	114	190	148	124	131	111	75	18	26	150	130	185	158	136	150	320
6"	6"	127	205	165	133	140	121	85	22	30	150	140	195	170	150	185	360

## SHAFT DIMENSIONS

Size	E2	E4	G	Y2	Z2
2"	54	50	23	6	20
2.5"	56	52	27	8	23
3"	68	63	33	10	29
3.5"	78	73	38	10	34
4"	90	85	45	12	40
5"	102	98	55	16	49
6"	110	105	60	16	54



# TYPE - NSM/O MOTORISED -OVERDRIVEN

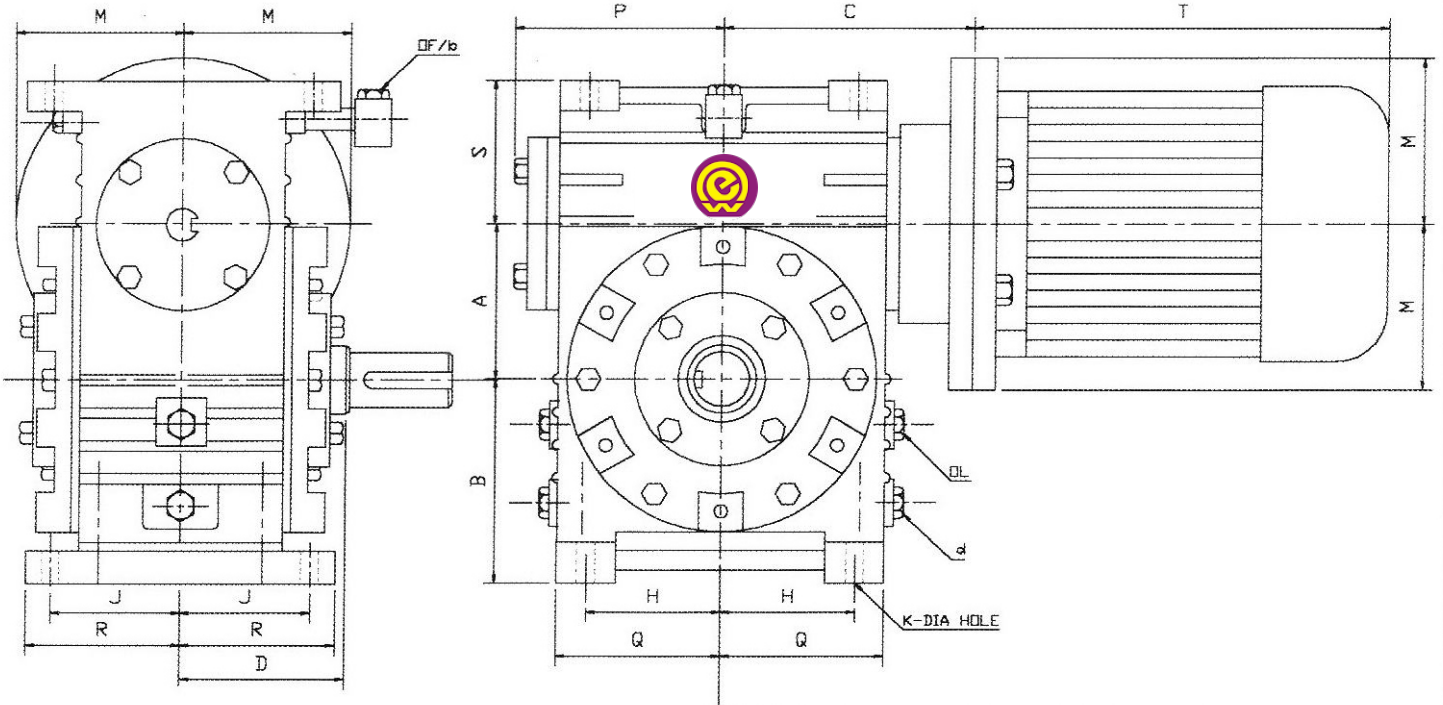

## SHAFT HANDLING

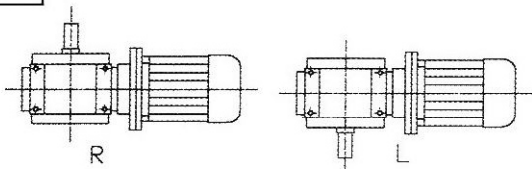

## SHAFT DETAIL

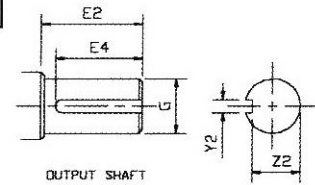

Size	A	B	C	D	H	J	K	L	M	P	Q	R	S	T
2"	2"	100	120	70	54	58	11	14	100	90	70	75	57	240
2.5"	2.5"	112	140	84	64	67	11	14	100	104	85	80	63	240
3"	3"	125	155	95	80	77	11	18	125	120	98	90	86	300
3.5"	3.5"	140	145	108	91	84	14	20	125	130	110	100	86	300
4"	4"	160	165	128	108	102	18	22	125	158	136	120	108	320
5"	5"	180	190	148	124	111	18	26	150	185	158	136	114	320
6"	6"	215	205	165	133	121	22	30	150	195	170	150	127	360

## SHAFT DIMENSIONS

E2	E4	G	Y2	Z2
54	50	23	6	20
56	52	27	8	23
68	63	33	10	29
78	73	38	10	34
90	85	45	12	40
102	98	55	16	49
110	105	60	16	54

# TYPE - NS/IVH MOTORISED INPUT VERTICAL

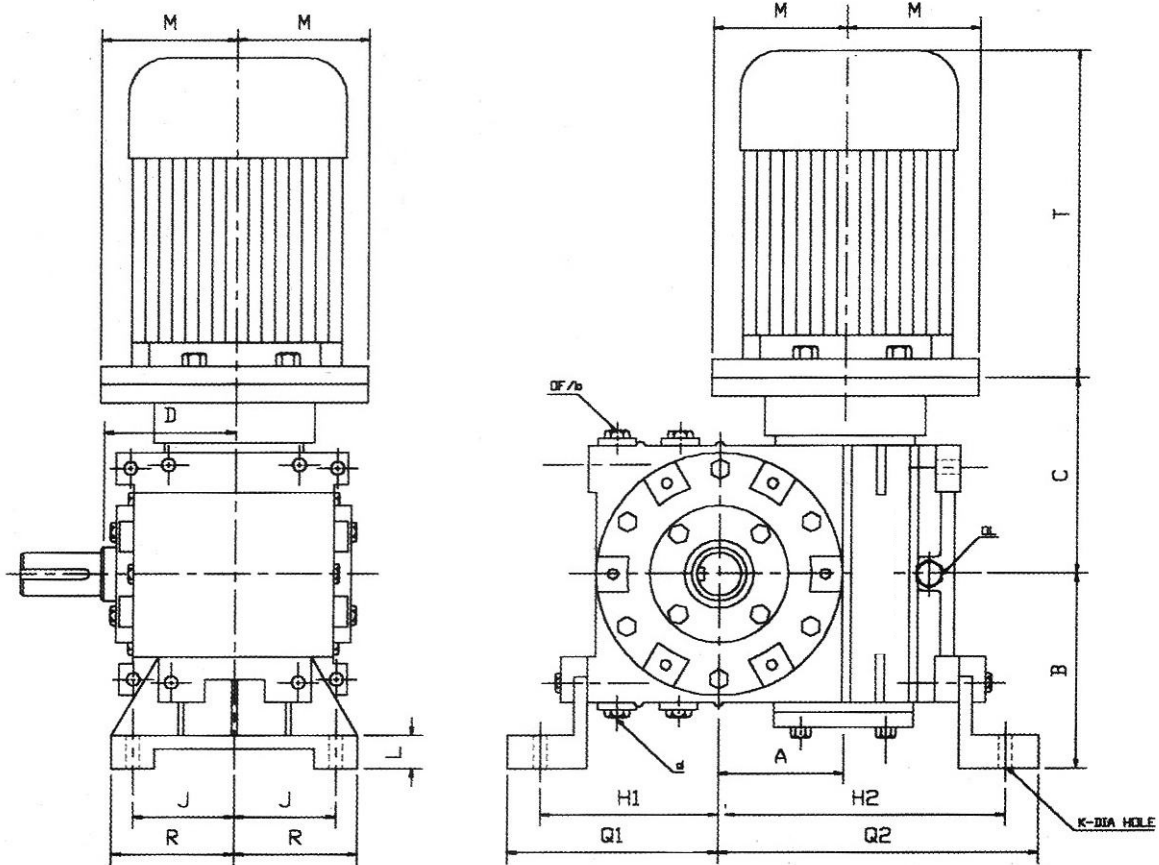

SHAFT HANDLING

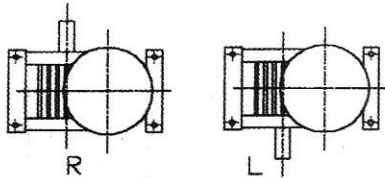

SHAFT DETAIL

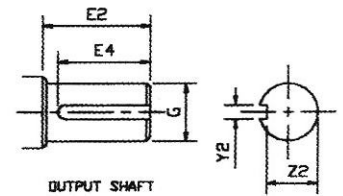

Size	A	B	C	D	H1	H2	J	K	L	M	Q1	Q2	R	T
2"	2"	102	120	70	105	133	58	11	14	100	120	148	75	240
2.5"	2.5"	120	140	84	117	151	67	11	14	100	132	166	80	240
3"	3"	142	155	95	135	192	77	11	18	125	157	214	90	300
3.5"	3.5"	150	145	108	143	205	84	14	20	125	162	227	100	300
4"	4"	180	165	128	160	240	102	18	22	125	182	262	120	320
5"	5"	195	190	148	182	272	111	18	26	150	205	295	136	320
6"	6"	210	205	165	218	308	121	22	30	150	240	330	150	360

SHAFT DIMENSIONS

E2	E4	G	Y2	Z2
54	50	23	6	20
56	52	27	8	23
68	63	33	10	29
78	73	38	10	34
90	85	45	12	40
102	98	55	16	49
110	105	60	16	54

# TYPE - NSM/IOH MOTORISED INPUT OUTPUT HOLLOW

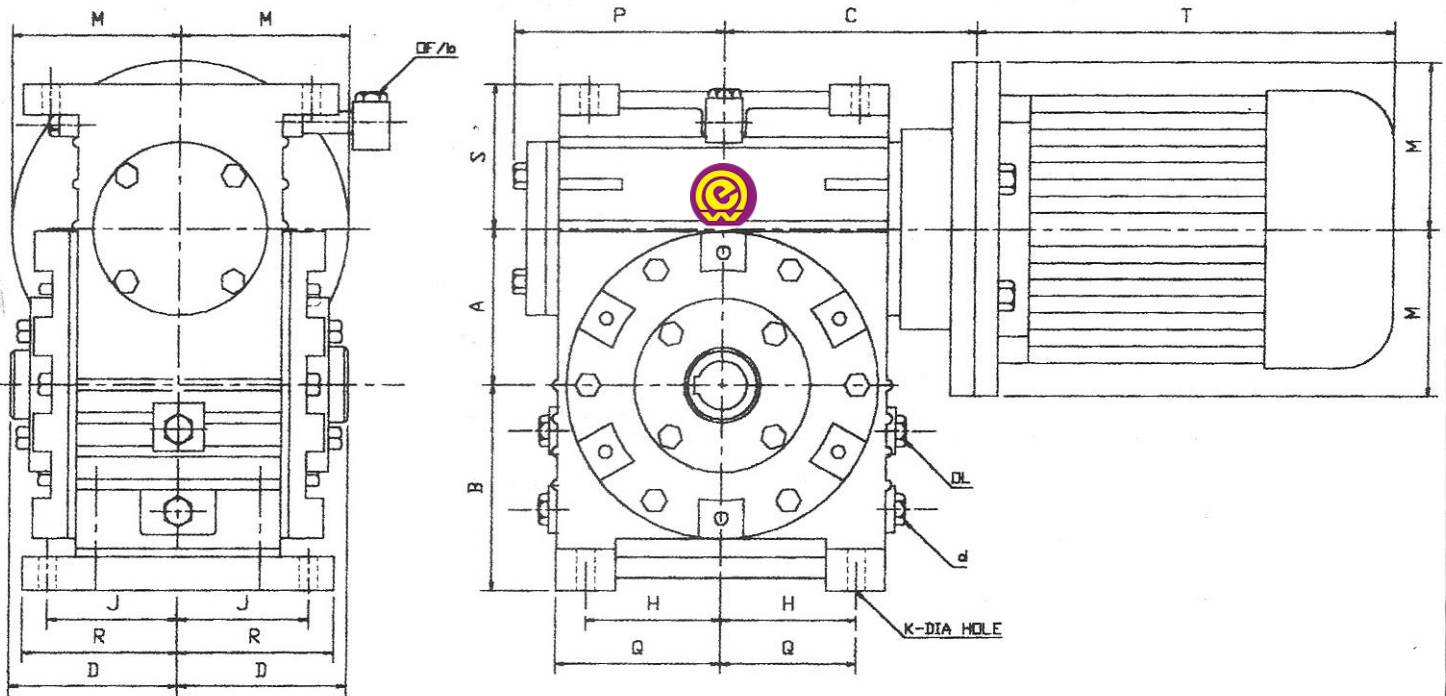

## MOUNTING DETAILS

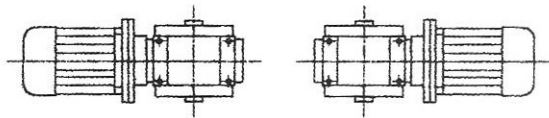

## HOLLOW SHAFT DETAIL

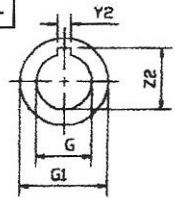

## HOLLOW SHAFT DIMENSIONS

Size	A	B	C	D	H	J	K	L	M	P	Q	R	S	T	G	G1	Y2	Z2
2"	2"	100	120	70	54	58	11	14	100	90	70	75	57	240	25	40	6	27.5
2.5"	2.5"	112	140	84	64	67	11	14	100	104	85	80	63	240	30	50	8	33.5
3"	3"	125	155	95	80	77	11	18	125	120	98	90	86	300	45	60	14	49
3.5"	3.5"	140	145	108	91	84	14	20	125	130	110	100	86	300	50	70	14	54
4"	4"	160	165	128	108	102	18	22	125	158	136	120	108	320	55	80	16	59.5
5"	5"	180	190	148	124	111	18	26	150	185	158	136	114	320	60	90	16	64.5
6"	6"	215	205	165	133	121	22	30	150	195	170	150	127	360	70	100	20	75



UAN: DL11A0007259

**OM ENGINEERING WORKS**

**Fabrication of All Crane Duty Gear Boxes**



[www.omengineeringwork.in](http://www.omengineeringwork.in)

**Authorised Dealer**