

UAN: DL11A0007259

**OM ENGINEERING WORKS**  
Fabrication of All Crane Duty Gear Boxes



[www.omengineeringwork.in](http://www.omengineeringwork.in)

# CRANE WHEELS catalog



**L BLOCK**





## crane wheels introduction

Crane wheels are replaced because of flange wear, flange breakage, and mechanical overloads characterized by pitting and spalling. Each of these in-service factors must be carefully considered before the combination of wheel design, material selection, hardness pattern and heat treating technology is selected.

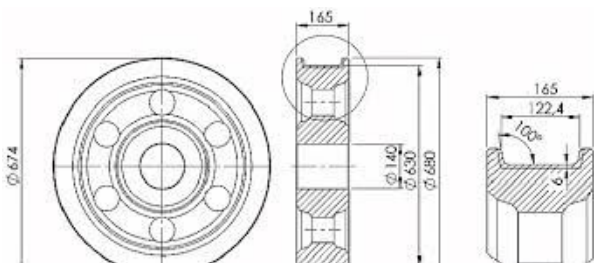

That's why every  hardened steel crane wheel is specially designed and heat treated to maximize its resistance to the damaging forces at work in heavy industrial applications.

### Crane Wheels are:

- Manufactured from fine grain, fully killed, vacuum degassed forged medium carbon steel
- Heat treated using our in house processes to provide a uniform contour hardness in the tread and inner flange wear surfaces, while maintaining a ductile core to resist shock loads
- Resistant to flange fracture or wear
- Designed to resist pitting and spalling

### Advantages of Degong forged Crane Wheels:

- Reduce maintenance cost of your wheels and wheel assemblies
- Improve the life of your rail
- Provide an additional 40% load carrying capability over rim toughened wheels
- Delivery in 6-8 weeks, less when required

### Applications:

- Overhead cranes
- Gantry and portal cranes
- Transfer cars



## Table of contents

**Part 0.** \* crane wheels introduction

**Part 1.** \* forged crane wheels

**Part 2.** \* sheaves

**Part 3.** \* crane wheel sets

**Part 4.** \* wheels processing

**Part 5.** \* shipment by container

**Part 6.** \* Applications



## Forged crane wheel



Forged Steel Crane Wheels are available in a wide range of standard sizes. In addition, crane wheels to meet your special design requirements can be produced in virtually any size, configuration and surface finish condition. We maintain a large inventory of carbon and alloy steels to meet your specific needs.



Forged Crane Wheels are available in any surface hardness up to HRC50 including our standard heat treatments.

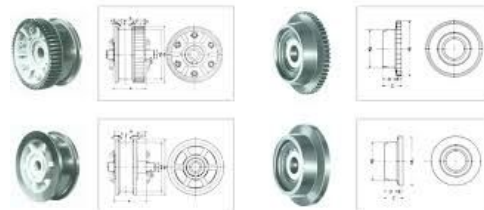



# Sheaves



A steel pulley sheave is coveted in industries where strict weight limits are in place, such as on boats. The reason for this unique benefit is because steel is much lighter than iron. However, a sheave pulley block forged from steel cannot handle as much weight and stress as an iron sheave.



Machine steel pulley sheaves are popular with industries that demand strong communication between workers. This stamped metal wheel provides a combination of strength and silence when it is in operation. This material makes it possible for silent operation when verbal commands are most important.



A pulley sheave has many specifications that can be customized for a particular job. Based on these factors, it can be used in a variety of industries. Users must consider how frequently the sheaves will be used, as well as what the weight load will be. Sheave height and width also are considerations that directly influence performance, because smaller wheels operate faster but usually cannot carry the same load. The pulling radius, cable diameter and maximum tension for the cable are other considerations that go into choosing the perfect sheave for a job.





## crane wheel sets

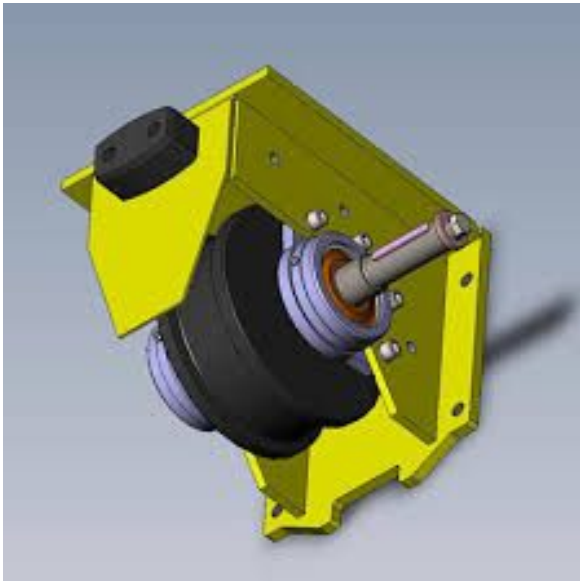

Crane wheels sets are available in different versions, either as a completewheelset or single wheel body available.

### Crane Wheel assembly

We hold industry knowledge to manufacture Crane Wheel Assembly. These are ideal to bear the load of the crane or hoist for balancing. We severely follow the necessary quality standards and use higher tools and technologies in the process of manufacturing these products. Our variety is widely appreciated for quality, durability, adequate casting and efficient consequences. The complete product variety can be availed by our customers at market leading price.

Our crane wheels meet the standard JB/T 6392.1-92.



**L BLOCK**







## wheels processing



Our forging press provides the power necessary to achieve the dramatic reduction ratios and material flow which are essential in high quality forgings. This closed-die design provides excellent strength-to-weight ratios necessary for your most critical forging needs. We stock a wide variety of carbon and alloy steels to meet your needs.



Wheel blanks that we manufacture are used in a wide range of heavy duty applications including locomotive traction drives, wind turbines, speed reducers, and mining machinery.

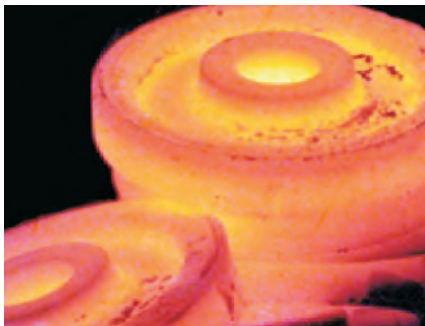

Once the die cavity is filled, the pressure is intensified to ensure the elimination of any microscopic porosity that may have existed as a result of the casting process. This provides an extremely uniform and homogeneous grain structure in the forging. This contrasts with cast wheels which will always have some porosity caused by shrinkage of the steel during solidification. The grain structure and directional orientation of flow lines produces greater yield and tensile strength and other physical properties than can be achieved in a cast wheel.



Heat treating can significantly enhance the mechanical properties of a forging by imparting specific hardness, strength, and wear characteristics to meet the requirements of the application. A wide variety of heat treating capabilities are at our disposal to meet virtually any application.





## Rough machining



To realize the rough machining of the outer and inner contour surface of wheel blank, and clean up the spare parts of the blank quickly.

## Quenching and tempering



Quenching and tempering is widely used as our heat treating capabilities. It is designed for maximum flexibility by allowing us to heat treat a wide variety of materials, diameters, thicknesses and bore sizes. We are now able to provide virtually any heat treatment for carbon and alloy steels. This quench and temper facility is most applicable to gear blanks, rollers and miscellaneous forgings in specialty applications.



## Fine cars



At raw materials receiving, steel ingots are inspected for proper identification. Certified test reports are required with each heat of steel. During cutting, heating and forging - each block is carefully monitored for identification of material grade and heat number.

We have a wide variety of analytic tools and testing equipment available. A metallurgical laboratory is maintained on premise to perform chemistry verification, tensile and yield tests, and grain size verification. We also have Level III technicians available to perform ultrasonic and magnetic particle testing. These people and equipment are able to make customer required N.D.T inspections that eliminate the possibility of any surface or sub-surface defects.

## Factory test



From raw material to final inspection and shipping, we maintain a thorough quality assurance program to meet the most demanding customer requirements. Before delivery wheels, we will provide material report, heat treatment report, dimension report and hardness test report.



## WORK FLOW:



1. Material Cutting



2. Drilling



3. Rough Turning



4. Quenching And Tempering



5. Finish Turning



6. Oiling



## Package and delivery





# CRANE WHEELS CATALOG





# Applications

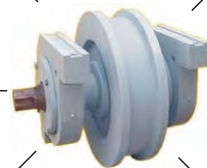
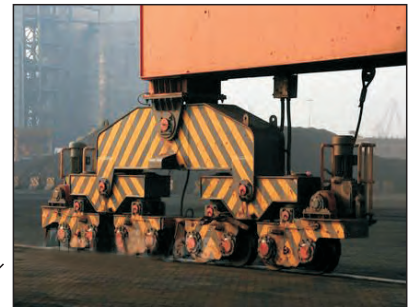



In addition to custom heavy-duty industrial wheels and wheel assemblies,  is also able to repair and recondition your existing wheel & axle sets.

Whether your assemblies require new axles, bearings, bearing housings or a complete overhaul, DGCRANE can get you back into production ASAP, often at a cost far less than buying new wheel assemblies, and they will be shipped back to you fully assembled, painted, lubricated and ready to install.

To keep our prices as low as possible on our crane wheels and forgings, we will continue to make investments in technology and equipment to constantly improve quality and drive down production costs.

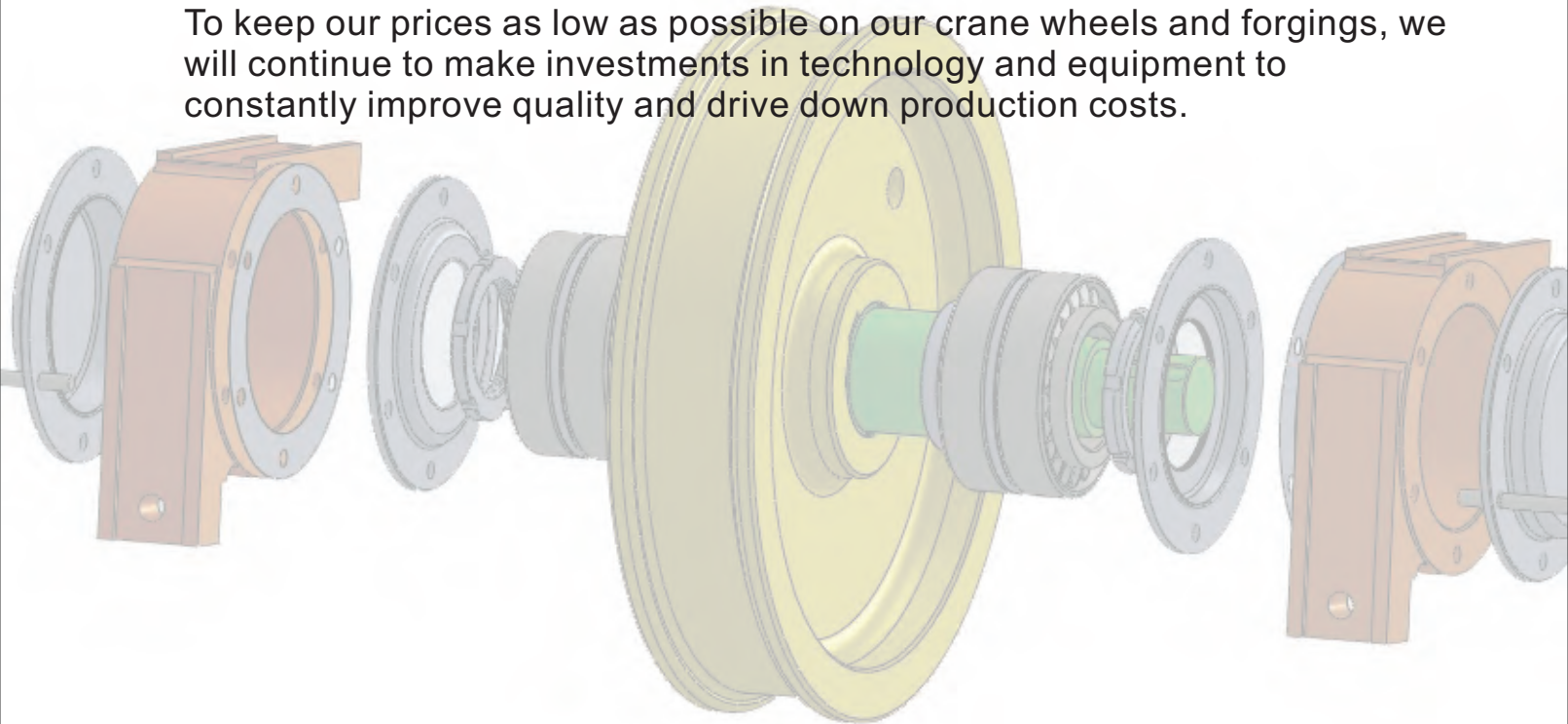

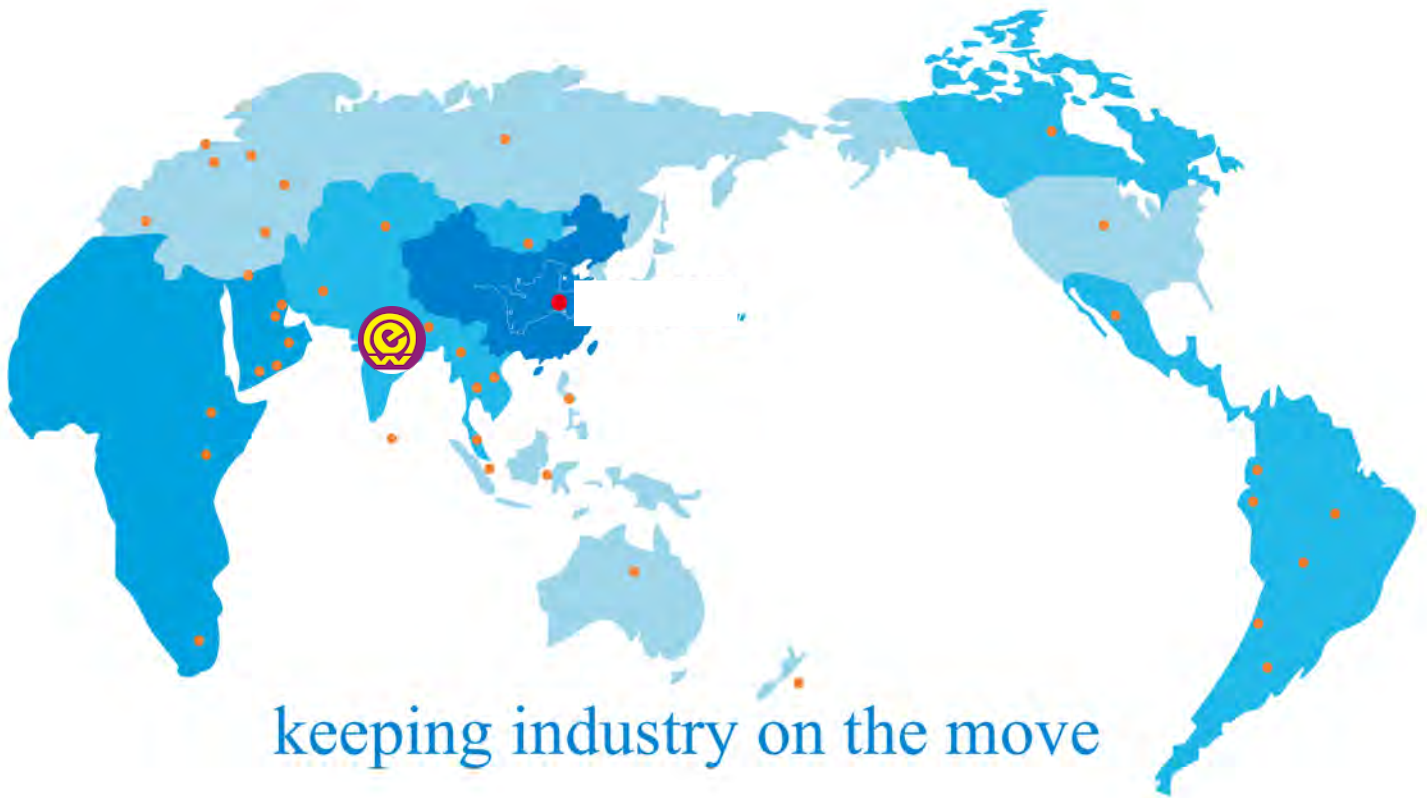

## Countries supplied to:

Singapore	uzbekistan	Africa	Ethiopia	Brazil
Thailand	bahrain	Egypt	Kenya	Ecuador
Vietnam	Georgia	Libya	Tanzania	Peru
Bangladesh	Iraq	Tunisia	Mauritius	holand
India	Syria	Nigeria	Mexico	germany
Pakistan	Turkey	Cameroon	America	Russia
Sri Lanka	The united Arab emirates	South Africa	Nicaragua	spain
kazakhstan	Qatar	In Zambia	Argentina	austrilia
tajikistan	Saudi Arabia	djibouti	boliviano	new zealand

**OM ENGINEERING WORKS**  
**E-14 MAYAPURI INDUSTRIAL AREA PHASE-2 NEW DELHI-110045, INDIA**  
**WEB-omengineeringworks.in,**  
**sales connect -veeromengineeringworks@gmail.com**  
**contact details- +91-9560885952,8860705952**